

## Distribution Annual Planning Report

2026-2030

04 May 2026



# Table of contents

Amendments	4
Disclaimer	4
<b>1. Overview</b>	<b>5</b>
<b>2. Purpose</b>	<b>6</b>
<b>3. AusNet's electricity distribution network</b>	<b>7</b>
3.1. Network location	7
3.2. High Voltage Sub-Transmission Network	8
3.3. Medium Voltage Distribution Network	9
3.4. Low Voltage Distribution Network	13
3.5. Communications Network	13
3.6. Distribution Asset Summary	14
3.7. Methodologies used in preparing the DAPR	15
3.8. Significant changes compared to previous year	24
<b>4. Forecasts for the forward planning period</b>	<b>26</b>
4.1. Demand forecasting methodology	26
4.2. Network Capacitive Current Forecasting Methodology	29
4.3. Network Capacitive Current Forecasts	29
4.4. Five-year forecasts	31
4.5. Future Assets	33
4.6. Forecasts of the DNSP performance against STPIS reliability targets	34
4.7. Factors that may have material impact on distribution network	35
<b>5. Network Asset Retirements and De-ratings</b>	<b>41</b>
5.1. Individual asset retirement and de-ratings	41
5.2. Grouped asset retirement and de-ratings	41

<b>6.</b>	<b>System Limitations for Sub-Transmission Lines and Zone Substations</b>	<b>42</b>
6.1.	Sub-transmission line import limitations	42
6.2.	Zone substations import limitations	48
6.3.	Transmission connection asset export limitations	48
6.4.	Sub-transmission line export limitations	49
6.5.	Zone substation export limitations	49
<b>7.</b>	<b>System Limitations for Primary Distribution Feeders</b>	<b>53</b>
7.1.	Primary distribution feeders import limitations	53
7.2.	Primary distribution feeder export limitations	58
<b>8.</b>	<b>Regulatory Investment Tests</b>	<b>72</b>
8.1.	RIT-D projects recently completed or in progress	72
8.2.	Future RIT-D projects	74
<b>9.</b>	<b>Completed, Committed and Planned Zone Substation and Feeder Developments</b>	<b>76</b>
9.1.	Bayswater Zone Substation rebuild	76
9.2.	Benalla Zone Substation rebuild and REFCL installation	76
9.3.	Clyde North Zone Substation Capacity Augmentation	77
9.4.	Kilmore South Zone Substation rebuild	77
9.5.	Maffra Zone Substation rebuild	77
9.6.	Newmerella Zone Substation rebuild	78
9.7.	Thomastown Zone Substation rebuild	78
9.8.	Traralgon Zone Substation rebuild	79
9.9.	Warragul Zone Substation rebuild	79
9.10.	Watsonia Zone Substation rebuild	80
9.11.	Wollert New Zone Substation	80
9.12.	Wonthaggi Zone Substation Upgrade	81
9.13.	Pakenham South New Zone Substation	81
9.14.	Further REFCL installation and geographic footprint	81
9.15.	Beveridge Zone Substation Development Project	83
9.16.	Construct a new 22kV distribution feeder at Cranbourne Zone Substation	84
<b>10.</b>	<b>Joint planning with the Transmission Network Service Provider</b>	<b>85</b>
<b>11.</b>	<b>Joint planning with other Distribution Network Service Providers</b>	<b>86</b>
11.1.	Distribution Network Service Providers' Joint Planning Process	86
11.2.	Jointly planned projects	86
<b>12.</b>	<b>Performance of AusNet Network</b>	<b>87</b>

12.1.	Reliability measures and standards in applicable regulatory instruments	87
12.2.	Performance against reliability measures and standards	89
12.3.	Corrective Actions – Reliability	93
12.4.	Quality of supply standards	93
12.5.	Performance against quality of supply measures and standards	97
12.6.	Corrective Action – Quality of Supply	99
12.7.	Processes to ensure compliance with the measures and standards	102
12.8.	Service Target Performance Incentive Scheme Information from the EDPR	104
<b>13.</b>	<b>Asset Management</b>	<b>106</b>
13.1.	Asset Management System	106
13.2.	Scope of the Asset Management System	106
13.3.	Asset Management Framework	106
13.4.	Asset Management Methodology	107
13.5.	Key Asset Management Strategies	108
13.6.	Distribution losses	110
13.7.	Further information on Asset Management	111
<b>14.</b>	<b>Demand Management Activities</b>	<b>112</b>
14.1.	Non-Network Solutions	112
14.2.	Key issues arising from applications to connect embedded generation	113
14.3.	Actions taken to promote non-network proposals	113
14.4.	Plans for non-network solutions over the forward planning period	115
14.5.	Embedded generation enquiries and applications	116
<b>15.</b>	<b>Information Technology and Communication Systems</b>	<b>117</b>
15.1.	Priorities and expenditure in the current regulatory period	117
15.2.	Proposed expenditure in the upcoming regulatory period	120
<b>16.</b>	<b>Regional Development Plan</b>	<b>122</b>
<b>17.</b>	<b>Advanced Metering Infrastructure Benefits</b>	<b>123</b>
17.1.	Utilisation of AMI data for life support customers	123
17.2.	Network planning and demand side response	123
17.3.	Network Reliability Initiatives	123
17.4.	Quality of Supply	124

# Amendments

Issue Number	Date	Description
0.0	30/12/2025	First issue
1.0	06/01/2026	Table 6 revised to ensure accuracy of reported values
2.0	04/05/2026	Section 6.4, Tables E1 and E2 are revised to ensure accuracy of reported values

## Disclaimer

This document belongs to AusNet Electricity Services Pty Ltd (AusNet) and may or may not contain all available information on the subject matter this document purports to address.

The information contained in this document is subject to review, and AusNet Services may amend this document at any time. Amendments will be indicated in the Amendment Table, but AusNet does not undertake to keep this document up to date.

To the maximum extent permitted by law, AusNet makes no representation or warranty (express or implied) as to the accuracy, reliability, or completeness of the information contained in this document, or its suitability for any intended purpose. AusNet Services (which, for the purposes of this disclaimer, includes all of its related bodies corporate, its officers, employees, contractors, agents and consultants, and those of its related bodies corporate) shall have no liability for any loss or damage (be it direct or indirect, including liability by reason of negligence or negligent misstatement) for any statements, opinions, information or matter (expressed or implied) arising out of, contained in, or derived from, or for any omissions from, the information in this document.

### Contact

This document is the responsibility of the Network Development & Planning, AusNet. Please contact the indicated owner of the document with any inquiries.

Manager Network Planning

Network Development & Planning

AusNet

Level 31, 2 Southbank Boulevard

Melbourne Victoria 3006

Ph: (03) 9695 6000

# 1. Overview

AusNet Electricity Services Pty Ltd (AusNet) is a regulated Victorian Distribution Network Service Provider (DNSP) covering eastern rural Victoria and the fringe of the northern and eastern Melbourne metropolitan area.

This Distribution Annual Planning Report (DAPR) has been prepared in accordance with clause 5.13.2(a)(2) of the National Electricity Rules (NER) and provides the information specified in the NER Schedule 5.8. This report also complies with clause 19.4 and Schedule 2 of the Victorian Electricity Distribution Code of Practice (ED CoP).

The DAPR provides information (among other things) on existing and forecast system limitations on our distribution network, and where and when they are expected to arise within the forward planning period from 2025/26 to 2029/30. The DAPR also denotes whether system limitations are subject to the Australian Energy Regulator's (AER) Regulatory Investment Test for Distribution (RIT-D). The DAPR complies with the requirements of clause 5.13.2 of the National Electricity Rules (NER). This report is published annually.

The DAPR includes a description of our network, asset management approach, planning and forecasting methods and forecasts, and a summary of demand management activities. It also provides information on the capacity of the network and system limitations for sub-transmission lines, zone substations and 22 kV feeders, along with the options being considered to address those limitations. Information on our planned asset replacement, retirement and de-rating works, along with our metering and information technology systems expenditure plans and our network performance and targets in the areas of power quality and reliability is also provided.

Information regarding planning for transmission to distribution connection points, required by clause 5.13 of the NER, is covered in the Transmission Connection Planning Report (TCPR)<sup>1</sup>.

Maps of AusNet network coupled with corresponding data are provided on our corporate website, in accordance with the requirements of schedule 5.8 (n) of NER: [AusNet - Rosetta Data Portal \(ausnetservices.com.au\)](https://ausnetservices.com.au)

These maps are updated annually and/or following major project completions to provide the latest available information on current and emerging feeder, zone substation and sub-transmission network limitations.

Any information provided using the system limitation template must be read in conjunction with this DAPR.

---

<sup>1</sup> A copy of the 2025 Transmission Connection Planning Report and Terminal Station Demand Forecasts can be viewed at AusNet website: [TRANSMISSION CONNECTION PLANNING REPORT \(ausnetservices.com.au\)](https://ausnetservices.com.au)

## 2. Purpose

This Distribution Annual Planning Report (DAPR) 2026-2030 is prepared by AusNet regarding its electricity distribution network and in accordance with the requirements of clause 5.13.2 of the National Electricity Rules (NER)<sup>2</sup> and clause 19.4 and Schedule 2 of the Victorian Electricity Distribution Code of Practice (EDCoP).

The purpose of this report is to describe AusNet distribution network, explain the approach to network planning, provide forecasts for the forward planning period, describe constraints on the network and detail plans to address these constraints.

---

<sup>2</sup> A copy of the National Electricity Rules can be found at the Australian Energy Market Commission's website:  
<http://www.aemc.gov.au/Electricity/National-Electricity-Rules/Current-Rules.html>

# 3. AusNet’s electricity distribution network

This section presents an overview of AusNet electricity distribution network, in accordance with the requirements of schedule 5.8(a) of the NER.

## 3.1. Network location

AusNet operates and manages an electricity distribution network serving the fringe of the northern and eastern Melbourne metropolitan area and the eastern half of rural Victoria (see Figure 1) delivering electricity to approximately 845,000 consumers.

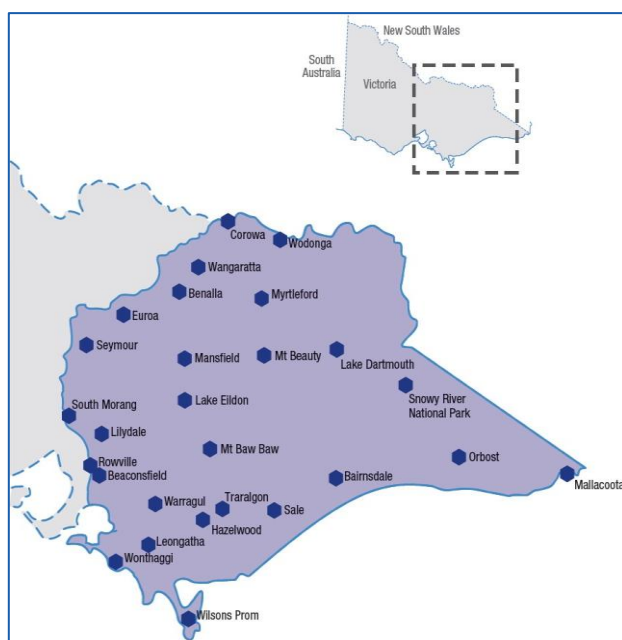

**Figure 1: AusNet Electricity Distribution Network**

AusNet distribution network is split into three regions, Central, East and North, as shown in Figure 2 below.

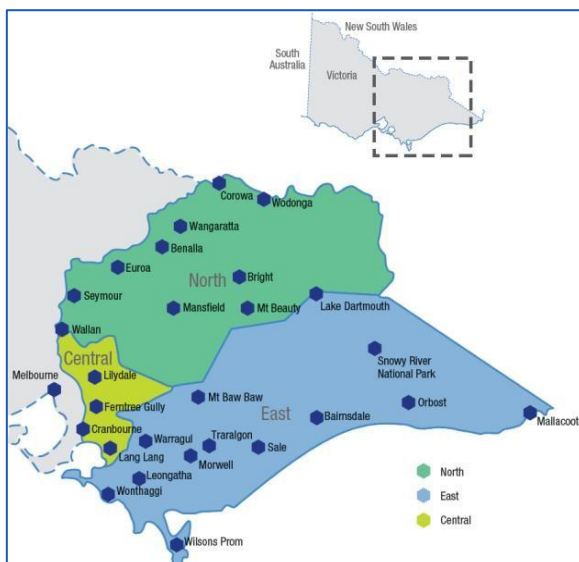

**Figure 2: AusNet Service Delivery Regions**

The distribution network is in a climate which is classified as temperate. The network area does not span across different classifications of climate.

The distribution network is located in areas where the average annual rainfall ranges from 600 mm to 1,200 mm. Some parts of the network in the Northern and Eastern regions are affected by flooding hazards. Approximately 35% of all network feeders have some parts in flood hazardous areas.

Approximately two-thirds of the distribution network is in areas designated as Bushfire Prone.

There are 364 distribution feeders, of which 14% are classified as Long Rural, 40% are classified as Short Rural and 46% are classified as Urban. A large proportion of feeders supply low density (lot sizes > 2000 m<sup>2</sup>) customer areas. Twenty-nine percent of distribution feeders have less than ten customers per kilometre of line length. Customers supplied in these areas amount to 16% of the total customers served by AusNet.

The electricity network comprises a 'sub-transmission' network that consists of predominantly overhead lines that operate at 66 kV, and a 'distribution' network, which generally operates at a voltage of 22 kV and consists mainly of overhead lines but also includes underground cables. Some customers in remote and low population density rural areas are supplied by Single Wire Earth Return (SWER) 12.7 kV distribution networks. Most customers are supplied at 230 V single phase or 400 V 3-phase by Low Voltage reticulation via distribution transformers.

## 3.2. High Voltage Sub-Transmission Network

The sub-transmission network is supplied at ten connection points from the Extra High Voltage (500 kV, 330 kV, 275 kV and 220 kV) transmission network that is owned and operated by AusNet Transmission Group Pty Ltd.

The sub-transmission network consists of overhead electricity lines operating at 66 kV, which are generally formed in loops fed from individual terminal stations. Although more interconnections have recently been established, these sub-transmission loops are generally not interconnected except under abnormal or emergency conditions. The loop configuration serves to maximise the reliability of the sub-transmission network by providing most zone substations with at least two sources of supply.

The length of each 66 kV sub-transmission loop depends on the proximity of the load centres to the terminal stations. The sub-transmission network has been developed over many years and therefore incorporates differing technologies, design standards, and plant and equipment types. As a result of these variations in the network, it has differing supply capacities. The capacity of each network loop is determined by numerous factors, including:

- Design working temperature
- Design of the particular network (which may impose loading or operational constraints)
- Thermal loading under outage conditions
- Voltage stability under outage conditions
- Conductor size and type

- Plant and equipment ratings.

Zone substations are generally supplied from more than one incoming 66 kV line, which are connected to the buses via circuit breakers. Within the zone substation, the incoming supply is transformed via one or several 66/22 kV transformers, ranging in size from 5 MVA to 33 MVA, and typically connected in parallel, unless separated to manage fault current levels to within regulatory and asset limits, or to manage rapid earth fault current limiter (REFCL) sensitivity required to meet REFCL compliance on total fire ban (TFB) days.

The 22 kV windings of the transformers are usually 'star' connected and earthed directly or via a Neutral Earthing Resistor (NER) or a REFCL to limit the phase-ground fault current. Most zone substation power transformers are equipped with on-load tap changing (OLTC) facilities to provide automatic control of the operating voltage. Additional reactive power support is provided by capacitor banks installed at most zone substations.

### 3.2.1. Protection

Protection of the sub-transmission system is achieved by a combination of current and voltage transformers, circuit breakers and protection devices arranged in schemes, which monitor the voltages and currents for abnormal conditions and initiate disconnection of supply in accordance with pre-established protocols. Protection schemes include:

- Distance
- Differential
- Over Current
- Earth Fault
- Residual Over Voltage/Neutral Displacement
- Under / Over Voltage and Under Frequency to initiate Load Shedding
- Generator run-back schemes

The protection applied to the sub-transmission network is duplicated and coordinated with that at the terminal stations, other zone substations and associated distribution network feeders. As per the existing industry practice, bare conductor overhead lines are fitted with automatic reclose facilities to minimise the impact of transient faults.

### 3.2.2. Earthing

Plant and equipment within the sub-transmission network employ local earthing whereby each piece of electrical equipment and conductive structure is directly connected to the general mass of earth via a dedicated earth connection. The 66 kV networks are referenced to earth via the connection transformers within the transmission network, which have their 66 kV winding star-points connected directly to the earthing grids of the respective terminal stations.

The sub-transmission network is an 'effectively' earthed system. In the event of a fault to earth on this network the earthing assets enable the flow of electricity to the general mass of earth, under such circumstances that step, touch and transfer voltages are managed, fire ignition is minimised, and electrical protection systems operate to limit network damage.

## 3.3. Medium Voltage Distribution Network

The 22 kV distribution network is currently supplied by fifty-eight zone substations, which are located near to the load centres. Additionally, three terminal stations supply 22 kV distribution feeders. Three 22/6.6 kV step-down substations supply the Mount Dandenong area via three 6.6 kV feeders. The Latrobe Valley power stations and mines are in part supplied via dedicated substations.

The Medium Voltage (MV) distribution network consists of 364 feeders as of 30 November 2025. These feeders predominantly operate at 22 kV, with three 6.6 kV feeders supplying the Mt. Dandenong area and a further five 6.6 kV and an 11 kV feeders supplying the coal fired power stations, associated mines, and support workshops within the Latrobe Valley. A total of approximately 468 customers are partly served by feeders from adjacent DNSPs, three United Energy feeders (DN4, NW13, RWT13) and two Essential Energy (EE) feeders (TRC01 and BOM8M3<sup>3</sup>).

<sup>3</sup> AusNet identifies EE's BOM8M3 feeder as BM8B31, BM8B32 and BM8B33 feeders.

Distribution feeders are generally operated in radial mode. In urban areas they can often be operated in open-loop arrangement via switches installed to provide alternative points of supply and thus improve the reliability of the network.

In rural areas, the average feeder length is 153 km (including spurs) with few alternative points of supply. This is the average of the combined MV overhead and underground line lengths from feeders classified as short and long rural in FY24 AER RIN. Distribution feeders are usually three-phase, but some spur lines, especially in rural areas, are single-phase supplied from two of the three available phases.

Remote and low population density rural areas are often supplied by Single Wire Earth Return (SWER) MV distribution networks. AusNet has over 530 SWER networks as of 30 November 2025. The SWER networks are supplied from two phases of the three-phase network via an isolating transformer, which provides the appropriate voltage transformation, regulation, and electrical isolation between the two networks. The SWER networks operate at 12.7 kV, with most overhead lines constructed using 3/2.75 mm steel conductor.

### 3.3.1. Distribution Substations

Distribution substations are located throughout the MV distribution network and provide transformation from the 22 kV reticulation to the customer's nominal service voltage (230/400 V or 230/460 V).

They range in capacity from 10 kVA to 2000 kVA and are classified into the following major types:

- Pole Mounted
- Ground Mounted Kiosk
- Indoor.

Distribution transformers on the three-phase network have a delta-star winding arrangement with a common voltage rating of 22 kV/433-250 V, while those on a single-phase network generally have a centre point earthed secondary winding and the voltage rating of 22 kV/250 V/500 V is common. Distribution transformers installed on the SWER circuits commonly have voltage ratings of 12.7 kV/250 V/500 V. The off-load voltage taps on each transformer can deliver the nominal voltage standard of 230 V/400 V and 230 V/460 V within +10%/-6% at the customers' point of connection.

### 3.3.2. Protection

Protection equipment, including protective relaying schemes, in conjunction with circuit breakers, automatic circuit reclosers, sectionalisers and fuses are applied to the distribution system to:

- Ensure safety of the general public and electricity workers by minimising any hazardous step, touch or transfer potential by isolating the faulted section of the plant within the protected zone.
- Ensure service continuity by sectionalising faulted elements of the network from unaffected portions of the network and therefore minimise disruption to most customers.
- Minimise equipment damage.

### 3.3.3. Earthing

Within zone substations the star-point of the 22 kV windings is connected to the station earth grid, directly or via a neutral earthing resistor, and thus to the general mass of earth.

Metallic MV equipment frames, switch handles, cable screens, conductive structures (e.g. concrete poles), surge diverters, exposed metal parts containing or supporting the MV conductors, and all interconnected metallic parts, are directly connected to a local MV earth and thus to the general mass of earth. These earthing systems are designed to:

- Ensure correct functioning of the protection systems.
- Limit over-voltages during fault conditions.
- Manage step, touch and transfer potential in high risk and well frequented areas.
- Co-ordinate transfer voltages with other authorities' assets in the vicinity.

### 3.3.4. Rapid Earth Fault Current Limiter (REFCL)

As of 1 November 2024, AusNet has installed Rapid Earth Fault Current Limiter (REFCL) technology at twenty-two of the twenty-two zone substations mandated by the Victorian Government in 2016.

The electrical protection technology is designed to minimise the fault current (energy) dissipated from phase to earth (wire to ground) faults on the 22 kV network to reduce the risk of fire ignition associated with network incidents.

Implementation and testing by government of two different types of REFCL technology was completed at Kilmore South zone substation on a limited 40 km section of network in 2014. Based on a sample period of network fault data, analysis undertaken by the Government and CSIRO predicts network fire related incidents associated with the nominated zone substations can be reduced by between 50-55%.

There are two types of REFCL technology available:

- The Ground Fault Neutraliser (GFN) which reduces single phase to earth fault currents on a network. The GFN does this by using resonant earthing with an enhanced 'residual current compensation feature' that injects current into an arc suppression coil (ASC) at 180° out of phase with the residual fault current. The GFN instantaneously eliminates the large fault current, reducing it to under 25 A and then close to 0 A within 3 cycles or 60ms. Its operation causes the phase voltage of the faulted phase to be reduced to near earth potential (zero volts), whilst the healthy phases rise by 173%, nominally from 12.7 kV to 22 kV. The implication of higher voltages on the healthy phases means that implementation of the REFCL technology can require significant asset replacement investment to ensure that all assets are rated for the higher phase voltages that they would be exposed to under fault conditions.
- The Advanced Residual Current Compensation (ARCC) which uses resonant earthing to reduce single phase to earth fault currents on a network

As the GFN has been available for implementation since the start of the REFCL implantation program, there are more GFNs deployed on AusNet distribution networks than ARCC's. ARCC have been implemented at Kinglake, Sale, Lang Lang, Kalkallo and Benalla.

REFCLs can be deployed in the zone substation or on individual 22kV feeders as a 'remote REFCL substation'.

### 3.3.5. Overhead Lines

There are approximately 422,171 poles supporting distribution and sub-transmission networks.

Most overhead lines utilise aluminium conductors, although copper was previously used and remains in service in some (generally older) areas. Steel conductors are predominantly utilised in rural (including SWER circuits) distribution areas.

The most common conductors used in the MV overhead network are Steel Conductor (SC) – 3/2.75, Aluminium conductor steel-reinforced (ACSR) – 3/4/2.5, 6/1/2.5, 6/1/3.0, 6/1/3.75, 6/1/4.75 and 6/4.75/ 7/1.60 and All Aluminium Conductor (AAC) – 7/2.5, 7/3.0, 19/3.25, 19/3.75, 37/3.75, 7/4.75 and 19/4.75.

The following methods are used for heavily vegetated areas:

- High Voltage Aerial Bundled Cable (HV ABC) is utilised for some 22 kV lines in environmentally sensitive treed areas, such as the Dandenong Ranges, to mitigate fire risk and minimise the incidence of tree and bark related faults. The main sizes of HV ABC used on the networks are 35 mm<sup>2</sup> and 185 mm<sup>2</sup> with aluminium conductors and non-metallic screens. A new type of HV ABC has been introduced to improve reliability. The new type is the Light Duty Metallic Screened HDME sheathed HVABC. This is generally known as LD MS HVABC and the standard conductor sizes are 35 mm<sup>2</sup> Al & 185 mm<sup>2</sup> Al. These cables can be used as the standard form of construction for both new overhead HV and for replacement of bare overhead HV in AusNet HV distribution network.

AusNet has also trialled and introduced:

- The Spacer Cable System as a standard MV cable system permitted for use on AusNet distribution network. The 22 kV Spacer Cable System consists of three covered conductors which are separated using a 'Spacer' and the whole system is supported by a tensioned catenary (messenger) wire. Spacers are generally placed every 10-12 metres along the span hung on the messenger wire. This system is suitable for heavy tree areas including where tree overhang is present (56Ms). The standard conductor sizes are 35 mm<sup>2</sup> Al, 50 mm<sup>2</sup> Al & 150 mm<sup>2</sup> Al.
- The Amokabel Open Wire Covered Conductor (OWCC) on standard MV cable system permitted for use on AusNet distribution network. The OWCC connection arrangement is like existing bare conductor and pole installation, however with different cross-arm mounts. The system is suitable for heavy tree areas including REFCL Network. The standard conductor sizes are 19/3.26mm (CCSX 159 AAAC), 1+6/3.37mm (CCSX 62 ACSR), and 7/2.12mm (CCSX 25 ACS SWER).

AusNet has also trialled and introduced:

- AusNet currently has deployed the EFD technology in Codified areas. The EFD devices detect partial discharges that occur from early signs of a fault and are time synced meaning that potential faults can be easily located. Data regarding the early signs of fault are communicated to AusNet via the device's inbuilt cellular data.

AusNet for the first time introduced a Hybrid Underground system during 2015. The hybrid system is a system which contains underground HV cables and where the existing substations, protection devices and low voltage network is left pole mounted and overhead. The hybrid system is an alternative supply arrangement in areas where the overhead medium voltage (22 kV, 11 kV or 6.6 kV) network is replaced with underground cable and where there is no space available to install kiosk substations. The standard conductor sizes are 35 mm<sup>2</sup> Al, 185 mm<sup>2</sup> Al, 240 mm<sup>2</sup> Al & 300 mm<sup>2</sup> Al and the cable types are standard underground cables.

### 3.3.6. Underground Lines

Approximately 2,625 km (route length) of medium voltage underground cables are utilised for distribution in new urban residential developments and where other limitation may apply such as visual impact and vegetation management. The MV underground cable network is categorised as greater than 1kV and up to 36kV. The 11 kV and 6.6 kV underground cables are primarily located in regional high bush fire risk areas (HBRA) and are also installed in the Latrobe Valley open cut mines. The 22 kV underground cables are generally located in road reserves in underground residential distribution (URD) housing estates. The cable insulation is mainly cross-linked polyethylene (XLPE). Paper Insulated Lead Covered (PILC) cables, although historically significant, are less commonly used today due to their environmental and practical limitations. The majority of underground residential distribution (URD) cables are 185 mm<sup>2</sup> or 240mm<sup>2</sup> aluminium conductor, three-core XLPE cables, whilst there are also some older paper-insulated three-core cables. The remaining 22 kV cable fleet facilitate connection to power transformers, capacitor banks, NER's and feeder exit cables that deliver the power either within or out from the zone substations.

### 3.3.7. Electric Line Construction (Codified) Areas

The Electricity Safety (Bushfire Mitigation) Regulations 2023 require any planned conductor replacement (1 kV to 22 kV) of four or more consecutive spans or any new medium voltage electric line to be constructed with insulated or covered conductor within codified areas.

The locations of medium voltage lines specified within the regulations are defined as those lines being within an "electric line construction area" (codified area). The codified areas within AusNet franchise area are illustrated in Figure 3 (red shaded areas). Further information may be found in AusNet "Bushfire Mitigation Plan – Electricity Distribution Network"

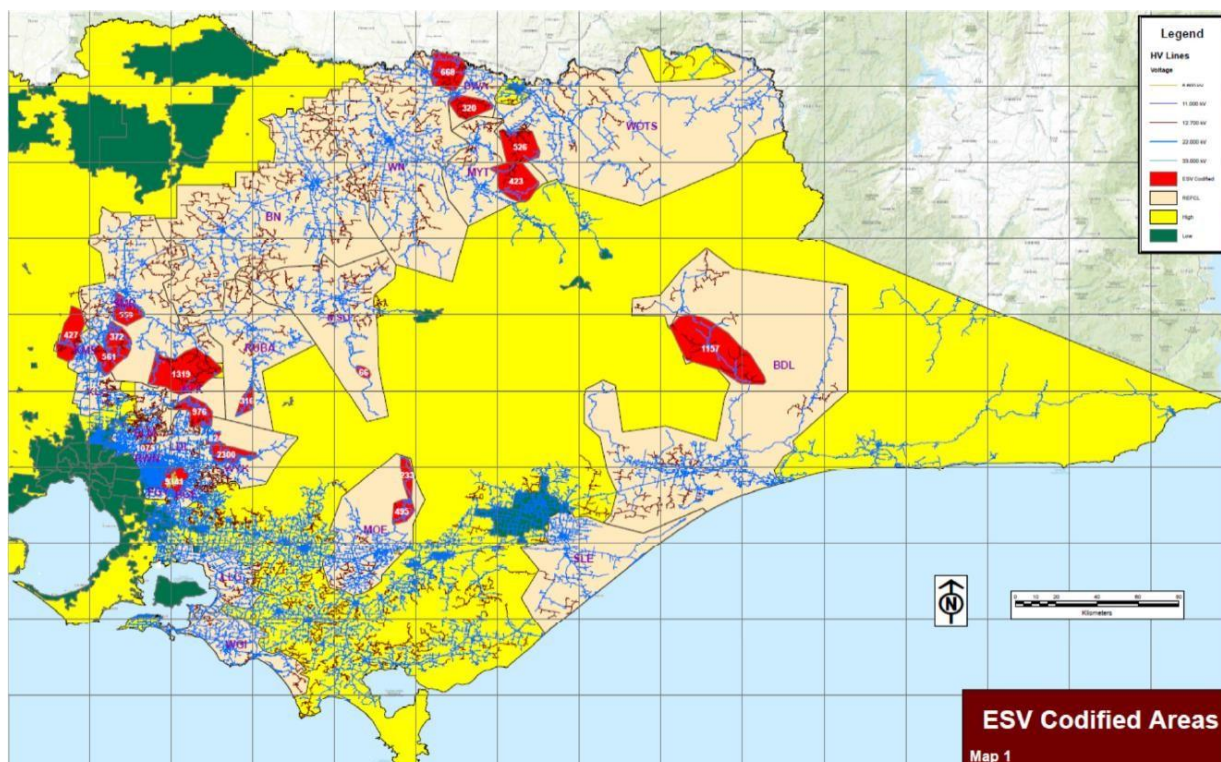

Figure 3 : Codified Areas within AusNet Distribution Network

## 3.4. Low Voltage Distribution Network

In urban and some rural locations reticulation at Low Voltage (LV) is utilised to supply small groups of customers. The LV lines are typically either three-phase (400 V) (line to line) or 230 V single phase (line to neutral) [with +10%/-6% voltage band] circuits with a neutral conductor. Insulated customer service cables are connected to these LV lines.

There is generally no permanent connection between adjacent LV circuits in urban areas although switching devices enable interconnections between some areas and load transfers in emergency conditions.

The LV overhead reticulation network consists of both open (bare) wire and insulated wire, Low Voltage Aerial Bundled Cable (LV ABC), construction.

**Bare Conductor** – Most of the LV bare conductors are of aluminium construction; although, some copper is in service in older areas. Typically, the standard conductor utilised for LV reticulation is 19/3.25 mm all aluminium conductor (AAC); although, there are other types and sizes of conductors still in service that were utilised on the LV network in the past.

**LV ABC** – LV ABC is cross linked polyethylene (XLPE) insulation over each of four aluminium cores. Typical conductor sizes are 95 mm<sup>2</sup> and 150 mm<sup>2</sup>.

**LV Cable** – LV underground cables are sized to suit the application but are generally 185 mm<sup>2</sup> and 240 mm with aluminium conductors and XLPE insulation.

### 3.4.1. Protection

The LV network protection is provided by fuses or in some cases moulded case circuit breakers installed on the LV side of the distribution transformers. The fuses are rated, and the circuit breaker tripping is set to suit the application, substation loading and coordination with MV fuses. Other considerations such as LV circuit lengths and fault current limits are also considered.

### 3.4.2. Earthing

The following types of earthing are applied within the LV distribution network:

- **Individual Multiple Earthed Neutral (IMEN)** – An earthing arrangement where the LV neutral conductor is permanently connected to earth at the substation supplying the system, all customers' premises and an auxiliary earth at the remote end of the LV reticulation Network.
- **Interconnected Multiple Earthed Neutral** – An earthing arrangement where the LV neutral conductor is permanently connected to earth at the multiple substations supplying the system, all customers' premises and at any point throughout the neutral system as required.
- **Common Multiple Earthed Neutral (CMEN)** – An earthing arrangement where all the MV and LV equipment is permanently connected to a common earth. The LV neutral conductor is connected to earth as per interconnected Multiple Earthed Networks and is used to bond other MV earthing points within the Network.
- **Direct Earth** – An earthing system where the customer's neutral conductor is directly connected to the Distribution Substation earth via underground cable sheath or dedicated overhead earth conductor.

### 3.4.3. Services

Connection from the customer point of supply to the LV distribution network is achieved via service cables. Service cables may be placed either overhead or underground. The aerial service cables are typically XLPE insulated<sup>2</sup> core or 4 core construction with aluminium conductors of 25 mm<sup>2</sup> and 35 mm<sup>2</sup> and, as required, 95 mm<sup>2</sup> and 150 mm<sup>2</sup> aerial bundled cables. The underground service cables are tapped from the underground LV reticulation cables using tee joints. Standard service cables are 16 mm<sup>2</sup>, 35 mm<sup>2</sup> and 50 mm<sup>2</sup> with copper conductors and XLPE insulation.

## 3.5. Communications Network

The communication network provides services for the following applications:

- Power system protection signalling.

- System Control and Data Acquisition (SCADA) for zone substations, Automatic Circuit Reclosers, and Sectionalisers.
- Operational Voice communications.
- Power Quality monitoring.
- Asset condition monitoring.
- Smart metering (Advanced Metering Infrastructure, AMI).

These services are provided by either the private AusNet communication network or third-party services. Third party services can be used for all applications except power system protection signalling because of the stringent technical requirements. Where there is no requirement for power system protection, the choice between the private AusNet network and third-party service is determined on lowest economic cost.

40 zone substations are connected to the optical fibre network. Eleven zone substations and about 2,300 pole top devices are connected by 4G/5G/satellite and 159 by private AusNet point-to-multipoint radio.

### 3.6.1. Communication Asset Types

Communication assets include telephone exchanges, network technologies, wireless access systems, and bearers. Network technologies include DIC systems (ethernet switches, routers, serial servers), Plesiochronous Digital Hierarchy (PDH), Synchronous Digital Hierarchy (SDH), and Wave Division Multiplexers (WDM), and Multiprotocol Label Switching (MPLS). Wireless access systems include the private point to multipoint radio and remote modems connecting field devices to third party mobile systems. Bearers cover point-to-point microwave radios and optical fibre cables. There are two types of optical fibre assets installed on distribution poles to support the communications network, All Dielectric Self Supporting (ADSS) and Optical Ground Wire (OPGW).

## 3.6. Distribution Asset Summary

Table 1 lists common asset types, sub-types, and quantities.

**Table 1: Number and types of assets**

#	Asset Type	Description	Number
1	Connection Points	Terminal Stations (66kV Connection Point)	10
2	Connection Points	Terminal Stations (22kV Connection Point)	2
3	Connection Points	Zone Substations (66/22kV)	58
4	Connection Points	Substations (22/6.6kV)	3
5	Connection Points	Zone Substations (Single Customer)	9
6	Connection Points	Switching Station	1
7	Transformers	Zone Substations Transformers <sup>4</sup>	144
8	Transformers	Distribution Transformers (Pole Mounted) <sup>6</sup>	57,725
9	Transformers	Distribution Transformers (Kiosk, Ground Outdoor or Indoor Chamber Mounted) <sup>6</sup>	5,644
10	Circuit Breakers	High Voltage (>22kV) <sup>7</sup>	186
*11	Circuit Breakers	Medium Voltage (≤22kV) <sup>7</sup>	978
*11	Circuit Breakers (Fuse Savers)	Medium Voltage (≤22kV) <sup>7</sup>	1997
12	Feeders	Number of 22kV feeders	364

13	Feeders	Number of 11kV feeders	1
14	Feeders	Number of 6.6kV feeders	8
15	Conductors	Overhead (Low Voltage <1kV) (km) <sup>6</sup>	6,565
16	Conductors	Overhead (SWER) (km) <sup>6</sup>	6,421
17	Conductors	Overhead (Medium Voltage 11 and 22kV) (km) <sup>6</sup>	22,537
18	Conductors	Overhead (High Voltage 66kV) (km) <sup>6</sup>	2,478
19	Conductors	Underground (Low Voltage <1kV) (km) <sup>6</sup>	5,838
20	Conductors	Underground (Medium Voltage 11 and 22kV) (km) <sup>6</sup>	2,764
21	Conductors	Underground (High Voltage 66kV) (km) <sup>6</sup>	16
22	Conductors	Service Lines (number of services) <sup>6</sup>	197,952
23	Poles	Wood Poles <sup>6</sup>	179,952
24	Poles	Concrete Poles <sup>6</sup>	133,011
25	Poles	Steel Poles (excluding public lighting poles) <sup>6</sup>	411
26	Poles	Public Lighting Poles <sup>6</sup>	111,448
27	Poles	Crossarms <sup>6</sup>	405,400
28	Communications	Optical fibre Cable (OPGW, ADSS, Underground) Routes	678
29	Communications	Radio systems (Point to point and Point to Multipoint)	86
30	Communications	Network Technologies (DIC [Routers, Switches and Serial servers], PDH, SDH, WDM and TPS)	323
31	Communications	Telephone exchanges	7
32	Communications	Point to point radio links – AMI	0
33	Communications	Access Points - AMI	689
34	Communications	Relays - AMI	838
35	Communications	Microaps - AMI	4600

## 3.7. Methodologies used in preparing the DAPR

The DAPR covers a five-year forward planning period. The annual planning process commences after the extended summer season ending 31 March each year. The demand forecasts for connections points, zone substations, sub-transmission lines and distribution feeders are developed using the method described in Section 4.1, and network limitations are identified using the Probabilistic Planning Philosophy.

### 3.7.1. Planning Process

The planning activities are discussed in this section of the report and consist of the following steps:

- Review the long-term strategy for the distribution system with due consideration of network reliability, network resilience, network capacity, quality of supply, network safety, environmental requirements, and asset management and regulatory strategies.

- Forecast the maximum and minimum load demand for the next fifteen-year period.
- Forecast the network capacitive current for the next fifteen-year period.
- Confirm the capability of the existing network.
- Identify network constraints or network performance issues.
- Formulate options to resolve network constraints or needs.
- Seek non-network options including demand-side options. Publish a non-network options report under RIT-D or RIT-T requirements where appropriate.
- Study these options to ensure compliance with technical limits, planning philosophies, regulatory criteria and guidelines, reliability and quality of supply standards and asset management strategies.
- Develop cost estimates for each option as well as cost savings and benefits of each option and establish the most cost-effective alternative that meets the technical and other requirements.
- Investigate the economic viability of the most cost-effective option by comparing the economic cost of the probability weighted energy at risk due to the contingency, reliability, or performance gap with the cost of reducing this risk or improving the network performance.
- Prepare a planning report documenting all considerations and recommendations.
- Prioritise the different distribution projects based on the company's business strategy and funding guidelines.
- Obtain approval of the recommended plans, document plans and initiate execution of the projects in the plan.
- Publish draft and final project assessment reports under RIT-D requirements as appropriate.

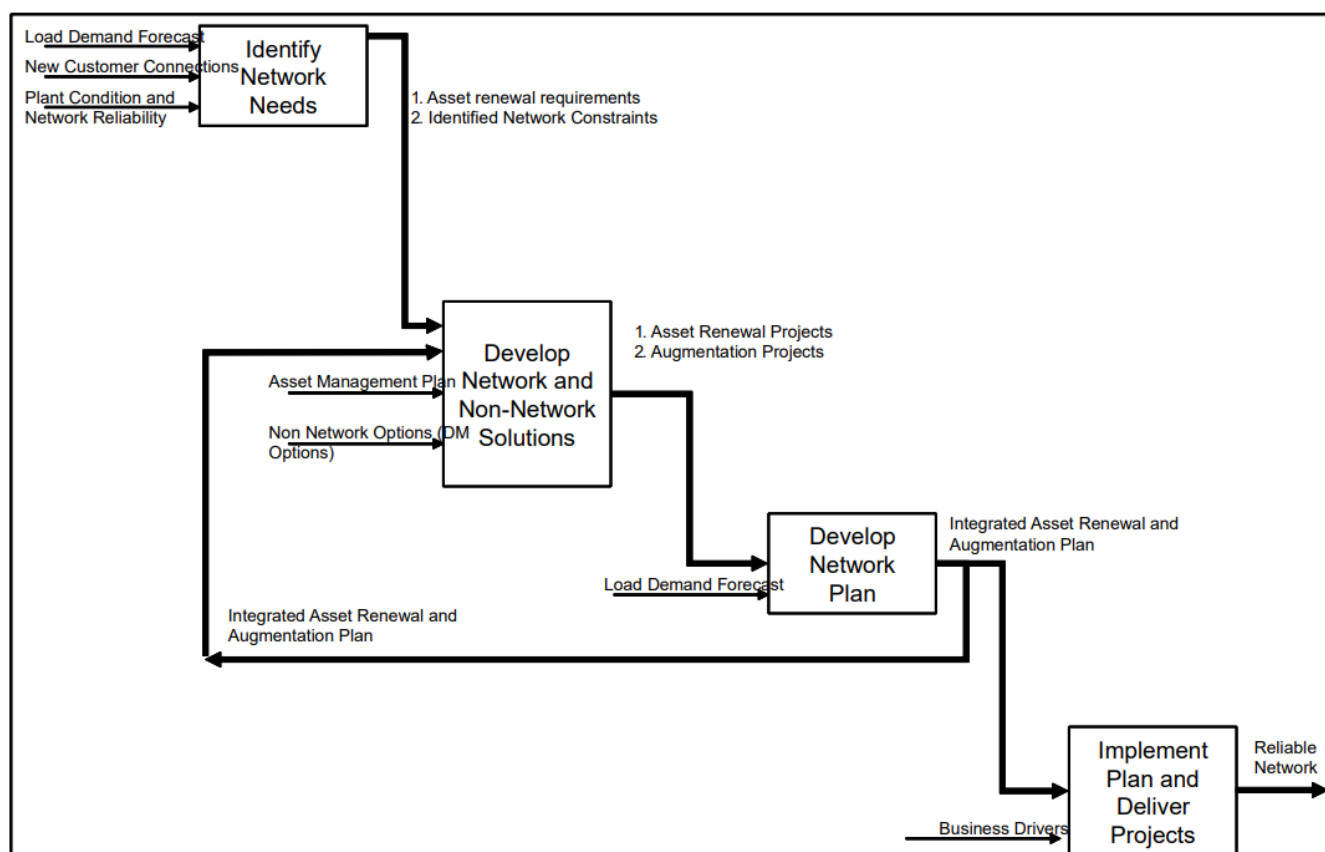

**Figure 4: Distribution Network Planning Process**

### 3.7.2. Identification of network needs or constraints

Network augmentation is essentially required to provide additional power transfer capacity to meet increasing customer load or generation levels or, in the case of rapid earth fault current limiter (REFCL) protected zone substation, additional capacity to meet network capacitive current growth. Asset retirement and, where

economically justified, replacement is required when the deteriorated condition of existing assets poses a service level risk, driven by reliability, safety, network security, environmental and plant damage risks, that outweighs the cost of retirement and/or replacement. The need for network augmentations or asset retirement and replacement is generally driven by the following factors:

- Increased load demand at existing supply points.
- New loads connecting to the distribution network.
- New network, resulting in capacitive current growth, to supply new connections.
- New generation connections or increased generation at existing connection points.
- Meeting quality of supply requirements.
- Improving the reliability of the network in response to the regulatory incentive scheme.
- High network losses supporting the justification for network augmentation based on reduced energy and demand losses as well as environmental benefits.
- Environmental requirements.
- Deteriorating condition of ageing assets.
- Risk mitigation.

Increased penetration of Customer Energy Resources (CER) have resulted in significant reverse power flow and light load conditions in some parts of the network and triggered augmentation of the low voltage network to manage these reverse flows and voltage levels. In response to the reduction in minimum demand and changes in the load shape driven by increased penetration of CER, AusNet has developed a 'minimum demand' forecast for this DAPR to better communicate this new phenomenon.

### 3.7.3. Overall objective of network planning

The planning standards and criteria applied in network development are a significant determinant of network related costs. Costs associated with distribution connection facilities can be considered to comprise of two parts:

- The direct cost of the service (as reflected in network use of system charges and the costs of losses).
- Indirect costs borne by customers as a consequence of supply interruptions caused by network faults.

In developing and applying their planning standards and investment criteria, AusNet aims to develop network facilities in an efficient manner that minimises the total (direct plus indirect) life-cycle cost of network service borne by customers.

This basic concept is illustrated in Figure 5 below.

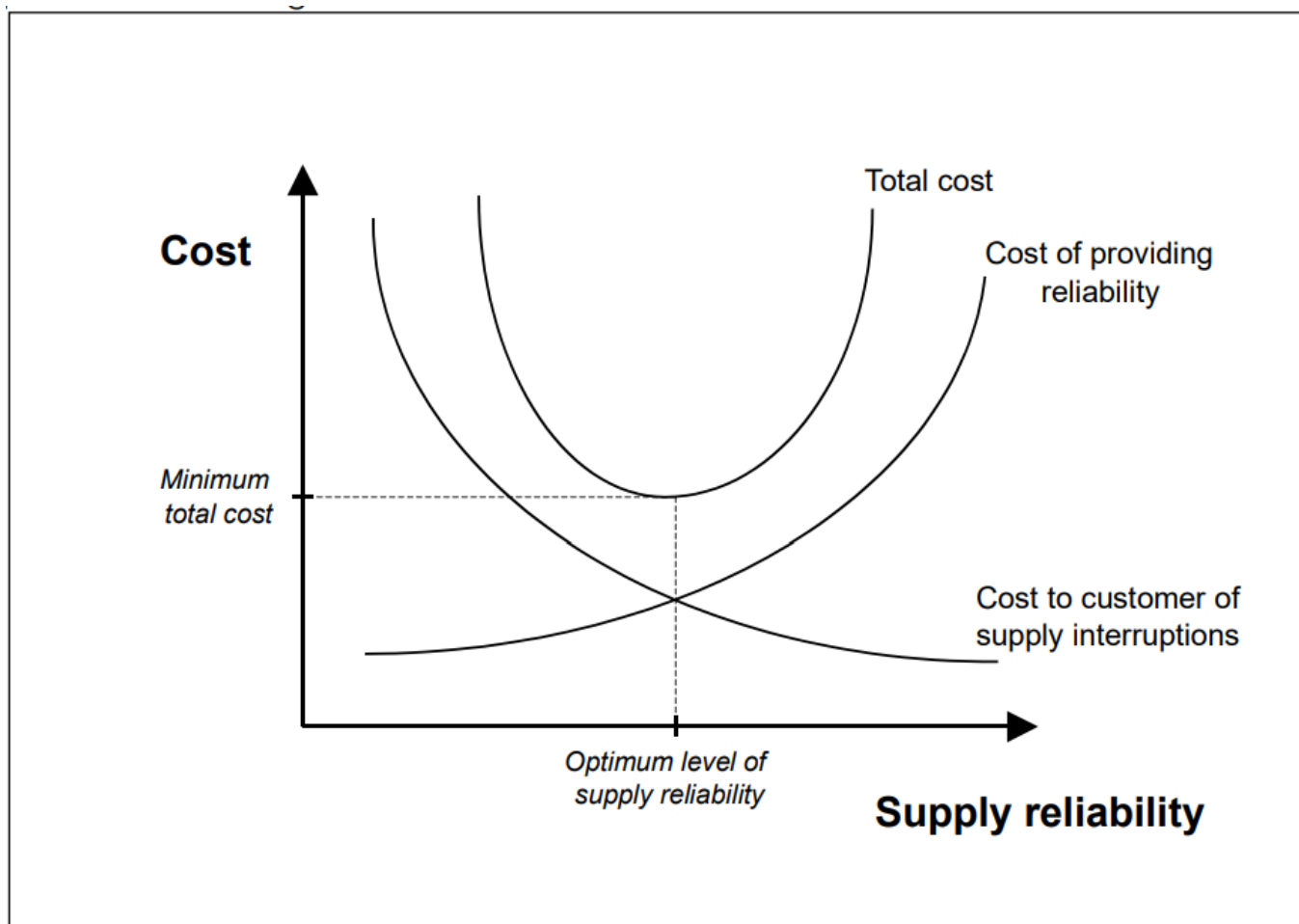

**Figure 5: Balancing the direct cost of service and the indirect cost of service level risks including supply interruption**

Additionally, AusNet distribution connection investment decisions aim to maximise the net present value to customers, having regard to the costs and benefits of non-network alternatives to augmentation. Such alternatives include, but are not limited to, demand-side management and embedded generation.

### 3.7.4. Overall approach to distribution planning and investment evaluation

AusNet uses a probabilistic approach to network planning. Under probabilistic planning, the deterministic N-1 criterion applied in some networks is relaxed and simulation studies are undertaken to assess the amount of energy that would not be supplied (or curtailed) if an element, or elements, of the network were out of service. The application of this approach often leads to the deferral of augmentation that would otherwise proceed under a deterministic standard. Under a probabilistic network planning approach, conditions often exist where some of the load cannot be supplied (or some of the generation requires curtailment) with a network element out of service (hence the N-1 criterion is not met); however, the value of the energy not supplied is insufficient to justify additional investment, considering the probability of a forced outage of a particular network element.

The transmission connection assets for which the DNSPs have planning responsibility form part of the Victorian electricity transmission network. Given that the Australian Energy Market Operator (AEMO) applies a probabilistic network planning approach to the development of the shared transmission network, the Victorian DNSPs consider it appropriate to adopt a similar approach in distribution network planning and investment decision analysis. AusNet considers it is appropriate to plan the distribution network (i.e. zone substations and sub-transmission lines) in a manner consistent with the planning for the 'upstream' network and connection points. Implicit in the use of a probabilistic approach is acceptance of the risk that there may be circumstances (such as the loss of a transformer during a high demand period) when the available zone substation or 66 kV loop capacity will be insufficient to meet actual demand and significant load shedding could be required.

### 3.7.5. Valuing supply reliability

To determine the economically optimal level and configuration of network capacity to service maximum demand, and hence the supply reliability that will be delivered to customers, it is necessary to place a value on supply reliability from the customer's perspective. This is referred to as the value of customer reliability (VCR).

The VCR represents, in dollar terms, the estimated aggregated value that customers place on the reliable supply of electricity. This value varies by customer type and outage characteristics and therefore varies at different locations within in the network based on the mix of customer types at that point. As customers cannot directly specify the value they place on reliability, the VCR plays an important role in determining the efficient level of investment in electricity services required by customers.

Location-specific VCRs are calculated for each asset using the customer consumption profile and sector-specific AER VCR values.

The sector VCR values used were:

Residential – \$49.23/kWh

Commercial – \$34.39/kWh,

Industrial – \$33.49/kWh

Agricultural – \$22.25/kWh

By weighting each sector's VCR according to its share of total consumption, the resulting locational VCR reflects the actual energy usage mix, and willingness to pay across all customer segments.

### 3.7.6. Valuing curtailed generation

To determine the economically optimal level and configuration of distribution capacity that would be provided to embedded generators for the export of power into the network, it is necessary to place a value on energy curtailed from embedded generators at times when the export capacity is breached.

On 12 August 2021, the AEMC made a final determination on its "Access, pricing and incentive arrangements for distributed energy resources" Rule change<sup>4</sup>. Under the Rule change, the AER is required to develop customer export curtailment values ("CECV"), which are an estimate of the detriment to customers and the market of export curtailment due to network limitations (in \$ per kWh of exports curtailed). CECVs are expected to play a similar role to the VCR in evaluating the net benefit of reducing or removing network constraints. For instance, it is expected that the CECVs will be used to assess whether proposed steps to reduce export curtailment (such as increasing CER hosting capacity) can be economically justified.

In June 2022, the AER published its Customer Export Curtailment Value Methodology. At the same time, the AER also published a DER Integration Expenditure Guidance Note<sup>5</sup>, which includes direction on how distribution network service providers should i) develop business cases for network investment integrating higher levels of customer DER and quantify DER values, ii) develop DER integration plans and investment proposals, and iii) quantify DER benefits in a cost-benefit analysis. Updates occur every financial year, with adjustments for inflation and revised inputs such as emissions intensity profiles and demand assumptions.

### 3.7.7. Application of the probabilistic approach to network planning

The probabilistic planning approach involves estimating the probability of various network conditions coinciding, such as plant outages coinciding with peak import or export conditions, and weighting the service level costs of such events by their probability of occurrence to assess:

<sup>4</sup> AEMC, Rule Determination, National Electricity Amendment (Access, Pricing and Incentive Arrangements for Distributed Energy Resources) Rule 2021, 12 August 2021.

<sup>5</sup> <https://www.aer.gov.au/networks-pipelines/guidelines-schemes-models-reviews/assessing-distributed-energy-resources><https://www.aer.gov.au/networks-pipelines/guidelines-schemes-models-reviews/assessing-distributed-energy-resources-integration-expenditure-guidance-note/final-decision>

- The energy at risk of load not being supplied (or generation being curtailed) if no risk mitigation action is undertaken; and
- Whether it is economic to invest in risk mitigation action to reduce the forecast service level risk.

The quantity and value of energy at risk is a critical parameter in assessing a prospective risk mitigation investment. Probabilistic planning aims to ensure that an economic balance is struck between the cost of:

- Providing supply redundancy and increased levels of safety to manage service level risk; and
- Exposure to the conditions (plant outages or network loading levels) that result in the identified supply level risk being realised.

In other words, recognising that plant outages and very extreme loading conditions (either import or export) may occur for a small fraction of the year, it may be uneconomic to retire and replace poor condition plant or provide additional capacity to cover the possibility of a network outage under extreme conditions. Rather, the probabilistic approach indicates that service level risk mitigation action should take place only when the service level risk has increased to the extent that the value of expected unserved energy and risk exceeds the investment cost to reduce the level of expected unserved energy and risk.

This approach provides a sound estimate of the expected net present value to consumers of distribution system augmentation, retirement or replacement. However, implicit in its use is acceptance of the risk that there may be circumstances when the available distribution network will be insufficient to meet actual demand for distribution services. The extent to which investment should be committed to mitigate that risk is a balance between engineering and economic analysis; having regard for:

- The results of probabilistic and deterministic studies of possible outcomes, and the inherent uncertainty of those outcomes.
- Regulatory and other legal compliance obligations.
- The potential costs and other impacts that may be associated with very low probability events, such as single or coincident transformer outages at times of peak demand, and catastrophic plant failure leading to extended periods of plant unavailability.
- The availability and technical feasibility of cost-effective contingency plans and other arrangements for management and mitigation of risk.

The Victorian DNSPs' obligation (under clause 13.3 of the Victorian EDCoP) to use best endeavours to meet, among other things, reasonable customer expectations of reliability of supply.

### 3.7.8. Methodology for assessing supply risk at zone substations

The methodology for assessing supply risk at zone substations includes assessing the magnitude, probability and impact of loss of load (or curtailment of generation) at each zone substation.

The following key data are calculated for each zone substation:

- Hours at risk: For a given maximum (or minimum) demand forecast, this is the number of hours per annum that a zone substation operates beyond its firm import (or export) rating.
- Load at risk (or generation at risk): For a given maximum (or minimum) demand forecast, this is the maximum amount of load (or generation) that would be shed should an asset failure within the zone substation occur, due to an asset outage occurring coincident with operation of the zone substation beyond its N-1 import (or export) rating.
- Energy at risk: This is the amount of energy, weighted by the demand conditions considered (10% POE and 50% POE), that would not be able to be imported or exported from a zone substation, assuming an outage of a transformer, circuit breaker or other critical asset occurs at that station in that particular year. This measure provides an indication of the magnitude of energy that would not be supplied to the load during import (or the amount of generation curtailment needed during export) in the unlikely event of a major network asset outage.
- Expected unserved energy: This is the energy at risk weighted by the probability of potential network asset outages and their repair times. This measure provides an indication of the amount of energy, on average, that will not be imported (or exported) in a year, considering the low probability that a transformer, circuit breaker or other critical asset at the zone substation fails and is out of service.

Supply risk assessments for each zone substation provide estimates of energy at risk and expected unserved energy based on the demand forecasts.

### 3.7.9. Interpreting import and export limitations

Customer loads cause power to flow in the forward direction (i.e., towards the customer), and this is referred to in this DAPR as import. However, when sufficient numbers of embedded generating units are operating in aggregate, they may cause power to flow in the reverse direction (i.e., towards the transmission system) through various points within the upstream high-voltage distribution network. This is referred to in this DAPR as export.

An import limitation occurs when the maximum demand goes beyond the network asset's import rating (denoted as a positive number). Conversely, an export limitation occurs when the minimum demand is negative and goes beyond the network asset's export rating (denoted as a negative number).

The import ratings that are used for identifying network limitations under maximum demand conditions are mainly thermally limited, and generally higher in magnitude than the export ratings used for minimum demand conditions which are mainly voltage-limited. This is due to the limited capability of transformer buck-taps and On-Load Tap Changer (OLTC) mechanisms, and the magnitude of voltage rises occurring within the distribution network associated with reverse power flows.

The method adopted for assigning export ratings selects the smaller of the:

- Power flow limitation, being the same as the import rating (which may be determined by thermal capacity, protection or voltage drop considerations), except for some specific transformer OLTCs that can introduce up to a 70% reduction factor under reverse power flows;
- Voltage rise limitation being the largest reverse power flow that still maintains:
- Voltage rises within acceptable limits, while considering the voltage drops at maximum forward power flow, to maintain regulatory compliance for the steady-state voltage limits at customers' points of supply to the network; and
- Control of the voltage by way of remaining available transformer OLTC buck-taps;
- Downstream export ratings that may limit the magnitude of the reverse power flowing back into the upstream network.

### 3.7.10. Interpreting 'energy at risk'

When there is an import limitation, 'energy at risk' is an estimate of the annual energy that would not be supplied to the load if a zone substation network asset were out of service during critical import times, for a given maximum demand forecast and import rating.

Furthermore, when there is an export limitation, 'energy at risk' is an estimate of the annual energy that would need to be curtailed from generation sources if a zone substation network asset were out of service during critical export times, for a given minimum demand forecast and export rating.

Generally, the worst-case outage for zone substation risk is outage of a transformer, and this condition is referred to as its 'N-1' rating. The capability of the station with all transformers in service is referred to as its 'N' rating. The relationship between the N and N-1 ratings of a station and the energy at risk is depicted in Figure 6.

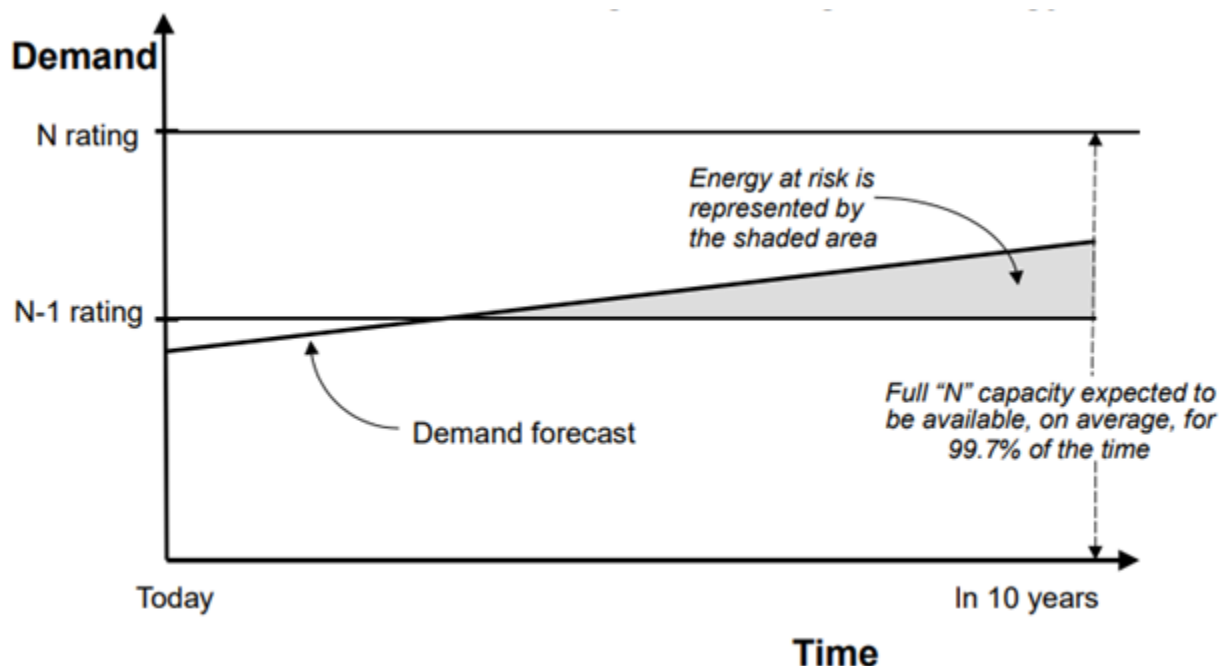

**Figure 6: Relationship between N rating, N-1 rating and energy at risk**

This chart is equally applicable for import and export conditions. In the case of import, maximum demands and import ratings are depicted as positive numbers, whereas in the case of export, minimum demands and export ratings are depicted as negative numbers.

While it depends on the condition of the individual asset, it is expected that:

- On average over the long term, each transformer will be unavailable for 19 hours per year.
- Under normal operating conditions, there will typically be more than adequate zone substation capacity to supply all demand.
- The risk of prolonged outages of a zone substation transformer leading to load interruption is typically very low.

### 3.7.11. Assessing service level risk

AusNet risk-cost model quantifies the benefits of potential investment options by comparing base service level risk, assuming no risk mitigation action is taken, with the reduced service level risk assuming the credible option is place. The investment cost to implement the credible option is then subtracted from the monetised benefit to compare credible options and identify the option that maximises the net economic benefit (the proposed preferred option).

The initial screening assessments presented in the DAPR only present the base level risk, without attempting to quantify of the residual risk, and therefore net benefit, of the various options presented.

The areas of service level risk costs, and risk cost reduction benefits, that AusNet can consider include:

- Supply risk.
- Safety risk.
- Reactive replacement.
- Environment risk.
- Operations and maintenance costs.
- Losses.

### 3.7.12. Reliability of zone substation assets

AusNet determines the probability of asset failure from results generated using statistical distributions fitted to health scores, whilst also considering machine learning outputs (where applicable). The broad categories taken into consideration by both methodologies include asset service age, asset physical condition (observed and measured), asset location, and duty factor (or utilisation).

Using the Weibull statistical distribution, future asset probability of failure and remaining life are estimated.. More details can be found in AMS 01-09.

### 3.7.13. Methodology for assessing sub-transmission loop supply risk

The methodology for assessing supply risk on sub-transmission loops includes assessing the magnitude, probability and impact of loss of load (or curtailment of generation) for each sub-transmission loop. Consequential loss of supply to customers is expected if a critical sub-transmission line outage occurs whilst the loop is operating above its N-1 voltage collapse limit or above its N-1 thermal rating.

The following key data are calculated for each sub-transmission line:

- **Hours at risk:** For a given maximum (or minimum) demand forecast, this is the number of hours per annum that a sub-transmission loop operates beyond its firm import (or export) rating.
- **Load at risk (or generation at risk):** For a given maximum (or minimum) demand forecast, this is the maximum amount of load (or generation) that would be shed should a failure of a 66 kV line occur, due to an outage occurring coincident with operation of the loop beyond its N-1 import (or export) rating.
- **Energy at risk:** This is the amount of energy, weighted by the demand conditions considered (10% POE and 50% POE), that would not be able to be imported or exported from a sub-transmission loop, assuming an outage of a line within that loop in that particular year. This measure provides an indication of the magnitude of energy that would not be supplied to the load during import (or the amount of generation curtailment needed during export) in the unlikely event of a major network asset outage.
- **Expected unserved energy:** This is the energy at risk weighted by the probability of potential network asset outages and their repair times. This measure provides an indication of the amount of energy, on average, that will not be imported (or exported) in a year, considering the low probability part of the sub-transmission loop fails and is out of service.

Supply risk assessments for each individual sub-transmission loop provide estimates of energy at risk and expected unserved energy based on the demand forecasts.

### 3.7.14. Methodology for assessing supply risk at transmission connection points

The methodology for assessing supply risk at transmission–distribution connection points involve evaluating three key dimensions: magnitude, probability, and impact of potential loss of load or curtailment of generation at each terminal station. This structured approach ensures that both the likelihood and consequences of supply interruptions are systematically analysed.

Comprehensive details regarding the supply risk assessment process, along with the specific risks associated with each terminal station, are documented in the TCPR.

### 3.7.15. Outages considered

In estimating the expected cost of zone substation asset and sub-transmission line outages, this report considers system normal condition ('N') and the first order contingency condition ('N-1') only. It is recognised that there is a significant amount of energy at risk if two lines of a sub-transmission loop or two transformers in a zone substation are out of service at the same time, due to a major outage. However, the probability of such an event occurring during peak loading periods is very low and is therefore not considered in the initial screening studies presented in the DAPR.

Where relevant, multiple contingency risk is included in detailed assessments undertaken prior to network investment.

### 3.7.16. Base Availability parameters

Estimates of the expected unserved energy of each zone substation and sub-transmission loop must be based on the expected reliability performance of the relevant power transformers and sub-transmission lines. The basic reliability data for power transformers and sub-transmission lines has been established and is shown Table 2.

**Table 2: Statistical availability data for zone substation power transformers and sub-transmission lines**

Major plant item	Expected asset outage duration due to a major failure (hours per year)	Interpretation
Power Transformer	Varies per transformer depending on transformer condition.	Each power transformer has it's own individual duration based on it's location, condition and various other factors.
Urban Sub-transmission Line	1 hr/line/year	On average, each line would be expected to have one failure per annum each with a duration of one hour.
Rural Sub-transmission Line	2hrs/line/year	On average, each line would be expected to have two failures per annum each with a duration of one hour each.

### 3.7.17. Feasible options for meeting forecast demand

Developed options for a network limitation may include demand management or other non-network solutions, refurbishment, replacement, augmentation, or a combination of these solutions. The options for zone substation and sub-transmission loop energy at risk is economically assessed to identify feasible solutions.

Network support in the form of demand management contracts and/or embedded generation, may individually or in combination with network augmentation, form feasible options for the elimination or mitigation of constraints.

## 3.8. Significant changes compared to previous year

This section provides details required by schedule 5.8 (a) (5) in covering any aspects of forecasts and information provided in the DAPR that have changed significantly from those presented in the preceding year.

### 3.8.1. Key Changes Relating to REFCL Plans

The following feeders are forecasted to exceed their operating limits due to capacitance growth by 2030. Network evaluation will be required to determine future works to maintain compliance.

- KLK11
- SMR Bus 2
- WOTS Bus 1
- WOTS25
- WYK Bus 1

### 3.8.2. Key Changes Relating to Southeastern Growth Corridor

The Southeastern Growth Corridor<sup>6</sup> is a rapidly developing region encompassing the municipalities of Casey and Cardinia. Last year's DAPR included the Pakenham South Zone Substation as an identified area of elevated expected unserved energy (EUE).

Demand forecasts have been updated following the extremely hot summer of 2024/2025 and the developments progressing rapidly in the **Pakenham South Employment Precinct Structure Plan (PSP)<sup>7</sup>, Officer South Precinct Structure**

<sup>6</sup> [Victorian Planning Authority – The South East Growth Corridor Plan](#), Victorian Planning Authority (VPA), 2012.

<sup>7</sup> [Pakenham South Employment Precinct | Creating Cardinia](#), Creating Cardinia, 2024

**Plan (PSP)<sup>8</sup>, Greater Clyde South and Cranbourne West** areas has reinforced the need for a broader, coordinated program of works supporting Victorian planning authority business plans(2024/25) and 10-year plan for Melbourne's green fields. This program incorporates the following key updates since last year:

- **Pakenham South and Officer Supply Area:** Pakenham South new zone substation (included in last year's DAPR) and new distribution feeders.
- **Greater Clyde South Supply Area:** Construct new CLN32 and CLN33 22kV feeders.
- **Cranbourne West Supply Area:** Construct a new 22kV feeder

### 3.8.3. Key Changes Relating to Northern Growth Corridor

The Northern Growth Corridor, located on the urban fringes of Melbourne's northern suburbs, is a major greenfield development area identified by the Victorian Planning Authority to accommodate significant population and economic growth. The Mitchell Shire (which Beveridge is a part of) is expected to grow annually at an average of 6.0% between 2021 and 2036. The City of Whittlesea (which Wollert is a part of) is expected to grow annually at an average of 2.5% over the same period – both are among the higher growth areas across the Victorian local government areas (LGA).

The program incorporates the following key updates since last year:

- **Wollert Supply Area:** Wollert new zone substation (Included in last years DAPR) and three new distribution feeders by 2028 and an additional feeder by 2029-30.
- **Beveridge Supply Area:** Beveridge new zone substation and five new distribution feeders.
- **SMTS-BVE-KMS:** 66kV Line Augmentation

See section 9 and 6.1.5 for further details on the proposed projects to cater for the northern growth corridor.

---

<sup>8</sup>[Officer South \(Employment\) - VPA](#), Victorian Planning Authority (VPA), 2024

## 4. Forecasts for the forward planning period

This section summarises the methodology applied in developing maximum and minimum demand forecasts and presents the actual and forecast demand for the five-year forward-looking period, as required under schedule 5.8 (b) of the NER.

### 4.1. Demand forecasting methodology

We prepare 15-year forward-looking demand forecasts annually for AusNet transmission connection assets, zone substations and distribution feeders. They are prepared for 10%, 50% and 90% Probability of Exceedance (POE) conditions, for both maximum and minimum demands, at different seasons during the year. At a high level, the following inputs are incorporated:

- Historical data, including customer numbers and rooftop PV capacity
- Forecast spatial customer numbers and rooftop PV capacity
- Historical and future estimates of electrification trends (e.g., EVs and gas electrification)
- Historical maximum and minimum operational demands at 30-minute intervals
- Historical weather-related and solar variables (e.g., temperature, wind, humidity and solar irradiation) at 30-minute intervals
- Information on public and school holidays
- Recorded embedded generation including wind as well as large solar generators at 30-minute intervals.

The process is described in more detail below.

#### 4.1.1. Spatial demand forecasting process

There are seven key steps in the current spatial and trend analysis forecasting process:

1. Assemble historical data.
2. Forecast spatial customer numbers and rooftop PV capacity.
3. Model unitised (per capita) underlying half-hourly demand, in two separate but complementary steps, which take account of historical temperature and other factors.
4. Forecast the impact of electrification, driven by EVs and gas electrification.
5. Simulating the future.
6. Presenting the maximum and minimum demand forecasts in terms of different POEs.
7. Validate spatial demand forecasts and include post-modelling adjustments.

Each of these seven steps are explained in further detail below.

##### 4.1.1.1. Step 1 – Assemble historical data

###### Customer numbers and PV capacity

Customer numbers and growth rates are a major driver of future demand, particularly spatial demand, forecasts. Historic customer numbers and PV capacities are extracted by asset and customer type from the tariff database and spatial asset database to provide both a launch point for the forecasts and a trend on which to inform projections over the forecast period.

###### Operational demand

Operational demand on various network elements (such as feeders and zone substations) is sourced from OSI-Pi, which records SCADA sensor data. After extraction, these data sets are cleansed of any abnormal readings, which

can arise from data errors or temporary changes to network configuration including load transfers. The resultant dataset is used as the basis for calculating the underlying demand, which is a key element of the forecast.

### Embedded generation (non-rooftop PV)

Each embedded generator's generation data is extracted from the advanced metering infrastructure (AMI) interval database and added back into our operational demand.

### Weather and solar variables

Weather data including temperature, wind speed and humidity relevant to each feeder and zone substation is extracted from AusNet's analytics platform, which is populated by postcode level time series from WeatherZone's satellite data.

The electricity generated by the rooftop PV panels depends on the panel capacity and also the solar variables (e.g., Solar irradiance). To estimate the total PV generation, we use the same data source as weather variables.

### Electrification trends

The electrification trends including transport electrification (the increasing number of EVs) and gas electrification (people switching from gas to electricity) are two main drivers of electricity demand in the future. In order to forecast the impact of EVs, we require detailed information on EV penetration across AusNet's network. For gas electrification, we require the number of existing gas customers, preferably by location.

## 4.1.1.2. Step 2– Forecast customer numbers and rooftop PV forecasts

Customer number forecasts are compiled with reference to both the historical trend in customer growth and the Victorian government's projections of structured private dwellings (SPD) in the Victoria in Future (VIF) planning publication.<sup>9</sup> The base forecast follows the historical trend and then is adjusted based on the VIF forecast on continuation or changing in the pace or direction of the exiting trend in the broader region. The forecasting approach here is a middle-out one, meaning that we start at the zone substation level and then follow a bottom-up approach for terminal and network level forecasts and a top-down approach for feeder level forecasts. This approach produces residential customer numbers, and commercial customer numbers are predicted based on the existing commercial to residential ratio.

A similar approach is applied to forecast PV capacity (and count). The only major difference is that, instead of the VIF data, we use the PV capacity forecasts mentioned in AEMO's latest Inputs, Assumptions and Scenarios (IASR) to adjust our PV capacity trends. The PV counts forecasts are then obtained by considering the PV penetration rate (PV capacity/Customer count) growth of different assets.

## 4.1.1.3. Step 3 – Model underlying half-hourly demand

The total electricity consumed by the customer is denoted as underlying demand. Historically the electricity load on the network (operational demand) and underlying demand were the same. But, over time, with the installation of rooftop solar PV panels and other embedded generators, a significant gap between these two is emerging. Our focus here is modelling the underlying demand and then estimating operational demand based on PV penetration rate and other related factors. In sum, the underlying is calculated as,

$$\text{Underlying Demand} = \text{Operational Demand} + \text{Embedded Generation} + \text{Rooftop PV Generation}$$

Where rooftop PV generation is calculated using PV capacity and solar data as,

$$\text{Rooftop PV Generation} = \text{PV Capacity} * \text{PV Generation per Capacity Based on Solar Factors} * \text{Efficiency Factor}$$

## 4.1.1.4. Step 4 – Forecasting the impact of electrification

### Forecasting load from EVs

The forecast number of EVs for each network asset (Feeders, Zone Substations, Transmission Connection Point and the Distribution Network) is produced for each customer type (Residential, Small and Medium Business, and Large Business). For each component, a bottom-up approach is adopted, starting with feeders and moving up to the next network level.

The EV penetration ratios for different geographical areas are estimated by comparing customer numbers with EV sales data obtained from the Victorian Department of Transport and Planning, disaggregated to postcodes to determine the level of EV penetration across our network. Future penetration ratios are predicted using data from

<sup>9</sup> <https://www.planning.vic.gov.au/land-use-and-population-research/victoria-in-future>

AEMO's latest IASR , which contains projected EV counts and load profiles for Victoria. Our existing EV penetration ratios are increased at the same growth rate as AEMO's forecast.

The forecast method produces the following forecast EV load:

$$\text{EV Load (kW)} = \text{Number of EVs} * \text{Share (\%)} \text{ in each charging profile} * \text{Load (kW)} \text{ per EV in each charging profile}$$

The resulting EV Load (kw) for each half-hour interval for each year is adopted in the demand forecasting process.

#### Forecasting gas electrification load

To estimate the load that results from gas electrification, we use the below formula:

Gas-Electrification Load (kw) =

- (1) Gas penetration rate (% , percentage of customers with gas connection) multiplied by
- (2) Electrification rate (% , percentage of customers switching from gas to electricity) multiplied by
- (3) Impact on electricity consumption (% , percentage for different seasons and for different times per day) multiplied by
- (4) Base electricity consumption (kw), for different seasons and for different times per day).

The final output of this step is a half-hourly load per season (kw), which will be used in the next step, simulating the future.

#### 4.1.1.5. Step 5 – Simulating the future

To simulate the future conditions that explain the electricity demand, we use a bootstrap method. We go through the historical observations of inter-related temperature, wind, humidity, solar, holidays and season variables and randomly select 200 sets of explanatory variables. In doing so, we use a block bootstrap with variable blocks method that, first, increase the number of existing scenarios to choose from and, second, maintains the statistical characteristics of the original explanatory variables.

The bootstrapped set of explanatory variables are used to estimate underlying demand using the model developed in step 3. We bootstrap solar variables along with the other explanatory variables and then calculate the operational demand from the estimated underlying demand. These are then used to extract seasonal maximum and minimum operational demands.

The output of the simulation step is 200 maximum and 200 minimum values, for each season and demand year.

#### 4.1.1.6. Step 6 – Presenting maximum and minimum demand forecasts as POEs

The simulated maximum and minimum demands are used to extract different probabilities of exceedance (POE). POE10, POE50 and POE90 are the three most used ones for network planning purposes. Starting with the maximum demand POE10 is equal to the 90th percentile of the simulated series, where only 10% of modelled outcomes exceeded that value. In an analogous way, POE50 and POE90 are equal to 50th and 10th percentiles of the simulated maximum demand, respectively.

In the case of the minimum demand, however, there is a slight difference in definition. POE here means the probability of operational demand going lower than a specific value. Therefore, POE10, POE50 and POE90 are exactly 10th, 50th and 90th percentiles of the simulated minimum demands, respectively. Whilst on face value this is a contradiction in terms (probability of exceedance reflects the chance of demand being lower than the value), this approach retains the intuition that a POE10 scenario is describing an outcome with a 10% chance of being more severe than the forecast (e.g. even lower demand than a minimum demand forecast predicts).

#### 4.1.1.7. Step 7 – Validate spatial demand forecasts and post modelling adjustments

Regional network planning engineers in conjunction with the sub-transmission planning engineers validate the relevant forecasts. Validation involves magnitude checks and trend line checks informed by knowledge of the loadings and network configuration changes recently completed and pending. Adjustments are undertaken to improve the accuracy of the forecast by addressing factors such as:

- large customers (above 1MVA) that are known to have connected recently or will connect in the near term (i.e. block loads)
- impact of known network projects that have recently been undertaken or are in train such as feeder reconfigurations

- Inconsistencies in AMI data that lead to offsets in the final forecast.

We apply post model adjustments for block loads, assessing actual connection requests for loads over 1MVA that are well progressed and are expected to proceed.

Post-model adjustments are also applied to demand forecasts to include the impacts of energy efficiency, behind-the-meter (BTM) batteries and business electrification. Incorporating these drivers into the process described above, rather than as post-model adjustments, is a future improvement that has been identified.

## 4.2. Network Capacitive Current Forecasting Methodology

To ensure the ongoing compliance of the REFCLs (refer Section 4.7.1), a forecast of network capacitive current was developed. The forecasts were prepared following a capacitive current forecasting methodology developed by AusNet with input from The Centre for International Economics (The CIE).

The forecasting methodology considers the following components which are considered the primary drivers of capacitive current growth:

- Determine the length of underground and overhead cable per new customer
- Determine types of customers (residential, commercial, and industrial)
- Historical cable growth trend per customer class on each feeder
- Annual customer number forecast is used directly for each feeder and customer class, this would more accurately align the cable requirements to the timing of expected customer numbers
- Considering actual cable types and lengths from the existing network
- Transformer capacitance even though minimal in comparison to cables was added based on existing installed transformers

To implement this approach further work by AusNet has also been conducted to check the accuracy of model by comparing the model analysis with current actual outcomes by carrying out the summation of capacitance from individual cable types and associated lengths that aligns to the overall measured capacitance.

The analysis undertaken to derive the numbers has provided a more robust relationship between customer numbers and cable requirements. Furthermore, the model incorporates an important feature to reflect changes in capacitance due to introduction of proposed isolation transformers on selected feeders which will have an impact on reducing capacitance hence forecast is adjusted accordingly.

## 4.3. Network Capacitive Current Forecasts

Table 3 presents the capacitance current forecast for each REFCL zone substation. The dark grey shaded cells highlight where the capacitance forecast exceeds the arc suppression coil (ASC) limits for the number of ground fault neutralisers (GFNs) installed at the zone substation. For zone substations that do not yet have a REFCL installed and are therefore yet to have their ASC limit determined through field measurement, an ASC limit of 100A has been assumed.

**Table 3: Capacitance Forecast Results (as of December 2025)**

ZSS	Region	No. of feeders	No. of REFCLs	Bus ID	ASC	2025 Capacitive Current	2030 Capacitive Current
					Limit		
BDL	East	8	2	BDL BUS 3	149	137	148
				BDL BUS 4	113	143	159

BGE	Central	6	2	BGE BUS 1	89	88	89
				BGE BUS 2	109	118	119
BGEBSY	Central	1	1	BGEBSY	93	88	88
BN	Central	5	1	BN BUS 1	137	100	105
				BN BUS 2			
BNBVT	North	1	1	BNBVT BUS 1	66	73	75
BWA	North	4	1	BWA BUS 2	114	76	87
ELM	Central	8	2	ELM BUS 2	145	129	134
				ELM BUS 3	120	106	109
FGY	Central	10	2	FGY BUS 1	116	76	78
				FGY BUS 2			
				FGY BUS 3	61	45	46
KLK	Central	3	1	KLK BUS 1	144	91	96
				KLK BUS 2			
KLO <sup>10</sup>	Central	2	2	KLOKDB	138	91	468
				KLOKBV	137.6	75	163
KMS	North	2	1	KMS BUS 1	107	92	105
LDL	Central	8	2	LDL BUS 1	125	124	128
				LDL BUS 2	120	133	144
LLG	Central	3	1	LLG BUS 1	105	99	106
MOE	East	8	2	MOE BUS 1	93	66	69
				MOE BUS 2	79	79	84
MSD	North	8	1	MSD BUS 1	110	85	92

<sup>10</sup> KLO is an area of high residential growth. The forecasts have been adjusted to reflect the maximum growth rate anticipated. Development of a standard or strategy to mitigate / eliminate the forecasted excess capacity is underway. Strategies may involve:

- Offloading sections of KLO14 and KLO24 existing network to new Beveridge Feeders, after the new BVE ZSS is commissioned.
- Developing a standard to ensure any new residential developments can be undergrounded and isolated via isolation transformer or be part of a fully undergrounded bus group exempted from REFL

MYT	North	4	1	MYT BUS 1	71	60	62
				MYT BUS 2			
RUBA	North	3	1	RUBA BUS 1	76	80	84
				RUBA BUS 2			
RWN	Central	7	1	RWN BUS 2	119	120	122
				RWN BUS 3			
SLE	East	4	1 <sup>13</sup>	SLE BUS 1	122	125	138
				SLE BUS 3			
SMR	North	6	2	SMR BUS 1	77	63	69
				SMR BUS 2			
WGI	East	8	1	WGI BUS 2	87	80	87
				WGI BUS 3			
WN	North	7	2	WN BUS 1	150	112	117
				WN BUS 2			
WOTS	North	6	2	WOTS BUS 1	90	114	136
				WOTS BUS 2			
WYK	Central	4	2	WYK BUS 1	86	107	108
				WYK BUS 2			

## 4.4. Five-year forecasts

The asset loading forecasts presented herein are for the five-year forward planning period. They address summer and winter separately and provide observations (actual loadings) from 2025 and forecasts for the five-year forward planning period of 2026-2030.

50% POE and 10% POE represent the probability of exceedance demand. Each demand is expressed as the probability or the likelihood the forecast would be met or exceeded. For example, a 10% probability of exceedance

(POE) demand, represented in the table as 10% POE, implies there is a 10% probability of the actual demand going beyond the forecast maximum (or minimum) demand values<sup>11</sup>.

#### 4.4.1. Maximum and minimum demand forecasts at the transmission-distribution connections points

Schedule 5.8 (b)(2)(i) of the NER requires load forecasts at the transmission-distribution connections points. However, clause 5.13.2(d) stipulates that a DNSP is not required to include in its DAPR information required in relation to transmission-distribution connection points if it is required to do so under jurisdictional electricity legislation.

DNSPs in Victoria are required, under clause 19.3 of the Victorian EDCoP, to publish maximum and minimum load forecasts at the transmission-distribution connection points in the [TCPR](#). The current TCPR covers the period of 2026-2035 and to avoid duplication the forecasts are generally not repeated in this report.

#### 4.4.2. Maximum demand forecasts for sub-transmission lines

This section provides details required by schedule 5.8(b)(2)(ii) of the NER in covering load forecasts for sub-transmission lines and provides the additional information specified by (iv) to (ix). Sub-transmission lines are grouped into normally interconnected loops or circuits.

Table 32 from the Appendix E.1 present:

- The firm capacity of sub-transmission loops during import conditions (i.e., the 'N-1' import rating), being the capacity of the loop with the worst-case line outage and the import rating being reached on one of the remaining lines.
- The historical actual maximum demand of the line or loop (non-diversified aggregate loop zone substation loading), and the line or loop power factor at the time of maximum demand; and
- The maximum demand forecasts for winter and summer inclusive of line losses under single contingency (non-diversified aggregate loop zone substation 10% POE loading).

Table 34 from the Appendix E.3 presents:

- The total capacity of the AusNet sub-transmission lines or loops during import conditions (i.e., the 'N' import rating).
- The load transfer capacity (to zone substations outside the 66 kV line or loop at time of need, 10%POE).
- The embedded generation capacity.
- The estimated hours per year that 95% of the line or loop maximum demand is expected to be reached in winter and summer.

Further information on individual Sub-transmission line forecast can be found in:

- Rosetta portal (<https://dapr.ausnetservices.com.au/>)

#### 4.4.3. Maximum demand forecasts for zone substations

This section provides details required by schedule 5.8(b)(2)(iii) of the NER in covering load forecasts for zone substations and provides the additional information specified by (iv) to (ix).

Maximum demand forecasts for zone substations are provided in Table 35 in Appendix E.4 and additional information in Table 37 in Appendix E.6.

Table 35 presents:

- The total capacity of the AusNet zone substations during import conditions (i.e., the 'N' import rating), being the total station nameplate capacity.
- The firm capacity of the zone substation during import conditions (i.e., the 'N-1' import rating), being the capacity of the station with the worst-case transformer outage and the import rating being reached on one of the remaining transformers.

<sup>11</sup> Regional Demand Definition, <https://www.aemo.com.au/Electricity/National-Electricity-Market-NEM/Data/Market-Management-System-MMS/Generation-and-Load>

- The historical actual maximum demand of the zone substation.
- The power factor at the time of maximum demand; and
- The maximum demand forecasts (10% POE) for winter and summer.

Table 37 presents:

- The load transfer capacity (to other zone substations at time of need, 10%POE);
- The embedded generation capacity; and
- The estimated hours per year that 95% of the maximum demand is expected to be reached in winter and summer.

#### 4.4.4. Minimum demand forecasts for sub-transmission lines

This section provides details required by schedule 5.8(b)(2A)(ii) of the NER in covering forecast use of distribution services by embedded generating units for sub-transmission lines and provides the additional information specified by (iv) to (vii). Sub-transmission lines are grouped into normally interconnected loops or circuits.

Table 33 from the Appendix E.2 presents:

- The total capacity of the AusNet sub-transmission lines during export conditions (i.e., the 'N' export rating);
- The firm capacity of sub-transmission loops during export conditions (i.e., the 'N-1' export rating), being the capacity of the loop with the worst-case line outage and the export rating being reached on one of the remaining lines;
- The historical actual minimum demand of the line or loop (non-diversified aggregate loop zone substation loading);
- The line or loop power factor at the time of minimum demand;
- The 10% POE minimum demand forecasts for each year. A negative minimum demand represents an export condition; and
- The estimated hours per year that 95% of the line or loop minimum demand is expected to be reached in the year.

#### 4.4.5. Minimum demand forecasts for zone substations

This section provides details required by schedule 5.8(b)(2A)(iii) of the NER in covering forecast use of distribution services by embedded generating units at zone substations and provides the additional information specified by (iv) to (vii).

Table 36 provided in Appendix E.5 presents:

- The total capacity of the AusNet zone substations during export conditions (i.e., the 'N' export rating);
- The firm capacity of the zone substation during export conditions (i.e., the 'N-1' export rating), being the capacity of the station with the worst-case transformer outage and the export rating being reached on one of the remaining transformers.
- The historical actual minimum demand of the zone substation.
- The power factor at the time of minimum demand;
- The 10% POE minimum demand forecasts for each year. A negative minimum demand represents an export condition; and
- The estimated hours per year that 95% of minimum demand is expected to be reached in the year.

## 4.5. Future Assets

Consistent with the requirements from schedule 5.8 (b)(3) of the NER, this section provides details regarding forecasts of future transmission-distribution connection points (and any associated connection assets), sub-transmission lines and zone substations, including for each future transmission-distribution connection point and zone substation.

### 4.5.1. Transmission to distribution connection points

Clause 5.13.2(d) of the NER stipulates that a DNSP is not required to include in its DAPR information required in relation to transmission-distribution connection points if it is required to do so under jurisdictional electricity legislation. DNSPs in Victoria are required by the Victorian EDCoP Clause 19.3 to publish load forecasts at the transmission-distribution connection points in the TCPR for the next ten-year period. The DNSPs assess the Energy at Risk (EAR) at each transmission to distribution connection point based on the latest demand forecast and jointly publish the TCPR in December annually. The TCPR discuss the EAR at each connection point, feasible options to alleviate EAR and current projects in progress. Please refer the latest TCPR<sup>12</sup> for more information.

### 4.5.2. Sub-transmission lines

Following sub-transmission augmentations are expected to progress subjected to the RIT-D and EDPR (Electricity Distribution Price Review) outcomes.

- Augmentation of the Morwell Terminal Station (MWTS) to Traralgon (TGN) and TGN to Mafra (MFA) 66kV sub transmission lines.
- Augmentation of the Morwell Terminal Station (MWTS) to Leongatha (LGA) 66kV sub transmission lines
- Installation of a second 66kV sub transmission line between Wodonga (WO) to Barnawartha (BWA) .
- Installation of a new 66kV sub-transmission line between Cranbourne Terminal Station (CBTS) to Officer (OFR)
- Augmentation of South Morang Terminal Station (SMTS) to Kilmore South (KMS) 66kV sub transmission line

More information is available in section 8.

### 4.5.3. Zone Sub Stations

The following new zone substations are forecasted to be required within the next five-year period.

- Beveridge Zone Substation (BVE): See section 9.15 for further details
- Wollert Zone Substation (WLT): See section 9.11 for further details
- Pakenham South Zone substation (PHMS): See section 9.13 for further details

## 4.6. Forecasts of the DNSP performance against STPIS reliability targets

This section provides details required in schedule 5.8 (b)(4) of the NER covering forecasts of performance against reliability targets in the Service Target Performance Incentive Scheme (STPIS). Details of the STPIS are found at the Australian Energy Regulators website<sup>13</sup>.

Table 4 shows AusNet network reliability performance against STPIS targets for the FY23/24 (1/7/2023 – 30/6/2024) and the new Financial Year period FY25/26 (1/7/2025 – 30/6/2026).

AusNet has achieved improved performance against SAIDI and SAIFI targets in recent years. Whilst the forecasted RY26 results for Unplanned SAIDI and SAIFI for rural long feeders shows underperformance compared to the targets. To improve these results, some (not all) of the key reliability improvements initiatives include:

- Conducting detailed deep-dive assessments of the worst-served areas.
- Expanding the technology, capability, and coverage of automation schemes.
- Reducing customer density within isolatable network sections to minimise outage impact.
- Establishing incident-focused working groups to analyse causal factors and identify targeted improvements.

<sup>12</sup> A copy of the latest Transmission Connection Planning Report (TCPR) and Terminal Station Demand Forecasts can be viewed at AusNet website: [AusNet - Rosetta Data Portal \(ausnetservices.com.au\)](https://www.ausnet.com.au/rosetta).

<sup>13</sup> A copy of the Electricity Distribution Network Service Providers' Service Target Performance Incentive Scheme can be viewed at the Australian Energy Regulator's website: <http://www.aer.gov.au/>

Table 4: AusNet network reliability performance against STPIS targets

Measure	Feeder Class	5yr	RY24 Actual		RY25 Actual		RY26 F'cast
		Target	Total	Net <sup>14</sup>	Total	Net <sup>16</sup>	Net <sup>14</sup>
Unplanned SAIDI	Urban	87.190	392.035	110.388	132.967	83.108	76.615
	Rural Short	195.160	1091.926	169.571	667.766	271.438	177.989
	Rural Long	293.692	1605.178	281.800	1,119.038	462.673	307.064
SAIFI	Urban	0.891	1.438	0.984	0.835	0.708	0.809
	Rural Short	2.007	2.189	1.245	2.612	1.869	1.844
	Rural Long	2.628	3.917	2.020	3.684	2.536	2.697
Unplanned MAIFI	Urban	2.817	3.452	2.949	2.859	2.578	2.658
	Rural Short	5.657	4.799	4.220	5.221	4.675	5.033
	Rural Long	9.920	7.610	6.534	8.411	7.714	9.026

## 4.7. Factors that may have material impact on distribution network

This section provides details of factors other than demand growth that may have a material impact on the AusNet network. These factors include network capacitive current, fault levels, voltage levels, other power system security requirements, quality of supply, ageing and potentially unreliable assets. The contents of this section cover schedule 5.8 (b)(5) of the NER.

- Network capacitive current:** With the implementation of rapid earth fault current limiter (REFCL) technology, the size and balance of network capacitance has become increasingly important and has and is expected to continue to be a primary driver of network augmentation into the future.
- Fault levels:** Fault levels in certain areas of the distribution network are reaching its allowable limits due to connection of new embedded generators and network augmentations.
- Voltage levels:** Voltage levels are generally maintained within the distribution code limits. However, in certain areas voltages are outside code limits and corrective actions are taken when these violations are observed. A survey undertaken by an external agency shows that the steady state voltage received by customers are generally closer to the upper boundary of the allowable limits and need to be carefully managed.
- Other security system requirements:** There are number of zone substations fed from a single sub transmission line and/or single transformer or un-switched zone substations. These sites will have supply security issues when a credible contingency occurs. Improvements in system security for these sites will be considered when an augmentation is proposed either due to increase loading or ageing assets.
- Quality of supply to other network users:** Comprehensive system studies are carried out prior to connecting disturbing loads to determine suitability of the proposed new customer connections an corrective actions are taken where necessary to maintain quality of supply to all customers within the code requirements.

<sup>14</sup> End of year forecast, after removing exclusions, based on year-to-date actuals as at 31-10-25.

- **Ageing and increasing probability of failure:** AusNet Asset Management Strategy outlines the process undertaken to manage ageing and increasing probability of failure of assets.

These factors are discussed in more detail below:

### 4.7.1. Network capacitive current

The installation and application of REFCL technology are governed by two key pieces of legislation:

- Electricity Safety Act 1998; and
- Electricity Safety (Bushfire Mitigation) Regulations 2013.

The Electricity Safety (Bushfire Mitigation) Regulations 2013 defines part of the “Required Capacity” as, in the event of a phase-to-ground fault on a polyphase electric line, the ability to reduce the voltage on the faulted conductor in relation to the station earth when measured at the corresponding zone station for high impedance (25.4 kΩ) faults to 250V within 2 seconds.

For the REFCL to operate within the criteria, the magnitude of network dissymmetry (or network capacitive balance) must be reduced significantly and maintained within a narrow band. Moreover, the size (total capacitance) of the network must also be limited.

Compliance is achieved through the sensitivity equation:

$$R_f = \frac{U_{ph}}{I_{CE}} \left[ \frac{\left( \frac{1}{U_{ENT}} - 1 \right)}{d + k} \right]$$

Where:

$R_f$  (fault resistance) is legislated to 25.4kΩ

$U_{ph}$  (phase voltage) is fixed at 12.7kV

$U_{ENT}$  (trigger neutral voltage) is 3 times  $U_{EN}$  (standing neutral voltage) in per unit  $d$

(damping) is a network construction parameter (resistive leakage current) in per unit

$k$  (dissymmetry) is mostly the capacitive imbalance in per unit

$I_{CE}$  (total capacitance to earth) is the tune point in Amps

Of the equation, the two variables that are easiest to manipulate are  $k$  (capacitive balance) and  $I_{CE}$  (network capacitance size).

<p><math>k</math> (capacitive balance)</p>	<p>Should be large enough for the REFCL to tune (typically greater than 0 mA)</p> <p>Should be small enough to detect to allow the REFCL to detect faults less than 80mA ( but can be extend if <math>I_{CE}</math> is reduced)</p> <p>Should be balanced by remote controlled switching section, so the network stays compliant, and the ground fault neutraliser does trip the feeder if a field device operates</p>
<p><math>I_{CE}</math> (network capacitance size)</p>	<p>Should not be less than 20A because coil cannot tune well below this value.</p> <p>In general, and from a forward planning perspective, should not be more than 100A, although the actual limit is location specific because its affect by network damping and the level of capacitive balance.</p>

A capacitance forecast has been developed to assist in determining when the network capacitive current is nearing the limit of the sensitivity equation that defines the ability to achieve compliance and indicates augmentation is required.

### 4.7.2. Fault Levels

Fault level at any given point of the electric power supply network is the current that would flow in case of a short circuit fault at that point. The purpose of fault level calculations is:

- For selecting short circuit protective devices of adequate short circuit breaking capacity;
- For selecting circuit breakers & switches of adequate short circuit making capacity;
- For selecting busbars, busbar supports, cables & switches, designed to withstand thermal & mechanical stresses because of short circuit;
- To carry out current based discrimination between protective devices; and
- To indicate the level of system strength and a location’s ability to facilitate new generation.

Fault levels are determined utilising numerous factors including:

- Installed generation;
- Impedance of transmission and distribution network assets;
- Connected load including motors; and
- Network voltage.

Switchgear, plant, and lines in an electrical network have a maximum allowable three phase and single-phase to ground short circuit fault level rating. The EDCoP also specifies that embedded generators must not cause fault levels to exceed levels in the distribution network specified in Table 5. Fault levels at some terminal station 66 kV and 22 kV buses exceed these limits by agreement in Use of System Agreements for those stations. Fault level studies are carried out to ensure that the distribution system is operated within plant ratings and EDCoP requirements.

**Table 5: Distribution System Fault Levels**

Voltage Level (kV)	System Fault Level (MVA)	Short Circuit Level (kA)
66	2500	21.9
22	500	13.1
11	350	18.4
6.6	250	21.9
<1	36	50

The requirements place an obligation on system planners to ensure that:

- Any augmentation to the network will maintain short circuit fault levels within allowable limits.
- The addition of distributed generation or embedded generation which increases fault levels is assessed for each new connection to ensure limits are not infringed.
- When an augmentation such as a new zone substation, line upgrade or new transformer is contemplated that fault levels are checked to ensure that they do not exceed the allowable limits.
- Fault levels are commonly managed by splitting buses at stations when fault level would otherwise exceed limits.

### 4.7.3. Network Fault Level Issues

When fault levels reach the designed limits as outlined in the EDCoP (ref Table 5), the following corrective actions will be investigated, and appropriate fault level mitigation measured will be taken to comply with the code. These corrective actions include:

- Install 66 kV line reactors or 22 kV transformer reactors or 22 kV feeder reactors to reduce the fault levels.

- Shift the 22 kV feeder open points to transfer generation to a neighbouring station with a higher fault level margin.
- Operate the station with a normally open bus tie.
- Operate the station with one transformer as a hot standby.

As noted previously, comprehensive network studies are undertaken prior to connecting embedded generators and the proponents are advised of the corrective actions required to maintain fault levels within safe limits.

Fault Levels at a number of stations are reaching the allowable limits as described in Table 5 above. The stations with fault level issues are listed below, including the mitigation arrangements.

#### 4.7.3.1. Watsonia Zone (WT) Substation Fault Level Issue

Watsonia zone substation has a fault level mitigation arrangement where one transformer is maintained as a hot spare and does not share load with the other two transformers. This arrangement will continue until the proposed rebuild of Watsonia zone substation in the next EDPR period (2027-31) to maintain fault levels maintain below 13.1kA on 22 kV switchgear (assets).

#### 4.7.3.2. Morwell Terminal Station (MWTs) Fault Level Issue

Similarly, 66 kV buses at MWTs have been opened between Buses 1 and 2 and between 2 and 3 to maintain fault levels within allowable limits.

#### 4.7.3.3. Ringwood Terminal Station 22kV (RWTs 22kV) Fault Level Issue

Series reactors have been installed at RWTs on each of the 22 kV feeders to maintain fault levels below 13.1 kA. A new Neutral Earth Resistor (NER) has also been installed to further reduce Phase to Ground fault levels.

#### 4.7.3.4. Epping Zone Substation (EPG) Fault Level Issue

The previously noted EPG 22 kV bus fault level issue has been resolved due to the relocation of the Wollert Power Station connection to DRN ZSS.

### 4.7.4. Voltage Levels

Electricity distributors are obliged to maintain customer voltages within specified limits. Clause 20.4 of the Victorian EDCoP specifies the voltage levels that must be maintained at the meter or the point of supply to the customer's electrical installation.

Network voltage can be affected due to a number of factors including:

- Customer load
- Generation of electricity into the network (at various voltage levels)
- Transmission and distribution line impedances
- Transformer impedances
- Transformer and regulator tap positions
- Capacitors in the network (or other reactive power plant)
- Seasonal loading behaviour
- Non-compliance of inverter settings

Voltage levels from the respective connection points to customers' point of connections are managed by application of on-load-tap changes in zone substation transformers, reactive power compensations at various points in the network; line voltage regulators and utilising off-load taps in distribution transformers.

Due to increased penetration of solar PV over the last decade, maintaining voltage within EDCoP limits at customers' point of connections has become a challenge because of reverse power flows. However, these issues are monitored, and corrective actions are taken when necessary to minimise the impact on customers.

AusNet actively undertakes works to improve supply quality for customers connected to its distribution network. These works are carried out when voltage issues are identified through AMI meters or to respond to customer complaints regarding supply voltage. The steady state voltages monitored through dedicated power quality monitoring instruments and customers' AMI meters have revealed that there are many customers experiencing voltages close to the upper limit of the EDCoP requirements. As part of network planning activity, steady state voltages are brought back within the EDCoP limits where possible. neg

### 4.7.5. Negative Sequence Voltage

The following sub-transmission loops have been identified as having negative sequence voltage issues:

- East Gippsland sub-transmission network – zone substations NLA and CNR.
- SMTS–KLK–Rub A–KMS sub-transmission loop – zone substations KLK, Rub A and SMR.
- South Gippsland sub-transmission loop – zone substations FTR, LGA, WGI and PHI.
- GNTS–BN–MSD loop – zone substations MSD and MJG.
- WOTS–WO loop – zone substation WO.
- RWTS–RWN loop – zone substation RWN.
- RWTS–LDL–WYK loop – zone substation LDL.
- RWTS–BRA–BWR loop – zone substations BRA and BWR.

Although these loops were identified as having negative sequence voltage issues, AusNet has not received complaints from customers supplied from these loops and zone substations. Excessive amount of Negative sequence voltage can have adverse impact to some industrial customers (unbalance in supply adversely impacts induction motors by causing additional heat and reduction of full load speed) and increase network losses.

Negative sequence voltage (% of nominal voltage) should not vary by more than the amounts set out in S5.1a.7 clause of the NER. AusNet is actively monitoring the voltage unbalance<sup>15</sup> across its network and additional measures have been taken over the recent time as discussed in section 12.6.4.

### 4.7.6. Other power system security requirements

The NER clause 4.3.4 (g) – (i) requires DNSPs to plan and operate their networks in accordance with network stability guidelines published by AEMO. AusNet carries out its planning and network operations in accordance with these guidelines.

### 4.7.7. Quality of supply to other network users

AusNet undertakes system studies as part of the connection process when connecting disturbing loads such as embedded generators or large industrial customers, to investigate the impact on quality of supply to other network users. The network studies described above can also be undertaken by a consultant nominated by the customer in consultation with AusNet. The required network data will be provided to the respective consultant and the final report will be reviewed by AusNet and approved before the customer is allowed to be connected.

### 4.7.8. Ageing and Increasing Probability of Failure of Assets

AusNet has an ageing electricity distribution network, with a significant proportion of these assets approaching the end of their technical lives. Our asset management plans include specific tasks and activities required to optimise costs, risks and performance of the assets.

AusNet uses ISO 31000 Risk Management Guideline to manage the fleet of assets. The major assets are assessed to determine the likelihood of failure and the cost of failure. The results of the analysis are depicted on a 5x5 Risk matrix with a likelihood scale 1 to 5 (1 being very unlikely and 5 very likely) and a consequence scale 1 to 5 (1 being insignificant and 5 being catastrophic).

Risk mitigation activities, or treatments, are required to maintain risk by targeting reduction of PoF or CoF depending on the nature of the risk. Mitigation measures include asset replacement, asset refurbishment, inspections, testing or

<sup>15</sup> Voltage unbalance is measured as negative sequence voltage (% of nominal voltage) as per NER S5.1a.7

system redesign, and are achieved through capital projects or operational expenditure. Risk treatment options are described in the section on “Risk Treatment” in AMS 01-09.

Some examples of the risk mitigation activities include:

- Condition monitoring techniques are utilised to detect early stages of asset degradation before poor condition becomes a significant risk to the safety of personnel, network reliability and the environment. A range of condition monitoring techniques is used to monitor and analyse the mechanical and electrical condition and performance of the various asset classes to accurately forecast future augmentation and replacement requirements.
- Zone substation plant and equipment is subject to a combination of periodic and duty cycle inspection and maintenance programs derived from manufacturer recommendations and industry experience. Line assets are subject to cyclic inspection and other techniques such as automated image processing using high resolution aerial images, Smart Aerial Imaging and Processing (SAIP), for conductor condition assessment.

#### 4.7.9. System Strength Locational Factors and Corresponding Nodes

As per Schedule 5.8 (q) of the NER, AusNet is required to include in this report the system strength locational factor (SSLF) for each system strength connection point for which it is the Network Service Provider and the corresponding system strength node. The SSLFs and corresponding nodes are provided in Appendix F and can be found on AusNet [Subtransmission Ratings and Connections Dashboard](#).

## 5. Network Asset Retirements and De-ratings

This section, coupled with Section 9, addresses the requirements for reporting of network asset retirements and deratings as described in Schedule 5.8 (b1) and (b2) of the NER. The information is presented in two categories: Individual assets and Grouped assets.

The assets categories reflect the relative size or significance of the asset and the approach to management of asset retirement and replacement. Items listed in the individual asset category are usually the subject of a proactive planned retirement process. These assets are typically retired and, where proven to be economically feasible replaced. Items listed in the grouped asset category are usually retired and replaced as part of a program of work in response to inspection programs throughout the network.

The assets assigned to the individual and grouped asset categories are listed in Appendix C.

### 5.1. Individual asset retirement and de-ratings

Referring to AMS 01-09, asset retirements is a major component of asset risk management. The prerequisites for retirement or derating of assets:

- replacement or derating of an asset will result in a material risk reduction
- risks can't be feasibly managed through maintenance or refurbishment
- monetised risk exceeds the replacement cost – ie replacement is economic.

Where AusNet is planning or has committed to retire and, where economically justified, replace individual assets, these works are summarised in Section 9.

AusNet Zone Substation Transformer cyclic ratings is currently under review. The network limitations identified in Section 6.2. The cyclic ratings are based on daily load curves for each zone substation and are prepared in line with Australian Standard AS 2374.7 – 1997 Loading Guide for Power Transformers, as outlined in AusNet asset management strategy AMS 20-101.

### 5.2. Grouped asset retirement and de-ratings

Summaries of asset retirement and de-ratings of Grouped assets is contained in the Appendix. The asset statement for each Group provides an overview of the methodologies and assumptions used in the development of the asset management strategies that influence the retirement or de-rating of the asset group. The complete asset management strategies are available upon request to the contact outlined in the Disclaimer at the beginning this report. The complete asset management strategies were provided to the Australian Energy Regulator as part of the Electricity Distribution Price Reset submission.

## 6. System Limitations for Sub-Transmission Lines and Zone Substations

This section provides details required by schedule 5.8 (c) of the NER covering information on system limitations for sub-transmission lines and zone substations. The assessments and information on the limitations cover what is required in (1) to (5) and include:

- Estimates of the location and timing of the system limitations.
- Analysis of any potential load transfer capacity between supply points that may decrease the impact of the system limitation or defer the requirement for investment.
- A brief discussion of the types of potential solutions that may address the system limitation in the forward planning period.

Where an estimated reduction in forecast load or generation would defer a forecast system limitation for a period of at least twelve months, the following has been provided:

- An estimate of the month and year in which a system limitation is forecast to occur.
- The relevant connection points at which the estimated load or generation reduction may occur.
- The estimated reduction in forecast load or generation (MW), or improvements in power factor needed to defer the forecast system limitation.

None of the system limitations identified in Section 6 have an impact on the capacity at transmission-distribution connection points.

### 6.1. Sub-transmission line import limitations

This section discusses identified sub-transmission line import limitations. It assesses the limitation, its impact and, where possible, suggests potential solutions. Some minor limitations that exist under contingency conditions, but where there is sufficient load transfer capability to supply the load, are not discussed in detail in this section.

#### 6.1.1. CBTS-LYD-NRN-PHM-OFR-BWN-LLG-CLN-CBTS 66 kV loop

The Eastern Cranbourne 66kV sub-transmission loop, supplying over 114,000 customers, is supplied by the Cranbourne Terminal Station (CBTS) and consists of seven zone substations—Lysterfield (LYD), Narre Warren (NRN), Pakenham (PHM), Officer (OFR), Berwick North (BWN), Lang Lang (LLG) and Clyde North (CLN). A new Pakenham South (PSH) ZSS is expected to be commissioned around 2028. AusNet has identified increasing energy at risk in this network due to rapid demand growth in the South-East Growth Corridor. Maximum loop demand has exceeded its firm (N-1) capacity of 214 MVA. Forecasts indicate that maximum demand will exceed the loop capacity (N) of 320 MVA by summer (December-February) 2026/27 under summer 50% Probability of Exceedance demand forecast (PoE50). The network's thermal constraints are expected to escalate, with demand reaching 365 MVA in 2026 and 393 MVA in 2028 under summer PoE10 conditions. The most critical constraints are associated with the CBTS-BWN and CBTS-LYD 66kV line segments, with the worst-case scenario being the loss of the CBTS-LYD 66kV line, leading to an overload of the CBTS-BWN segment under peak demand conditions. After accounting for all possible transfers, the projected loop maximum demand will surpass the loop N rating of 320 MVA by 110 MVA in 2038. AusNet initiated this RIT-D to investigate and evaluate options to address the constraints in the Eastern Cranbourne 66kV sub-transmission loop, which are limiting the reliability of supply to the existing customers served by the loop and limiting the potential for new connections.

Figure 7 shows the single line diagram of this loop along with the constrained line segments (coloured in red) under various single order contingency events in this loop.

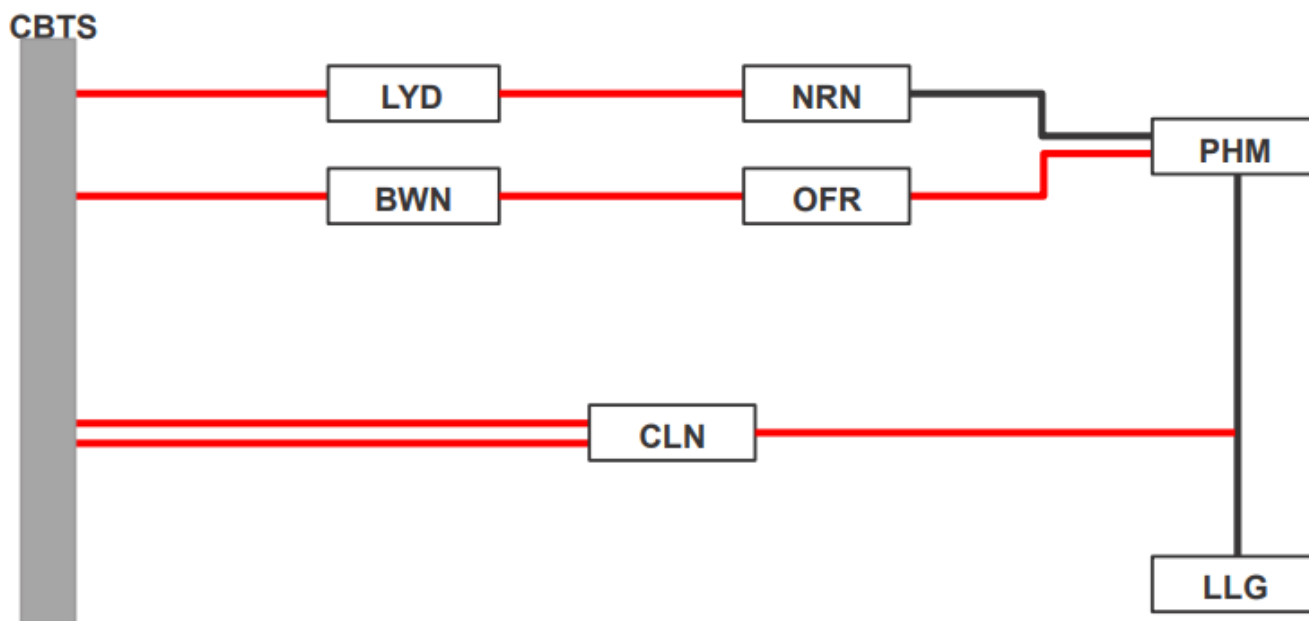

**Figure 7: CBTS-LYD-NRN-PHM-OFR-BWN-LLG-CLN 66 kV Loop**

A contingency plan has been developed to transfer load away via 22 kV links to the adjacent zone substations in the event of a line outage.

AusNet has also established an option to extend the 66 kV network to allow Lysterfield Zone Substation (LYD) and Narre Warren Zone Substation (NRN) to be supplied radially from East Rowville Terminal Station (ERTS), and BWN and OFR to be supplied radially from ERTS, thereby offloading this CBTS 66 kV loop, during network contingency events. While this contingency plan supports network supply capacity under contingency events, it requires LYD and NRN, as well as BWN and OFR to be supplied radially from ERTS, thereby significantly increasing the network supply risk for subsequent outages.

AusNet published a [Final Project Assessment Report \(FPAR\)](#) in November 2025 evaluating the following network and non-network options to select the option that provides the highest net economic benefits:

1. Option 1: Install a new Cranbourne Terminal Station to Officer (CBTS-OFR) 66kV line
2. Option 2: Install a new Cranbourne Terminal Station to Pakenham (CBTS-PHM) 66kV line
3. Option 3: Install a new Cranbourne Terminal Station to Pakenham South (CBTS-PSH) and new PSH-PHM 66kV lines  
PUBLIC RIT-D FPAR – East Cranbourne Capacity Enhancement
4. Option 4: Install a new Cranbourne Terminal Station to Lang Lang (CBTS-LLG) 66kV line
5. Option 5: Install a new 25 MW/100 MWh battery at OFR zone substation
5. Option 6: Connecting a 100 MW / 400 MWh utility BESS connected to 66kV bus at CBTS (submission received in response to the [DPAR](#))

The economic analysis demonstrated that Option 1: “Install a new Cranbourne Terminal Station to Officer (CBTS-OFR) 66kV line with 37/3.75 AAC conductor” provides the highest net economic benefits. The total capital expenditure of the preferred option (Option 1) including AusNet’s overheads and finance charge is estimated to be \$27.95 million (in real 2024).

### 6.1.2. LGA-WGI-PHI 66 kV loop

The Leongatha (LGA) to Wonthaggi (WGI) loop and radial 66 kV line to Phillip Island (PHI) supplies over 33,600 customers via the two zone substations at Wonthaggi and Phillip Island. This LGA – WGI 66 kV loop has energy at risk over the peak tourism seasons including school holidays, long weekends and special events such as the Motorcycle Grand Prix. An outage of either the LGA – LSSS, LSSS - WGI or LGA - LSSS/WGI 66 kV lines will result in voltage collapse of this network and loss of supply at both zone substations if loading exceeds 56.0 MVA, and load shedding if the thermal loading exceeds 32.0 MVA.

Maximum coincident demand occurs in summer and is expected to reach 74.5 MVA in December 2025, increasing to 77.6 MVA in December 2029 under PoE10 conditions. The BHWF output also reduces risk in this part of the network. Figure 8 shows the single line diagram of this loop along with the constrained line segment (coloured in red) under single order contingency.

In late-2020, AusNet published a request for proposals (RFP) to enter into a 4.95 MW / 10 MWh network support contract in the PHI area. The selected service provider, the Phillip Island Community Energy Storage System (PICESS), is now installed on the network and will provide network support when requested.

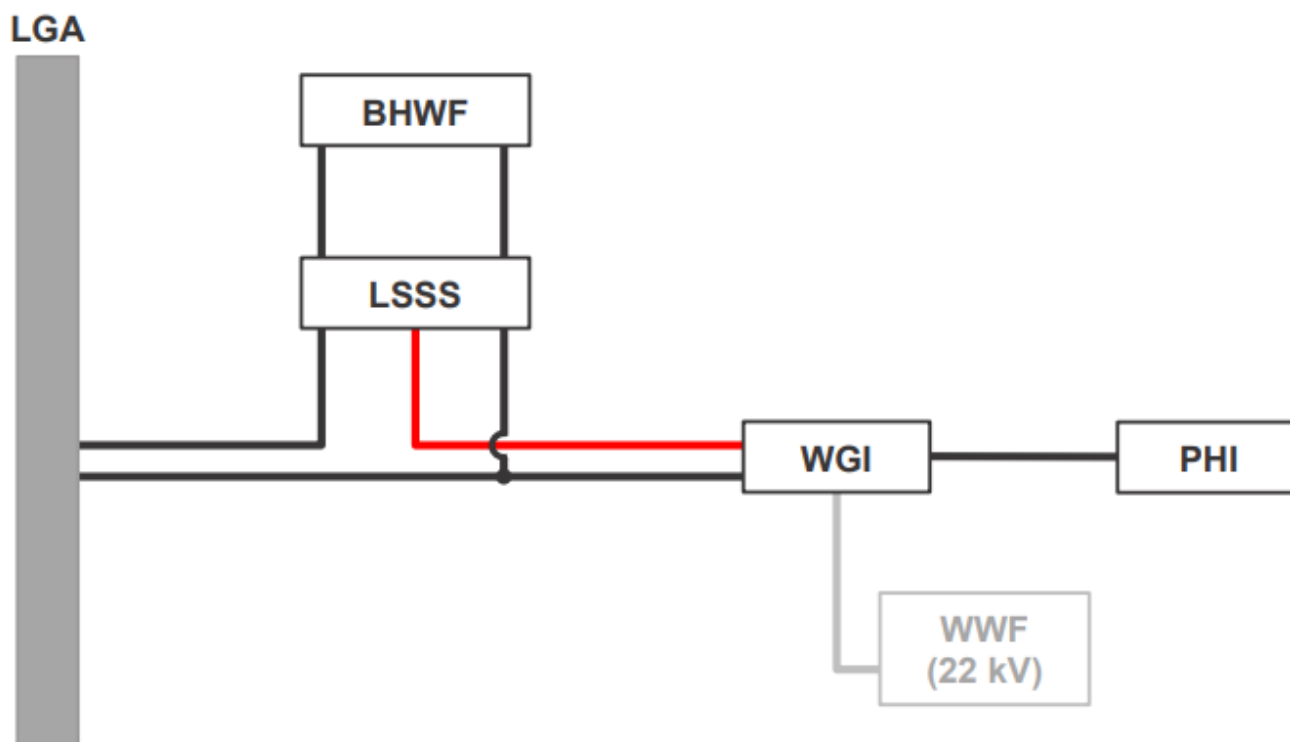

**Figure 8: LGA-WGI-PHI 66 kV Loop**

Other options considered by AusNet included:

- Re-conductor up to 27 kilometres of existing 6/1/.186 ACSR conductor to 19/4.75 AAC conductor in the LSSS – WGI and LGA – LSSS/WGI 66 kV lines.
- Contract network support via embedded generation connected to WGI or PHI to reduce demand during risk periods.
- Contract for network support via demand management to reduce demand during risk periods.

### 6.1.3. MWTS-LGA-FTR-WGI-PHI 66 kV loop

The Morwell Terminal Station (MWTS) to Leongatha (LGA) to Foster (FTR) to Wonthaggi (WGI) to Phillip Island (PHI) 66 kV network supplies over 54,900 customers via the four zone substations at Leongatha, Foster, Wonthaggi and Phillip Island. This 66 kV loop has energy at risk over the peak tourism season of Christmas and early January. An outage of either of the MWTS-LGA No. 1 or the No. 3 66 kV line will result in thermal overload of the MWTS-LGA No. 2 66 kV line, requiring load shedding if loading exceeds 92.3 MVA. Maximum coincident demand in summer is expected to reach 124.5 MVA in December 2025 increasing to 130.6 MVA in December 2029 under PoE10 conditions. The 106 MW Bald Hills Wind Farm (BHWF), connected into this 66 kV loop in 2015, generates sufficient output to eliminate the risk of overload under single contingency, and for most of the time. The Wonthaggi Wind Farm (WWF) also serves to mitigate this energy-at-risk when it is operating.

As mentioned in section 6.1.2, we have contracted a Non-Network solution (PICESS) that will also help to reduce the load at risk on this loop.

Figure 9 shows the single line diagram of this loop along with the constrained line segment (coloured in red) under single order contingency.

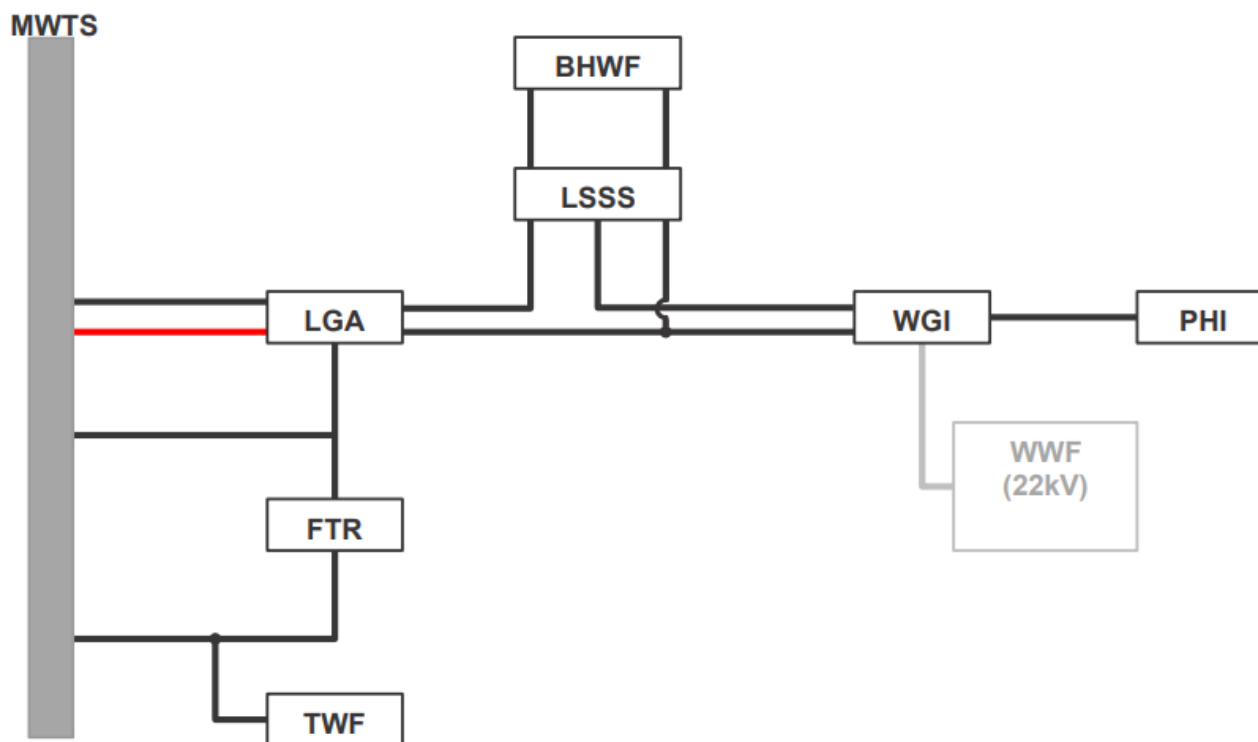

**Figure 9: MWTS-LGA-FTR-WGI-PHI 66 kV Loop**

AusNet has been examining options to address this summer constraint and the following are being considered:

- Re-conductor up to 22 kilometres of existing 6/1/.186 ACSR conductor to 19/4.75 AAC conductor in the MWTS-LGA No. 2 66 kV line.
- Contract network support via embedded generation connected to LGA, WGI or PHI, to offset demand during risk periods.
- Contract for network support via demand management, to reduce demand during supply risk periods.

As mentioned in Section 8 AusNet has also recently published a RIT-D in which the preferred option involves the upgrade of the MWTS-LGA No.2 and No.3 66 kV lines to 37/3.75 AAC conductor. Should this project proceed, the summer constraint described above will be significantly reduced.

### 6.1.4. MWTS-TGN-SLE-MFA-BDSS-BDL-NLA-CNR 66 kV loop

The East Gippsland 66kV sub-transmission loop, the longest in AusNet's system, supplies over 71,400 customers and is geographically isolated, which limits capacity transfers and increases susceptibility to voltage stability issues. Originating from the Morwell Terminal Station (MWTS), it comprises six zone substations: Traralgon (TGN), Sale (SLE), Maffra (MFA), Bairnsdale (BDL), Newmerella (NLA), and Cann River (CNR). Demand is rising due to customer growth, home gas electrification, and EV adoption, with coincidental loading expected to exceed the loop's 144 MVA "N" capacity by summer (December-February) 2026/27 under Probability of Exceedance (POE)50 condition and surpass the 162 MVA voltage collapse limit by summer 2025/2026 under POE10. Under worst-case N-1 conditions (MWTS-SLE outage), the loop's 86.3 MVA thermal limit would be exceeded under summer POE50. With no remedial action, significant load shedding may be required during the peak demand period to prevent voltage collapse and thermal overload. If only the currently committed generator connections proceed as planned, the system is projected to experience unserved energy with an undiscounted total value of approximately \$870.2 million (real \$2024) over the 30-year assessment period. However, there is a considerable uncertainty regarding the actual commissioning of these generators, primarily due to potential network constraints—particularly the need for system strength upgrades.

If any of the committed generators were delayed or cancelled, the impact on reliability could be substantial in the absence of remedial action.

AusNet initiated this RIT-D by publishing an [Options Screening Report \(OSR\)](#) in February 2025 and [Draft Project Assessment Report \(DPAR\)](#) in November 2025. At the time of publishing the OSR, the analysis was based solely on demand forecasts. To enhance the accuracy of the DPAR and better reflect future operating conditions, AusNet considered one anticipated and one committed generation projects in this sub-transmission loop in the modelling and analysis of this DPAR.

### 6.1.5. SMTS-DRN-KLK-MDI-RUBA-YEA-SMR-KMS 66 kV loop

The proposed Beveridge Zone Substation (BVE) detailed in Section 9.15 is planned to be connected via a cut-in to the adjacent 66 kV SMTS–KMS line (currently rated at 33.72 MVA), as shown in Figure 10 Figure 10.

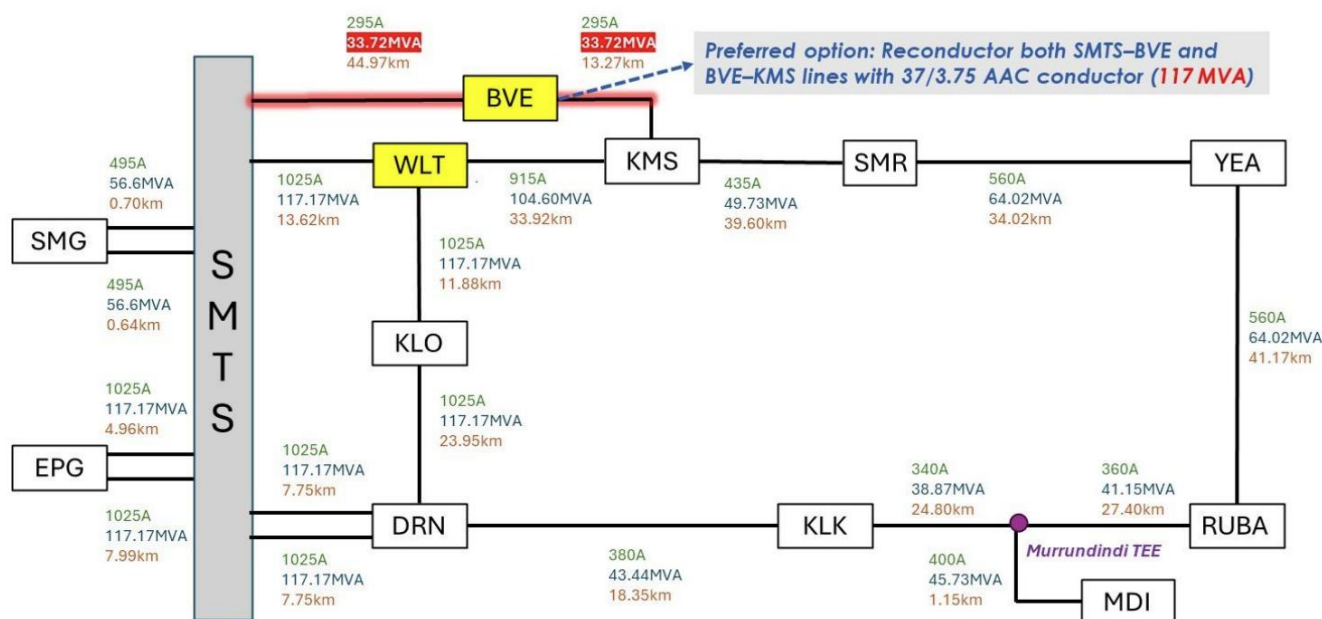

Figure 10: Sub-transmission network with BE connection

Due to this limited capacity, the SMTS–BVE segment is expected to become overloaded by 2026/27 summer (December-February), based on the PoE10 forecast, once the new BVE load is added. This would result in extremely high Expected Unserved Energy (EUE, up to \$45.8m in FY31) and significant reduction in network reliability.

To mitigate this risk, the following sub-transmission upgrade options are being considered.

- Reconductor SMTS–BVE line with 37/3.75 AAC conductor (117 MVA).
- Reconductor SMTS–BVE line with 19/4.75 AAC conductor (104 MVA).
- Reconductor both SMTS–BVE and BVE–KMS lines with 37/3.75 AAC conductor (117 MVA) – Preferred option.
- Construct a new BVE–BVEtee line (tee-out from WLT–KMS line) with 37/3.75 AAC conductor (117 MVA).
- Sub-option 5: Combination of Option 1 and Option 4.

### 6.1.6. TTS-WT-NEL-NH 66 kV loop

The Thomastown Terminal Station (TTS) to Watsonia (WT) to North Heidelberg (NH) to TTS 66 kV loop supplies approximately 45,000 customers (including around 39,650 AusNet customers) via the two zone substations at Watsonia and North Heidelberg. The NEL and NH zone substation is owned by Jemena. The NEL ZSS is for North East link for tunnel boring. The NH 66 kV loop has energy at risk over the summer period from December to March inclusive. Both the TTS–WT (line owned by AusNet) and TTS–NH (line owned by Jemena) 66 kV lines have a rating of 1,025 amps (117.2 MVA) in summer. The maximum coincident demand is forecast to reach 132.7 MVA in summer 2025/26, growing slowly to 136.4 MVA by summer 2029/30 under PoE10 conditions. Figure 11 shows the single line diagram of this loop along with the constrained line segments (coloured in red) under single order contingency.

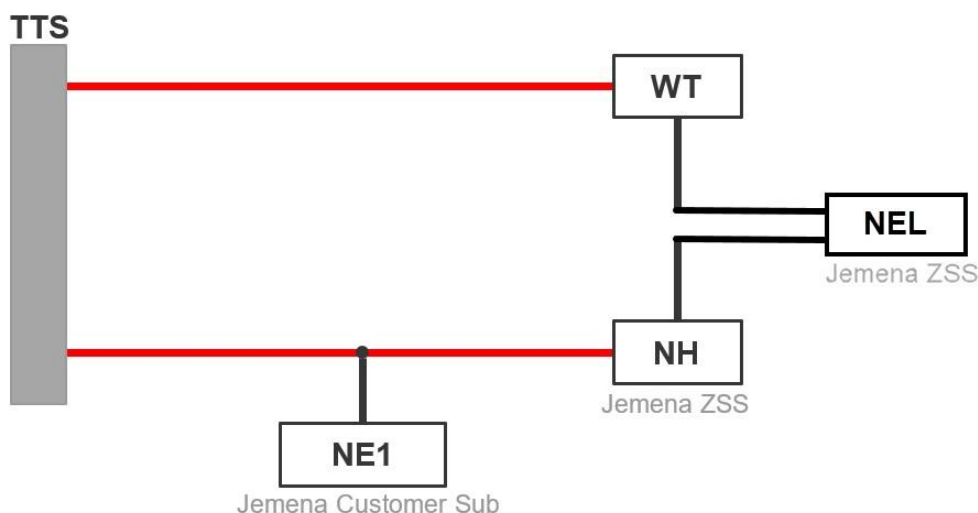

**Figure 11: TTS-WT-NEL-NH 66 kV Loop**

A contingency plan has been developed to transfer load away via 22 kV links to the adjacent zone substations including Jemena zone substations.

### 6.1.6. MWTS-YPS-MOE-WGL-MWTS

The Morwell Terminal Station (MWTS) to Yallourn Power Station (YPS) to Moe (MOE) to Warragul (WGL) 66 kV loop supplies approximately 43,000 customers. This 66 kV loop has energy at risk over the summer period from December to March. The worst-case outage is the loss of the YPS-WGL No.1 66 kV line where loading on the YPS-WGL/MOE 66 kV line between YPS and the tee point will exceed its rating at maximum demand. Figure 12 shows the single line diagram of this loop, and the single order contingency constrained line segment (coloured in red).

From a thermal capacity perspective, the loop should not be loaded above its secure system normal planning limit of 117 MVA in summer and 151 MVA in winter. Exceeding these limits leads to dangerous overloading of the 66kV lines beyond their normal capacity. Due to conductor thermal inertia characteristics, loading 66 kV lines at their normal rating does not allow network controllers sufficient time to reduce load to within asset ratings and can, therefore, result in irreversible conductor damage, cascade tripping of network elements and safety risks if the lines touch the ground due to sagging.

Additionally, the supply to the West Gippsland region is limited under network outage conditions by the thermal capacity of key 66 kV lines. Without manual switching by System Operations, there would be significant values of load at risk (L@R) today on YPS-MOTEE2, MOTEE2-WGL, MOTEE1-MOE and MWTS-MOE lines under single contingency event (N-1).

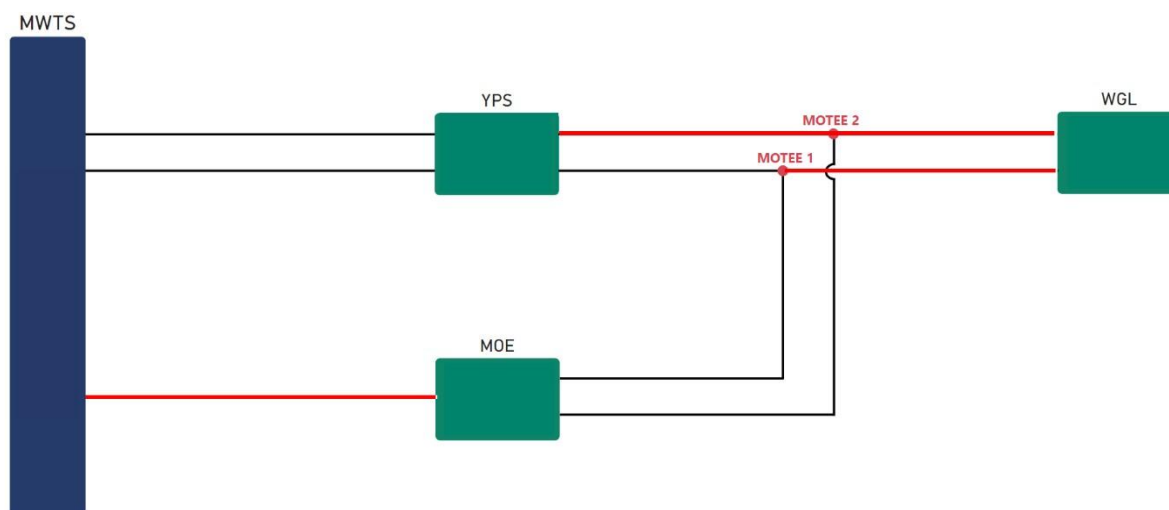

**Figure 12: MWTS-YPS-MOE-WGL 66 kV Loop**

AusNet is currently examining options to address the thermal constraint in case of higher-than-expected POE 10 load forecasts as experienced in previous years. Options being examined are:

- Reconductor the constrained 66kV lines.
- Contract network support via embedded generation connected to WGL or MOE, to offset demand during risk periods.
- Contract for network support via demand management, to reduce demand during supply risk periods.

### 6.1.7. Radial 66 kV lines

AusNet has ten zone substations, including Barnawartha (BWA), Cann River (CNR), Clover Flat (CF), Lang Lang (LLG), Mansfield (MSD), Merrijig (MJG), Mount Beauty (MBY), Newmerella (NLA), Phillip Island (PHI) and Rowville (RVE), which are supplied via single radial 66 kV lines. All of these lines have sufficient capacity over the next five years to supply the forecast demand, however all customers supplied from these zone substations face outages whenever the 66 kV supply line has an outage. Reinforcing these radial 66 kV networks with the construction of a second 66 kV line depends on the reliability performance of the existing radial 66 kV line, and the resultant expected unserved energy. In each of the ten cases, AusNet planning criteria shows that it is not currently economic to duplicate the 66 kV line. While 66 kV line duplication is not economic, AusNet is open to network support and other innovative options to mitigate the supply risks.

To support the NLA and CNR radial 66 kV network, AusNet has installed a battery energy storage system known as the Mallacoota Area Grid Storage (MAGS). The heart of MAGS is a lithium-ion battery system with a total storage capacity of 1 MW / 1 MWh. The MAGS battery is charged from the grid and will feed power back into the grid during local outages, in parallel with its 1 MW diesel generator. The facility is located at the East Gippsland Water treatment plant, just outside the Mallacoota township.

## 6.2. Zone substations import limitations

As per clause 5.13.3 of the NER further details can be found in the Distribution System Limitations Report.

This section presents the zone substations that are carrying, or are forecast to carry, significant service level risk under N-1 in the five-year forward planning period. This service level risk is also quantified alongside commentary outlining the primary drivers of the identified risk.

In some cases, the load transfer capacity is sufficient to cover the N-1 supply risk. However, the service level risk and supply risk cost also consider and quantifies other risk factors such as safety, collateral damage and reactive replacement costs.

Where AusNet considers it economic to do so, network development plans are outlined in Section 9 of this DAPR.

Further information can be found in:

- Rosetta portal (<https://dapr.ausnetservices.com.au/>)
- System Limitations Report

## 6.3. Transmission connection asset export limitations

Details regarding identified export limitations for transmission connection assets, together with the associated analysis, are presented in the TCPR.

## 6.4. Sub-transmission line export limitations

Table 6 presents the estimated magnitude of generation at risk of curtailment under PoE10 conditions, limited to sub-transmission loops that are currently exposed to energy risk. It is to be noted that the limitations are based on the sub transmission loop constraints only, without considering the limitations of connections assets at Terminal Stations. If the Terminal Station connection assets are considered the below curtailments may be higher for certain sub-transmission loops.

**Table 6: Estimated generation at risk on sub-transmission loops with export limitations**

Sub-T loop	Generation at Risk (MW) - N-1 condition				
	10%PoE				
	2026	2027	2028	2029	2030
MWTS-LGA-FTR-TWF-WGI-PHI	69.8	62.9	66.3	68.6	70.5
SMTS-KLO-KMS-DRN-SMR-KLK-MDI-RUBA	23.1	34.1	42.4	50.1	55.4

AusNet is currently investigating a range of options to alleviate forecast export limitations on our sub-transmission loops including (among others):

- Option 1: Review opportunities to reduce upstream terminal station float voltages;
- Option 2: Introduce LDC settings at upstream terminal stations;
- Option 3: Non-network options including generation curtailment support, demand response and/or reactive power network support;
- Option 4: Installation of reactors at the upstream terminal station to increase the available tapping range of power transformers at minimum demand
- Option 5: Network reconfigurations and augmentations;
- Option 6: Engage with AEMO for opportunities to reduce transmission voltages at minimum demand;
- Option 7: Explore opportunities to change the terminal station power transformer tap changer specification to include buck taps; and
- Option 8: Engage with AEMO to adapt the existing switching control system for capacitor banks at terminal stations, to consider power transformers' tap position in its switching decision.

AusNet will continue to monitor the declining minimum demand levels on these sub-transmission loops and explore the feasibility of specific options to alleviate these forecast export limitations on a case-by-case basis.

## 6.5. Zone substation export limitations

This section discusses identified zone substation export limitations. It assesses the limitation, its impact and, where possible, suggests potential solutions. Some minor limitations that exist under contingency conditions, but where there is negligible generation at risk, are not discussed in detail in this section.

Table 7 shows the estimated magnitude of generation at risk of curtailment for 10% PoE conditions, for each zone substation that has identified export limitations.

**Table 7: Estimated generation at risk on zone substations with export limitations**

Zone Substation	Generation at Risk (MW)
	10%POE

	2026	2027	2028	2029	2030
BDL	9.7	10.8	11.6	12.1	13.1
BGE	0.5	1.1	1.7	1.7	2.3
BN	4.4	5.0	5.7	6.2	6.6
BRT	3.2	3.5	3.7	4.0	4.0
BWA	4.3	4.4	4.5	4.5	4.5
BWN	3.7	4.3	4.8	5.2	5.4
BWR	1.9	2.8	3.7	4.0	4.4
CF	0.3	0.3	0.3	0.3	0.3
CLN	17.9	26.7	33.6	39.0	43.7
CNR	0.6	0.7	0.8	0.8	0.9
CPK	0.0	0.8	1.9	2.8	3.2
CRE	0.0	0.9	0.0	0.0	0.0
DRN	14.5	17.0	18.9	19.9	21.8
ELM	0.0	0.8	2.2	3.9	3.8
EPG	12.8	15.8	17.9	19.4	20.2
FGY	10.3	11.5	12.0	12.8	12.9
FTR	5.0	4.5	5.0	4.9	5.1
HPK	4.6	7.3	9.2	10.1	11.2
KLK	2.2	2.5	2.6	2.7	2.8
KLO	9.0	16.1	14.6	20.7	24.9
KMS	5.2	5.4	5.4	5.5	5.7
LDL	1.3	2.3	3.0	3.4	3.3
LGA	4.6	5.3	5.9	5.8	6.0
LLG	0.5	1.1	1.2	1.5	1.7
LYD	4.0	4.7	5.0	5.4	5.7
MBY	1.9	2.0	2.2	2.2	2.3

MDI	0.0	0.0	0.0	0.0	0.0
MFA	4.7	5.3	5.5	5.5	5.8
MJG	0.2	0.2	0.2	0.2	0.2
MOE	11.2	10.1	10.8	10.7	11.1
MSD	6.2	7.0	7.4	7.9	8.0
MWL	4.0	4.8	5.4	5.9	6.0
MYT	5.3	5.6	6.1	6.3	6.5
NLA	2.4	2.7	2.9	3.0	3.0
OFR	2.9	1.5	2.3	2.6	4.3
RUBA	6.0	6.3	6.5	6.8	6.9
RVE	5.1	5.8	6.3	6.6	7.1
SMG	1.4	2.1	0.0	0.0	0.0
SMR	4.9	5.7	6.2	6.5	6.3
TGN	2.8	1.5	2.3	3.4	3.7
TT	7.1	7.9	8.1	8.3	8.3
WGI	20.9	22.6	24.0	24.8	25.3
WGL	3.2	2.5	0.0	0.0	0.0
WN	12.4	13.7	14.8	16.2	16.2
WO	3.7	4.6	5.1	5.4	5.9
WOTS	14.5	16.2	17.5	18.5	19.1
WT	4.4	5.7	5.4	6.1	6.0
WYK	2.7	3.8	4.7	4.6	5.5

AusNet is currently investigating a range of options to alleviate forecast export limitations on our zone substations including (among others):

- Option 1: Review opportunities to reduce zone station float voltages;
- Option 2: Introduce LDC settings at zone substations;
- Option 3: Non-network options including generation curtailment support, demand response and/or reactive power network support;
- Option 4: Installation of reactors at the zone substation to increase the available tapping range of power transformers at minimum demand;
- Option 5: Network reconfigurations and augmentations;

- Option 6: Application of Dynamic Voltage Management capability at the zone substation (an enhanced voltage control system informed by a near-real time AMI voltage data feedback loop);
- Option 7: Explore opportunities to change the zone substation power transformer tap changer specification to increase the number of buck taps;
- Option 8: Optimise existing capacitor bank switching settings at zone substations; and
- Option 9: Introduce a power transformer tap position control logic interlock, applied to capacitor bank switching relays at zone substations.

AusNet will continue to monitor the declining minimum demand levels on these zone substations and explore the feasibility of specific options to alleviate these forecast export limitations on a case-by-case basis.

# 7. System Limitations for Primary Distribution Feeders

## 7.1. Primary distribution feeders import limitations

This section outlines the primary distribution feeders that are currently or are forecast to be import limited (i.e., overloaded) within the next two years. This section addresses the requirements of the NER schedule 5.8 (d). The name of the feeder indicates its location based on the zone substation, such as BN11 from BN zone substation.

Distribution feeders that are overloaded or are forecast to become overloaded in the next two years are presented in **Error! Reference source not found.**, along with the extent of the forecast overload and the number of customers that the feeder supplies.

Table 9 provides details of the estimated reduction in forecast load that would be required to eliminate a forecast feeder overload for a period of 12 months. The table covers a summary of the location of relevant connection points at which the estimated reduction in forecast load would defer the overload and the estimated reduction in forecast load in MW needed to defer the forecast system limitation. The estimate of the year in which the overload is forecast to occur is also provided.

**Table 8: Import limited (Overloaded) feeders for 50% and 10% probability of exceedance conditions**

Feeder	Number of Customers	Summer Import Rating (A)	Maximum Load at Risk (A)					
			50% PoE			10% PoE		
			2025/26	2026/27	2027/28	2025/26	2026/27	2027/28
BN11	4783	285	43	45	43	71	73	73
BN24	1125	315	32	33	30	53	53	50
BWN12	1329	365	-	-	-	8	8	7
BWR22	1113	270	43	47	60	64	70	79
CLN11	12854	375	127	196	269	249	334	407
CLN12	6612	335	17	16	13	38	36	33
CLN13	4884	344	20	39	59	84	105	127
CLN14	6308	325	-	2	10	39	51	59
CLN21	6104	358	-	-	-	1	8	11
CLN22	3898	375	31	45	55	62	82	95
CLN23	5393	323	-	-	-	20	35	58
CRE21	5422	375	-	-	-	-	32	34
CRE23	3326	360	61	60	56	87	86	82
CRE31	6551	375	-	-	5	43	57	66
CRE33	4991	335	7	19	31	52	65	78
DRN11	6079	326	-	-	-	20	23	25
ELM21	2476	258	-	-	-	27	27	27
EPG12	7339	340	3	16	26	68	82	93

EPG13	8211	365	70	223	254	131	286	320
EPG21	276	387	-	-	58	-	40	164
EPG23	1732	360	-	-	18	-	-	48
EPG31	3241	250	-	-	-	34	34	33
EPG32	4080	285	-	-	-	-	8	18
EPG33	326	387	-	-	-	-	29	67
EPG35	344	315	84	80	96	106	102	122
HPK22	4837	311	-	-	-	9	13	14
HPK23	3636	330	-	-	-	7	8	7
HPK24	1596	316	-	-	-	36	36	37
KLO14	12961	360	153	303	409	260	423	535
KLO24	8994	360	186	234	274	256	313	357
KMS12	4946	375	-	-	-	-	2	10
MOE23	2471	180	-	-	-	22	24	24
MSD4	3111	230	-	-	-	11	13	13
OFR11	6334	360	-	-	-	-	-	10
OFR14	3767	360	-	78	137	30	132	191
OFR21	4636	375	-	-	-	16	37	40
PHM21	2145	335	201	290	289	220	310	309
PHM22	1743	375	10	93	115	32	112	125
PHM32	3479	345	17	-	-	69	41	40
RWT21	610	250	-	-	-	-	-	7
SLE31	3866	297	-	79	78	23	118	115
SMR14	2467	157	2	2	2	13	15	14
SMR24	3800	350	13	16	15	47	51	50
TGN11	4475	280	-	-	-	-	-	1
TGN31	2284	180	-	-	-	-	2	5
WGL13	4294	325	24	89	106	53	119	134
WGL15	3095	285	-	-	-	10	12	12
WGL21	5317	365	27	43	45	69	86	89
WN2	3967	275	-	-	-	24	27	27
WN4	2884	211	-	7	7	13	34	31
WN6	4632	285	-	-	-	8	9	9
WOTS11	3983	290	-	-	-	8	17	30
WOTS25	3888	260	15	24	31	58	68	78

**Table 9: Details of load reduction required to defer limitation by one year**

Feeder	Forecast Overload Timing	Load reduction required for 12-month deferral (MW)	Comments
BN11	December, 2025	2.8	Feeder can be risk managed until 2025. Non-network solutions will be considered.
BN24	December, 2025	2.1	Feeder can be risk managed until 2025. Non-network solutions will be considered.
BWN12	December, 2025	0.4	Feeder can be risk managed until 2025. Non-network solutions will be considered.
BWR22	December, 2025	2.5	Feeder can be risk managed until 2025. Non-network solutions will be considered.
CLN11	December, 2025	9.5	New CLN32 & CLN33 Feeder proposed to address this feeder (refer to section 9). Feeder can be risk managed until 2025.
CLN12	December, 2025	1.5	Non-network solutions will be considered.
CLN13	December, 2025	3.3	New CLN32 & CLN33 Feeder proposed to address this feeder (refer to section 9). Feeder can be risk managed until 2025.
CLN14	December, 2025	1.5	Non-network solutions will be considered.
CLN21	December, 2025	0.1	Feeder can be risk managed until 2025. Non-network solutions will be considered.
CLN22	December, 2025	2.4	Feeder can be risk managed until 2025. Non-network solutions will be considered.
CLN23	December, 2025	0.8	Feeder can be risk managed until 2025. Non-network solutions will be considered.
CRE21	December, 2026	1.3	New CRE34 feeder proposed to address this feeder (refer to section 9).
CRE23	December, 2025	3.4	Feeder can be risk managed until 2025. Non-network solutions will be considered.
CRE31	December, 2025	1.7	Feeder can be risk managed until 2025. Non-network solutions will be considered.
CRE33	December, 2025	2	New CLN32 & CLN33 Feeder proposed to address this feeder (refer to section 9).
DRN11	December, 2025	0.8	WLT ZSS proposed to address this feeder (refer to section 9). Feeder can be risk managed until 2025.
ELM21	December, 2025	1.1	Non-network solutions will be considered.
EPG12	December, 2025	2.6	WLT ZSS proposed to address this feeder (refer to section 9).

EPG13	December, 2025	5	WLT ZSS proposed to address this feeder (refer to section 9).
EPG21	December, 2026	1.6	Feeder can be risk managed until 2026. Non-network solutions will be considered.
EPG23	December, 2027	1.9	WLT ZSS proposed to address this feeder (refer to section 9).
EPG31	December, 2025	1.3	Feeder can be risk managed until 2025. Non-network solutions will be considered.
EPG32	December, 2026	0.4	WLT ZSS proposed to address this feeder (refer to section 9).
EPG33	December, 2026	1.2	Feeder can be risk managed until 2026. Non-network solutions will be considered.
EPG35	December, 2025	4.1	Feeder can be risk managed until 2025. Non-network solutions will be considered.
HPK22	December, 2025	0.4	Feeder can be risk managed until 2025. Non-network solutions will be considered.
HPK23	December, 2025	0.3	Feeder can be risk managed until 2025. Non-network solutions will be considered.
HPK24	December, 2025	1.4	Feeder can be risk managed until 2025. Non-network solutions will be considered.
KLO14	December, 2025	10	BVE ZSS proposed to address this feeder (refer to section 9).
KLO24	December, 2025	9.8	BVE ZSS proposed to address this feeder (refer to section 9).
KMS12	December, 2026	0.1	Feeder can be risk managed until 2026. Non-network solutions will be considered.
MOE23	December, 2025	0.9	Feeder can be risk managed until 2025. Non-network solutions will be considered.
MSD4	December, 2025	0.5	Feeder can be risk managed until 2025. Non-network solutions will be considered.
OFR11	December, 2027	0.4	Feeder can be risk managed until 2027. Non-network solutions will be considered.
OFR14	December, 2025	1.2	Feeder can be risk managed until 2025. Non-network solutions will be considered.
OFR21	December, 2025	0.7	Feeder can be risk managed until 2025. Non-network solutions will be considered.
PHM21	December, 2025	8.4	Feeder can be risk managed until 2025. Non-network solutions will be considered.
PHM22	December, 2025	1.3	Feeder can be risk managed until 2025. Non-network solutions will be considered.
PHM32	December, 2025	2.7	Feeder can be risk managed until 2025. Non-network solutions will be considered.

RWT21	December, 2027	0.3	Feeder can be risk managed until 2027. Non-network solutions will be considered.
SLE31	December, 2025	0.9	Feeder can be risk managed until 2025. Non-network solutions will be considered.
SMR14	December, 2025	0.5	Feeder can be risk managed until 2025. Non-network solutions will be considered.
SMR24	December, 2025	1.8	Feeder can be risk managed until 2025. Non-network solutions will be considered.
TGN11	December, 2027	0.1	Feeder can be risk managed until 2027. Non-network solutions will be considered.
TGN31	December, 2026	0.1	Feeder can be risk managed until 2026. Non-network solutions will be considered.
WGL13	December, 2025	2.1	Feeder can be risk managed until 2025. Non-network solutions will be considered.
WGL15	December, 2025	0.4	Feeder can be risk managed until 2025. Non-network solutions will be considered.
WGL21	December, 2025	2.7	Feeder can be risk managed until 2025. Non-network solutions will be considered.
WN2	December, 2025	1	Feeder can be risk managed until 2025. Non-network solutions will be considered.
WN4	December, 2025	0.5	Feeder can be risk managed until 2025. Non-network solutions will be considered.
WN6	December, 2025	0.4	Feeder can be risk managed until 2025. Non-network solutions will be considered.
WOTS11	December, 2025	0.4	Feeder can be risk managed until 2025. Non-network solutions will be considered.
WOTS25	December, 2025	2.3	Feeder can be risk managed until 2025. Non-network solutions will be considered.

## 7.2. Primary distribution feeder export limitations

This section outlines the primary distribution feeders that are currently or are forecast to be export limited within the next two years. This section addresses the requirements of the NER schedule 5.8 (d1).

Distribution feeders that are currently or forecast to be export limited in the next two years are presented in Table 10, along with the extent of the generation at risk of curtailment and the number of customers the feeder supplies.

**Table 10: Export limited feeders for 50% and 10% probability of exceedance conditions**

Primary Distribution Feeder	No. Cust.	Export Rating (MW)	Generation at Risk (MW)					
			10% POE			50% POE		
			2026	2027	2028	2026	2027	2028
BDL31	3811	0.0	2.5	2.8	3.0	2.5	2.7	2.9
BDL32	3730	0.0	2.6	2.9	3.1	2.4	2.7	2.8
BDL33	1266	0.0	0.9	1.0	1.1	0.5	0.6	0.7
BDL34	5447	0.0	5.5	6.0	6.3	5.3	5.8	6.1
BDL41	4263	0.0	2.1	2.3	2.6	2.0	2.3	2.5
BDL44	2768	0.0	2.7	2.8	2.9	2.3	2.4	2.5
BN11	4785	0.0	2.6	2.9	3.0	2.1	2.4	2.4
BN22	3614	0.0	2.6	2.9	3.0	2.2	2.4	2.6
BN23	2483	0.0	2.4	2.6	2.8	2.2	2.4	2.6
BRT22	1722	0.0	1.5	1.7	1.8	1.3	1.4	1.6
BWA22	1520	0.0	6.5	6.6	6.7	6.1	6.2	6.3
BWA23	458	0.0	0.8	0.8	0.8	0.4	0.4	0.4
CF1	77	-2.4	0.4	0.4	0.4	-1.2	-1.1	-1.1
CLN11	12300	-1.6	16.7	18.9	20.5	16.2	18.2	20.0
CLN13	5314	-11.9	7.5	8.0	8.5	4.3	4.7	5.1
CLN23	1366	-12.3	2.1	3.1	3.9	0.7	1.7	2.5
CPK12	3155	-2.3	1.1	1.7	2.2	0.9	1.4	1.8
CRE33	5004	-0.2	6.1	6.9	7.8	5.1	6.0	6.7
DRN22	3997	-2.7	12.4	13.0	13.4	9.1	9.2	9.3
ELM26	3224	-1.2	1.7	2.1	2.6	1.6	2.0	2.4

ELM32	2804	-2.2	0.0	0.4	0.7	-0.4	0.0	0.3
EPG13	8661	-0.1	18.3	20.5	22.6	16.8	19.1	21.2
EPG32	3436	-8.0	9.0	9.6	10.1	4.7	5.3	5.8
FTR21	2481	0.0	1.6	1.8	2.0	1.5	1.7	1.8
FTR22	1443	-0.7	0.5	0.6	0.7	0.5	0.6	0.7
FTR23	3630	0.0	2.3	2.6	2.8	1.9	2.1	2.4
HPK21	5649	-10.4	5.3	5.8	6.4	4.3	5.0	5.5
KLO14	8890	0.0	22.8	28.0	24.8	20.9	25.6	22.4
KLO24	8887	-6.2	7.8	10.1	12.2	3.3	5.3	7.6
KMS11	2210	0.0	0.7	0.5	0.2	0.5	0.3	0.0
KMS12	4965	0.0	2.7	3.1	3.4	2.4	2.8	3.2
LDL13	4132	-0.2	4.4	4.8	5.3	3.6	4.1	4.5
LDL14	2359	-0.8	0.7	0.9	1.1	0.4	0.5	0.7
LDL23	4894	-2.6	0.4	0.8	1.3	-0.2	0.3	0.6
LGA11	1731	0.0	0.9	1.0	1.1	0.8	0.9	1.0
LGA12	1062	0.0	2.3	2.4	2.4	1.1	1.2	1.3
LGA14	1734	0.0	1.7	1.8	2.0	1.5	1.7	1.8
LGA21	1974	-1.1	0.8	1.0	1.1	0.7	0.9	1.1
LLG14	2861	0.0	1.8	2.0	2.1	1.6	1.8	1.9
MBY11	1212	-1.1	0.2	0.3	0.4	0.1	0.2	0.3
MDG1	750	0.0	0.3	0.3	0.3	0.2	0.2	0.2
MFA21	2892	0.0	2.2	2.4	2.6	1.8	2.0	2.2
MFA22	1621	-2.2	-0.3	-0.2	-0.1	-0.7	-0.7	-0.6
MFA31	2355	-1.3	0.1	0.2	0.2	-0.2	-0.1	0.0
MFA34	1600	0.0	1.0	1.2	1.2	0.9	1.1	1.1
MJG11	1421	0.0	0.7	0.8	0.8	-0.1	0.0	0.0
MOE12	1124	0.0	1.3	1.4	1.5	1.1	1.3	1.4
MOE13	769	-2.9	5.6	3.6	3.7	4.6	2.6	2.6
MOE15	1928	0.0	1.5	1.6	1.7	1.3	1.4	1.5
MOE21	2893	0.0	1.2	1.4	1.5	1.0	1.2	1.3

MOE23	2464	0.0	1.1	1.2	1.3	0.9	1.0	1.0
MSD1	2258	0.0	1.6	1.9	2.1	1.6	1.8	2.0
MSD2	1734	0.0	1.5	1.7	1.8	1.3	1.5	1.6
MSD4	3078	0.0	3.1	3.6	3.9	2.6	3.0	3.3
MWL11	1432	-1.1	0.5	0.6	0.7	0.3	0.4	0.5
MYT12	3323	0.0	3.0	3.2	3.5	2.5	2.9	3.1
MYT21	1896	0.0	1.6	1.8	1.9	1.3	1.5	1.6
OFR11	5538	-12.3	4.5	6.0	7.2	2.8	4.3	5.6
PHI12	5130	0.0	7.9	8.3	8.6	7.5	7.9	8.3
PHI13	4873	0.0	2.4	2.6	2.9	2.0	2.2	2.6
PHM33	1349	-0.9	4.4	4.5	4.8	4.0	4.2	4.3
RUBA12	2769	0.0	1.7	1.9	2.1	1.5	1.7	1.9
RUBA22	1367	0.0	0.8	0.9	1.0	0.7	0.8	0.9
RWN31	2434	-1.3	0.5	0.8	1.1	0.3	0.6	0.8
RWT32	4023	-1.3	0.5	0.8	1.2	0.3	0.5	0.7
SFS1	1099	0.0	0.2	0.3	0.3	0.1	0.2	0.3
SMR13	2902	0.0	0.9	1.0	1.2	0.7	0.9	1.1
SMR14	2485	0.0	1.8	2.0	2.2	1.6	1.9	2.0
SMR22	1607	0.0	1.2	1.4	1.6	1.0	1.2	1.4
SMR24	3763	0.0	1.7	2.0	2.4	1.5	1.8	2.2
TGN11	4214	0.0	3.1	3.5	3.8	2.9	3.2	3.5
TGN23	2491	-1.6	0.8	1.0	1.2	0.7	0.9	1.1
TGN31	2336	0.0	9.9	10.2	10.5	6.8	7.1	7.4
TGN41	1922	0.0	1.5	1.6	1.8	1.3	1.4	1.5
TGN43	3978	0.0	1.9	2.2	2.5	1.7	2.0	2.1
TT6	4844	-2.3	0.2	0.6	0.9	-0.1	0.2	0.4
UWY1	1085	0.0	0.5	0.7	0.8	0.4	0.6	0.7
WGI22	3334	0.0	2.7	3.1	3.4	2.7	3.0	3.2
WGI23	2966	0.0	3.4	3.7	4.0	3.3	3.6	3.9
WGI24	3940	0.0	3.0	3.3	3.6	2.9	3.2	3.5

WGI31	3842	0.0	2.7	3.0	3.3	2.6	2.9	3.2
WGI32	4201	-2.1	1.3	1.8	2.1	1.2	1.8	2.0
WGI33	3320	0.0	1.5	1.8	2.0	1.4	1.7	1.9
WGL11	5406	0.0	3.3	3.4	3.7	2.7	2.9	3.2
WGL12	3951	0.0	3.3	3.6	3.9	2.8	3.1	3.4
WGL15	3084	0.0	0.5	0.7	0.9	0.1	0.3	0.5
WGL21	5248	0.0	1.1	1.9	2.3	0.6	1.3	1.8
WGL23	1428	-1.4	0.2	0.3	0.4	0.0	0.1	0.2
WGL24	3909	0.0	1.0	-1.0	-0.9	0.8	-1.2	-1.0
WN2	3960	0.0	4.7	5.1	5.5	4.2	4.6	5.0
WN3	2996	0.0	3.1	3.3	3.7	2.6	2.9	3.2
WN4	2895	0.0	1.8	2.1	2.5	1.4	1.7	2.1
WN5	2477	0.0	3.7	3.9	4.0	3.1	3.3	3.4
WN6	4617	0.0	3.9	4.5	4.9	3.4	4.0	4.4
WO22	4315	0.0	1.9	2.4	2.6	1.3	1.7	2.0
WOTS11	3909	0.0	4.7	5.1	5.4	4.3	4.6	5.0
WOTS12	2172	0.0	1.7	1.9	2.0	1.4	1.5	1.6
WOTS13	2018	0.0	2.2	2.4	2.5	2.0	2.2	2.3
WOTS24	2227	0.0	2.1	2.3	2.6	1.9	2.2	2.4
WOTS25	4074	0.0	6.5	7.3	7.8	6.0	6.5	7.0
WYK23	3954	-0.1	2.3	2.7	3.0	2.2	2.5	2.9
WYK24	3542	-0.8	0.7	0.9	1.2	0.6	0.8	1.1

AusNet is currently investigating a range of options to alleviate forecast export limitations on our primary distribution feeders including (among others):

- Option 1: Introducing LDC settings at the upstream zone substations or in-line feeder voltage regulators;
- Option 2: Non-network options including generation curtailment support, flexible exports, demand response and/or reactive power network support;
- Option 3: Network reconfigurations or augmentations to shorten feeders or split feeders;
- Option 4: Application of Dynamic Voltage Management capability at the upstream zone substation (an enhanced voltage control system informed by a near-real time AMI voltage data feedback loop); and
- Option 5: Optimisation of capacitor bank switching settings on existing in-line feeder shunt capacitor banks.

Table 11 provides details of the estimated reduction in forecast generation that would be required to eliminate a forecast feeder export limitation for a period of 12 months. The table covers a summary of the location of relevant connection points and the estimated reduction in forecast generation in MW needed to defer the forecast system limitation. The estimate of the year in which the limitation is forecast to occur is also provided.

**Table 11: Details of generation reduction required to defer limitation by one year**

Feeder	Forecast Limitation Timing	Generation Reduction Required for 12-month deferral (MW)	Comments
BDL31	December 2025	2.5	Application of Dynamic Voltage Management capability at the upstream zone substation
BDL32	December 2025	2.6	Application of Dynamic Voltage Management capability at the upstream zone substation
BDL33	December 2025	0.9	Application of Dynamic Voltage Management capability at the upstream zone substation
BDL34	December 2025	5.5	Application of Dynamic Voltage Management capability at the upstream zone substation
BDL41	December 2025	2.1	Application of Dynamic Voltage Management capability at the upstream zone substation
BDL44	December 2025	2.7	Application of Dynamic Voltage Management capability at the upstream zone substation
BN11	December 2025	2.6	Introducing LDC settings at the upstream zone substations or in-line feeder voltage regulators
BN22	December 2025	2.6	Introducing LDC settings at the upstream zone substations or in-line feeder voltage regulators

BN23	December 2025	2.4	Introducing LDC settings at the upstream zone substations or in-line feeder voltage regulators
BRT22	December 2025	1.5	Introducing LDC settings at the upstream zone substations or in-line feeder voltage regulators
BWA22	December 2025	6.5	Introducing LDC settings at the upstream zone substations or in-line feeder voltage regulators
BWA23	December 2025	0.8	Introducing LDC settings at the upstream zone substations or in-line feeder voltage regulators
CF1	December 2025	0.4	Introducing LDC settings at the upstream zone substations or in-line feeder voltage regulators
CLN11	December 2025	16.7	Introducing LDC settings at the upstream zone substations or in-line feeder voltage regulators
CLN13	December 2025	7.5	Introducing LDC settings at the upstream zone substations or in-line feeder voltage regulators
CLN23	December 2025	2.1	Introducing LDC settings at the upstream zone substations or in-line feeder voltage regulators
CPK12	December 2025	1.1	Introducing LDC settings at the upstream zone substations or in-line feeder voltage regulators
CRE33	December 2025	6.1	Introducing LDC settings at the upstream zone substations or in-line feeder voltage regulators
DRN22	December 2025	12.4	Introducing LDC settings at the upstream zone substations or in-line feeder voltage regulators
ELM26	December 2025	1.7	Application of Dynamic Voltage Management capability at the upstream zone substation

ELM32	December 2026	0.4	Application of Dynamic Voltage Management capability at the upstream zone substation
EPG13	December 2025	18.3	Introducing LDC settings at the upstream zone substations or in-line feeder voltage regulators
EPG32	December 2025	9	Introducing LDC settings at the upstream zone substations or in-line feeder voltage regulators
FTR21	December 2025	1.6	Introducing LDC settings at the upstream zone substations or in-line feeder voltage regulators
FTR22	December 2025	0.5	Introducing LDC settings at the upstream zone substations or in-line feeder voltage regulators
FTR23	December 2025	2.3	Introducing LDC settings at the upstream zone substations or in-line feeder voltage regulators
HPK21	December 2025	5.3	Application of Dynamic Voltage Management capability at the upstream zone substation
KLO14	December 2025	22.8	Introducing LDC settings at the upstream zone substations or in-line feeder voltage regulators
KLO24	December 2025	7.8	Introducing LDC settings at the upstream zone substations or in-line feeder voltage regulators
KMS11	December 2025	0.7	Introducing LDC settings at the upstream zone substations or in-line feeder voltage regulators
KMS12	December 2025	2.7	Application of Dynamic Voltage Management capability at the upstream zone substation, reactive power network support.

LDL13	December 2025	4.4	Introducing LDC settings at the upstream zone substations or in-line feeder voltage regulators
LDL14	December 2025	0.7	Introducing LDC settings at the upstream zone substations or in-line feeder voltage regulators
LDL23	December 2025	0.4	Introducing LDC settings at the upstream zone substations or in-line feeder voltage regulators
LGA11	December 2025	0.9	Introducing LDC settings at the upstream zone substations or in-line feeder voltage regulators
LGA12	December 2025	2.3	Introducing LDC settings at the upstream zone substations or in-line feeder voltage regulators
LGA14	December 2025	1.7	Introducing LDC settings at the upstream zone substations or in-line feeder voltage regulators
LGA21	December 2025	0.8	Introducing LDC settings at the upstream zone substations or in-line feeder voltage regulators
LLG14	December 2025	1.8	Introducing LDC settings at the upstream zone substations or in-line feeder voltage regulators
MBY11	December 2025	0.2	Introducing LDC settings at the upstream zone substations or in-line feeder voltage regulators
MDG1	December 2025	0.3	Introducing LDC settings at the upstream zone substations or in-line feeder voltage regulators
MFA21	December 2025	2.2	Introducing LDC settings at the upstream zone substations or in-line feeder voltage regulators
MFA22	December 2025	-0.3	Introducing LDC settings at the upstream zone substations or in-line feeder voltage regulators

MFA31	December 2025	0.1	Introducing LDC settings at the upstream zone substations or in-line feeder voltage regulators
MFA34	December 2025	1	Introducing LDC settings at the upstream zone substations or in-line feeder voltage regulators
MJG11	December 2025	0.7	Introducing LDC settings at the upstream zone substations or in-line feeder voltage regulators
MOE12	December 2025	1.3	Introducing LDC settings at the upstream zone substations or in-line feeder voltage regulators
MOE13	December 2025	5.6	Introducing LDC settings at the upstream zone substations or in-line feeder voltage regulators
MOE15	December 2025	1.5	Introducing LDC settings at the upstream zone substations or in-line feeder voltage regulators
MOE21	December 2025	1.2	Introducing LDC settings at the upstream zone substations or in-line feeder voltage regulators
MOE23	December 2025	1.1	Introducing LDC settings at the upstream zone substations or in-line feeder voltage regulators
MSD1	December 2025	1.6	Application of Dynamic Voltage Management capability at the upstream zone substation, reactive power network support.
MSD2	December 2025	1.5	Introducing LDC settings at the upstream zone substations or in-line feeder voltage regulators
MSD4	December 2025	3.1	Application of Dynamic Voltage Management capability at the upstream zone substation, reactive power network support.

MWL11	December 2025	0.5	Introducing LDC settings at the upstream zone substations or in-line feeder voltage regulators
MYT12	December 2025	3	Application of Dynamic Voltage Management capability at the upstream zone substation, reactive power network support.
MYT21	December 2025	1.6	Introducing LDC settings at the upstream zone substations or in-line feeder voltage regulators
OFR11	December 2025	4.5	Introducing LDC settings at the upstream zone substations or in-line feeder voltage regulators
PHI12	December 2025	7.9	Application of Dynamic Voltage Management capability at the upstream zone substation
PHI13	December 2025	2.4	Application of Dynamic Voltage Management capability at the upstream zone substation
PHM33	December 2025	4.4	Introducing LDC settings at the upstream zone substations or in-line feeder voltage regulators
RUBA12	December 2025	1.7	Introducing LDC settings at the upstream zone substations or in-line feeder voltage regulators
RUBA22	December 2025	0.8	Introducing LDC settings at the upstream zone substations or in-line feeder voltage regulators
RWN31	December 2025	0.5	Introducing LDC settings at the upstream zone substations or in-line feeder voltage regulators
RWT32	December 2025	0.5	Introducing LDC settings at the upstream zone substations or in-line feeder voltage regulators

SFS1	December 2025	0.2	Introducing LDC settings at the upstream zone substations or in-line feeder voltage regulators
SMR13	December 2025	0.9	Introducing LDC settings at the upstream zone substations or in-line feeder voltage regulators
SMR14	December 2025	1.8	Introducing LDC settings at the upstream zone substations or in-line feeder voltage regulators
SMR22	December 2025	1.2	Introducing LDC settings at the upstream zone substations or in-line feeder voltage regulators
SMR24	December 2025	1.7	Introducing LDC settings at the upstream zone substations or in-line feeder voltage regulators
TGN11	December 2025	3.1	Introducing LDC settings at the upstream zone substations or in-line feeder voltage regulators
TGN23	December 2025	0.8	Introducing LDC settings at the upstream zone substations or in-line feeder voltage regulators
TGN31	December 2025	9.9	Introducing LDC settings at the upstream zone substations or in-line feeder voltage regulators
TGN41	December 2025	1.5	Introducing LDC settings at the upstream zone substations or in-line feeder voltage regulators
TGN43	December 2025	1.9	Introducing LDC settings at the upstream zone substations or in-line feeder voltage regulators
TT6	December 2025	0.2	Introducing LDC settings at the upstream zone substations or in-line feeder voltage regulators
UWY1	December 2025	0.5	Introducing LDC settings at the upstream zone substations or in-line feeder voltage regulators

WGI22	December 2025	2.7	Application of Dynamic Voltage Management capability at the upstream zone substation
WGI23	December 2025	3.4	Application of Dynamic Voltage Management capability at the upstream zone substation
WGI24	December 2025	3	Application of Dynamic Voltage Management capability at the upstream zone substation
WGI31	December 2025	2.7	Application of Dynamic Voltage Management capability at the upstream zone substation
WGI32	December 2025	1.3	Application of Dynamic Voltage Management capability at the upstream zone substation
WGI33	December 2025	1.5	Application of Dynamic Voltage Management capability at the upstream zone substation
WGL11	December 2025	3.3	Introducing LDC settings at the upstream zone substations or in-line feeder voltage regulators
WGL12	December 2025	3.3	Introducing LDC settings at the upstream zone substations or in-line feeder voltage regulators
WGL15	December 2025	0.5	Introducing LDC settings at the upstream zone substations or in-line feeder voltage regulators
WGL21	December 2025	1.1	Introducing LDC settings at the upstream zone substations or in-line feeder voltage regulators
WGL23	December 2025	0.2	Introducing LDC settings at the upstream zone substations or in-line feeder voltage regulators
WGL24	December 2025	1	Introducing LDC settings at the upstream zone substations or in-line feeder voltage regulators

WN2	December 2025	4.7	Application of Dynamic Voltage Management capability at the upstream zone substation, reactive power network support.
WN3	December 2025	3.1	Application of Dynamic Voltage Management capability at the upstream zone substation, reactive power network support.
WN4	December 2025	1.8	Application of Dynamic Voltage Management capability at the upstream zone substation, reactive power network support.
WN5	December 2025	3.7	Application of Dynamic Voltage Management capability at the upstream zone substation, reactive power network support.
WN6	December 2025	3.9	Application of Dynamic Voltage Management capability at the upstream zone substation, reactive power network support.
WO22	December 2025	1.9	Application of Dynamic Voltage Management capability at the upstream zone substation, reactive power network support.
WOTS11	December 2025	4.7	Application of Dynamic Voltage Management capability at the upstream zone substation, reactive power network support.
WOTS12	December 2025	1.7	Introducing LDC settings at the upstream zone substations or in-line feeder voltage regulators
WOTS13	December 2025	2.2	Application of Dynamic Voltage Management capability at the upstream zone substation, reactive power network support.

WOTS24	December 2025	2.1	Application of Dynamic Voltage Management capability at the upstream zone substation, reactive power network support.
WOTS25	December 2025	6.5	Application of Dynamic Voltage Management capability at the upstream zone substation, reactive power network support.
WYK23	December 2025	2.3	Introducing LDC settings at the upstream zone substations or in-line feeder voltage regulators
WYK24	December 2025	0.7	Introducing LDC settings at the upstream zone substations or in-line feeder voltage regulators

## 8. Regulatory Investment Tests

The regulatory investment test for distribution (RIT-D) is an economic cost-benefit test used to assess and rank potential investments capable of meeting an identified need. The purpose of the RIT-D is to identify the credible option that maximises the present value of net economic benefit to all those who produce, consume and transport electricity in the National Electricity Market (the preferred option).

The RIT-D was initially introduced in March 2013, with Version 55 of NER, with a focus on augmentation expenditure, and was amended in September 2017 to include replacement expenditure planning.

### 8.1. RIT-D projects recently completed or in progress

This section provides details required by schedule 5.8 (e) in covering projects where the RIT-D has been completed in the preceding year or is in progress. Further information is available on the AusNet Services' website:

<https://ausnetservices.com.au/About/Projects-and-Innovation/Regulatory-Investment-Test>

**Table 12: In-Progress RIT's**

Project Name	RIT-D Stage	Identified Need	Credible Options
REFCL Lilydale Zone substation	FPAR	Upgrade REFCL capacity at Lilydale Zone Substation	<ul style="list-style-type: none"> <li>Option 1: Install a third REFCL at LDL.</li> <li>Option 2: Installing an isolation transformer and construct a feeder extension from CYN.</li> </ul>
Secure supply and enable connections: East Gippsland	DPAR	Secure supply and enable connections in the East Gippsland network	<ul style="list-style-type: none"> <li>Option 1: Reconductor MFA-TGN Line</li> <li>Option 2: Construct new Traralgon – Sale (TGN-SLE) 66kV line</li> <li>Option 3: Establish a TGN-SLE/MFA 66kV line</li> <li>Option 4: Construct a 30MW/150MWh Battery Energy Storage System at Bairnsdale Switching Station (BDSS)</li> </ul> <p>Note: All the above options include reconductoring of MWTS-TGN lines</p>
Secure Supply and enable connections: East Cranbourne	FPAR	Secure supply and enable connections in the East Cranbourne network	<ul style="list-style-type: none"> <li>Option 1: Establish a new CBTS-OFR 66kV Line</li> <li>Option 2: Install a new CBTS-PHM line</li> <li>Option 3: Establish a new CBTS-PSH and PSH-PHM 66kV Lines</li> <li>Option 4: Install a new CBTS-LG 66kV line</li> </ul>

			<ul style="list-style-type: none"> <li>Option 5: Install a new 25MW/100MWh battery at Officer zone substation</li> </ul>
KMS 22kV Indoor Switch room replacement	ND	Ensure switch room safety and supply reliability in Kilmore area	<ul style="list-style-type: none"> <li>Option 1: KMS 22kV Switch room Replacement</li> <li>Option 2: No other credible options</li> </ul>
Baw Baw Shire (New 22kV Feeder WGL31 & New Switchboard at WGL ZSS)	OSR	Demand Driven Augmentation	<ul style="list-style-type: none"> <li>Option 1: Construct a new 22kV feeder by utilising the existing WGL11 route</li> <li>Option 2: Construct a new 22kV feeder by utilising the existing WGL24 route</li> <li>Option 3: Non-network or SAPS solutions</li> </ul>
Bairnsdale REFCL Augmentation	DPAR	Upgrade REFCL capacity at Bairnsdale Zone Substation	<ul style="list-style-type: none"> <li>Option 0: 'Do nothing' or Business as Usual.</li> <li>Option 1: Install a third REFCL at BDL and associated works; and</li> <li>Option 2: Install a remote REFCL on BDL44 and an additional remote REFCL in 2029 to reduce capacitive current demand on BDL and provide an additional 22kV bus at BDL in 2033.</li> </ul>
Nagambie (SMR11)	OSR	Demand Driven Augmentation	<ul style="list-style-type: none"> <li>Option 0: Do nothing</li> <li>Option 1: Construct a new 22kV feeder to augment and split SMR24</li> <li>Option 2: Construct a new 22kV express feeder</li> <li>Option 3: SMR24 22kV feeder upgrade to a higher rating</li> <li>Option 4: Non-network or SAPS solutions</li> </ul>
Secure Supply and Enable Connections for Beveridge Area	OSR	Demand Driven Augmentation	<ul style="list-style-type: none"> <li>Option 1: New Beveridge zone substation</li> <li>Option 2: Install a third transformer, 22kV switchboard and feeders at KLO</li> <li>Option 3: Non-network or SAPS solution</li> </ul>

Table 13: Completed RIT-D's (Within the last year)

Project Name	Identified Need	Credible Options	Expected Commissioning Date
Connection Enablement: Morwell South Area	Address sub-transmission constraints to enable more renewable generation connections	<ul style="list-style-type: none"> <li>Option 1: Augment No.2 line with 19/3.25 conductor.</li> <li>Option 2: Augment both lines with 19/4.75 conductor.</li> <li>Option 3 (<b>Preferred Option</b>): Augment both lines with 37/3.75 conductor.</li> <li>Non-network options: Two submissions were considered.</li> </ul>	December 2029
Connection Enablement: Morwell East Area RIT-D	Address sub-transmission constraints to enable more renewable generation connections	<ul style="list-style-type: none"> <li>Option 1: Augment No.1 line with 19/4.75 conductor. (\$4.41 million)</li> <li>Option 2 (<b>Preferred option</b>): Augment both lines with 19/4.75 conductor. (\$7.05 million)</li> <li>Option 3: Augment both lines with 37/3.75 conductor. (\$34.89 million)</li> <li>Non-network options: No submissions were received and therefore not considered.</li> </ul>	October 2026
YPS-MOE-WGL GroundWire Replacement	The ground wire on the YPS-WGL-MOE 66kV line has degraded and is deemed to be in an unsuitable condition and in need of replacement	<ul style="list-style-type: none"> <li>Option 1 (<b>Preferred Option</b>): Replace the GW from tower 1 to tower 97 (\$5.9 million)</li> <li>Option 2: Extend GW replacement from Tower 98 and Tower 116 (\$6.5 million)</li> </ul>	June 2026

## 8.2. Future RIT-D projects

This section provides details required by schedule 5.8 (f) for each identified system limitation for which a DNSP has determined a RIT-D is required and is expected to commence in the next five-year period. In the five-year period, Ausnet expects to commence the RIT-Ds outlined in Table 14.

Table 14: Identified system limitations that are subject to the RIT-D

System Limitation	Proposed Project Commissioning	Estimated RIT-D Commencement
Augment SMTS-BVE-KMS 66kV Line	2028	Jan 2026
Wollert Zone Substation Development Project (Including 3 feeders - WLT12, WLT13 & WLT14)	2028	Jan 2026

Beveridge ZSS 22kV Feeder Augmentation (Including 3 Feeders - BVE13, BVE14 & BVE21)	2030	June 2026
Pakenham South Zone Substation Development (Including 3 feeders – PHS11, PHS12 & PHS13)	2029	Jan 2026
Supply security of Wonthaggi	2031	Jan 2028
REFCL Driven Augmentation	2026-2031	2026
System security - Implement UFLS	2028-2031	June 2027
Install a new 22kV distribution feeder (WOTS21)	2031	June 2028
Install a new 22kV distribution feeder (CLN32)	2031	June 2027
Install a new 22kV distribution feeder (CRE34)	2029	June 2026
Newmerella Zone Substation asset condition risk	2028	June 2026
Watsonia Zone Substation asset condition risk	To be determined	To be determined
Mount Hotham underground cable condition risk	December 2022	Completed*
ILJIN Manual Switch Replacement-Stage 2	2025	Q1- 2025

\*Staged project, RIT-D requirement in the next EDPR (27-31) to be assessed

## 9. Completed, Committed and Planned Zone Substation and Feeder Developments

This section provides details required by schedule 5.8 (b1), for individual assets planned to be retired, and for schedule 5.8 (g), being for projects within the forward planning period where investments of over \$2 million in value are being implemented to address a refurbishment need, replacement need, or an urgent or unforeseen investment.

### 9.1. Bayswater Zone Substation rebuild

This project is currently in delivery stage to selectively retire and replace 22kV Bus 1 & 2 assets at the Bayswater Zone Substation (BWR). BWR was established in 1968 and contains outdoor bulk oil 22 kV circuit breakers and instrument transformers that were installed when the station was originally built. Secondary equipment panels have asbestos containing materials and live exposed wires at the rear of the secondary panels.

The condition of these assets have deteriorated considerably and they now have an elevated risk of failure. These assets pose unacceptable safety, network security, environmental, and plant damage risks from possible destructive failure.

A project to address these issues, including the following key scope items, is expected to be completed by Dec 2028.

- Replace 22 kV outdoor Bus 1 and 2 switchgears with two new 22 kV indoor switchboards.
- Replace two station services transformers with kiosk modular units
- Replace bushings for existing No3 Transformer 22kV Circuit Breaker
- Replace 22 kV and 66 kV instrument transformers
- Installation of T1 & T2, 22kV Surge Arresters & No3 Trans 66kV SA

Establish new control room and interface Bus 3 retained equipment into replaced Gateway/SCIMS

This project will address asset failure risks due to deteriorated electrical equipment. The total project cost is approximately \$29.1million.

Alternative options considered include:

- Replacing the 22 kV equipment along with the No.2 66/22 kV transformer.
- Replacing the 22 kV equipment along with both the No.1 and No.2 66/22 kV transformers.

While these alternatives deliver greater benefits, the additional advantages are currently insufficient to economically justify the extra cost..

### 9.2. Benalla Zone Substation rebuild and REFCL installation

In September 2023, AusNet completed the 22 kV outdoor switchgear and 66 kV bulk oil circuit breakers at Benalla Zone Substation (BN), including REFCL installation. The condition of these assets deteriorated considerably, and they had an elevated risk of failure. These assets posed unacceptable safety, network security, environmental, and plant damage risks from possible destructive failure and subsequent oil fires. There was also concern that the 22 kV switchgear was not capable to the higher REFCL voltages.

A project to address these issues, including the following key scope items have been recently completed:

- Replace outdoor bulk oil 66 kV circuit breakers with new outdoor 66 kV circuit breakers with estimated total cost of \$10.7M and is expected to be implemented by June 2026

- Replace 22 kV outdoor switchgear with a new 22 kV indoor switchboard under REFCL program A remote REFCL at Violet Town was also required (this scope was delivered under a separate project).

This project addressed asset failure risks due to deteriorated electrical equipment, whilst ensuring integration with the implementation of REFCL technology (see section 13.5.3). The estimated total project cost was approximately \$16.7 million.

### 9.3. Clyde North Zone Substation Capacity Augmentation

AusNet is planning to augment the supply capacity at Clyde North Zone Substation (CLN) to avoid overload of the existing two 66/22 kV 20/33 MVA transformers

A project to address the demand growth driven service level risk, including the following key scope items, is planned to be implemented by 2026:

- Install an additional (third) 66/22kV 20/33 MVA transformer.
- Install an additional (third) 22 kV indoor switchboard.
- Install associated protection and control works.

The design and procurement phase of this project has been completed. Anticipated service date of ZSS works is April 2026.

Separate 22kV feeder projects are proposed to be connected to the new switch room, this shall include three feeders (including one customer feeder). These feeders will provide additional capacity and operational flexibility, enabling off-loading of existing feeders such as CLN11, CLN13, and CRE33.

The works include creating new ties between feeders, rearranging existing feeders, and upgrading overhead and underground infrastructure to improve network reliability and meet future demand.

### 9.4. Kilmore South Zone Substation rebuild

The 22kV indoor switchgear at Kilmore South Zone Substation (ZSS) has degraded to a point where it poses unacceptable safety, network security, environmental and plant damage risks from possible destructive failure and loss of supply. Currently the in-service gear at KMS comprises of an indoor switch board and eight circuit breakers. Because of the condition of the indoor switchboard, this project proposes the removal of all the exiting switchgear and installation of one standard modular indoor switchboard.

The remaining assets at the station have been evaluated and do not pose a worthy risk to warrant replacement in the Kilmore South Zone Substation rebuild project.

The total capital cost of the project is estimated to be approximately \$7 million and has a target completion date of July 2027.

### 9.5. Maffra Zone Substation rebuild

This project is currently in delivery stage to selectively retire and replace assets at the Maffra Zone Substation (MFA). MFA was established with two 10 MVA 66/22 kV transformers in 1960 and contains 66 kV minimum oil circuit breakers and oil filled current transformers that were installed when the station was built. A third transformer was installed in 1998. The condition of the circuit breakers and current transformers has deteriorated considerably, and they now have an elevated risk of failure. These assets pose unacceptable safety, network security, environmental and plant damage risks from possible destructive failure and subsequent oil fires. The condition of the transformers is also deteriorating; however, the replacement of these assets has been deferred to beyond 2026.

A project to address the switchgear condition is expected to be implemented by December 2025, and includes the following key scope items:

- Due to space constraints building new 66kV switchyard for construction of new 66kV ring bus on adjoining land and construction of new control building
- Replace outdoor minimum oil 66 kV circuit breakers with new outdoor 66 kV circuit breakers and adding one tie breaker between Transformer 2 and 3
- Replace outdoor 66 kV current transformers, 66kV voltage transformers, Two NCT's and 22kV capacitor bank.

This project will address asset failure risks due to deteriorated electrical equipment. The total project is approximately \$35.1 million.

Alternative options considered include:

- Replace the two 10 MVA 66/22 kV transformers as well as the 66 kV equipment. This is much higher cost option and replacement of the existing C4 condition transformers is not currently economically justified.
- Replace the 66 kV outdoor switchgear with gas insulated switchgear, while maintaining the original 66/22 kV transformers. This is a high-cost option, due to the increased costs associated gas insulated switchgear, that would deliver less benefits than the proposed preferred option due to the remaining elevated failure risk associated with the two original transformers.
- Replace the 66 kV outdoor switchgear with new outdoor 66 kV switchgear and replace one of the two original 66/22 kV transformers. This is a lower cost option than the proposed preferred solution, but also has lower benefits due to the remaining elevated failure risk associated with the one original transformer that would not be replaced.

## 9.6. Newmerella Zone Substation rebuild

AusNet is planning to retire and replace assets at the Newmerella Zone Substation (NLA). NLA is a small remote zone substation containing two 5 MVA 66/22 kV transformers and a single outdoor 22 kV bus with outdoor 22 kV automatic circuit recloser (ACR) switches in place of traditional 22 kV circuit breaker switchgear. The condition of the two transformers and the 22 kV switchgear has deteriorated and they now have an elevated risk of failure. The assets pose unacceptable safety, network security, environmental and plant damage risks from possible destructive failure and subsequent oil fires and loss of supply.

A project to address these issues was planned for 2024 but has now been delayed to 2027 following more detailed assessment of the service level risk. Key scope items include:

- Replace the two 66/22 kV transformers
- Replace outdoor 22 kV circuit breakers with a new indoor 22 kV switchboard.
- Replace the six 66kV voltage transformers

This project will address the service level risk associated with the 66/22 kV transformers and 22 kV assets. The total project cost in 2024 real dollars is approximately \$19.64 million  $\pm$ 30%.

Alternative options considered include:

- Replace only the existing outdoor 22 kV switchgear with a new indoor 22 kV switchboard. This is lower cost option but does not address the service level risk associated with the poor transfer condition.
- Replace the 66/22 transformers, while maintaining the existing outdoor 22 kV switchgear. This is medium cost option, due to the transformer replacements, however the benefits are limited due to the remaining elevated failure risk associated with the existing outdoor 22 kV switchgear.

## 9.7. Thomastown Zone Substation rebuild

This project is currently in delivery stage to selectively retire and replace assets at the Thomastown Zone Substation (TT). TT was established in the early 1950s and contains 66 kV and 22 kV bulk oil circuit breakers that were installed when the station was built. The condition of these circuit breakers has deteriorated considerably, and they now have an elevated risk of failure. These assets pose unacceptable safety, network security, environmental and plant damage risks from possible destructive failure.

A project to address these issues, includes the following key scope items, with scope being delivered partial deferment

- Replace outdoor bulk oil 22 kV circuit breakers with three new indoor 22 kV switchboards.
- Replace outdoor bulk oil 66 kV circuit breakers with new outdoor 66 kV circuit breakers.
- Replace the three 66kV/22kV transformers
- Associated protection and secondary system upgrades.

The preferred option is to complete this work in two stages. The scope of Stage 1 will replace two existing 66kV circuit breakers with associated works by March 2026 and Stage 2 will comprise the remaining scope of work. Stage 2 will be completed 5-10 years after Stage 1, with the works currently planned for completion in 2030.

The total capital cost of stage 1 is this option is \$8.5 million (real \$2022). With stage 2 costing 27.39 million (real \$2024).

## 9.8. Traralgon Zone Substation rebuild

AusNet is currently in the design and procurement stages of a project to selectively retire and replace assets at the Traralgon Zone Substation (TGN). Construction is planned to commence mid-2024. The project is expected to be completed by March 2026.

TGN was established with two 10/13.5 MVA 66/22 kV transformers and contains outdoor 66 kV and 22 kV oil filled switchgear that was installed when the station was built. A 20/33 MVA transformer, in addition to the two original 10/13.5 MVA transformers, was installed in 2013. The condition of the two original transformers and the 66 kV and 22 kV assets has deteriorated considerably, and they now have an elevated risk of failure. These assets pose unacceptable safety, network security, environmental and plant damage risks from possible destructive failure.

A project to address these issues, includes the following key scope with scope being investigated for partial deferment. The scope of items are:

- Replace the two 10/13.5 MVA 66/22 kV transformers with a single 20/33 MVA 66/22 kV transformer.
- Replace two 66 kV minimum oil circuit breakers.
- Replace outdoor 22 kV switchgear with a new indoor 22 kV switchboard.
- Replace the high voltage 66 kV transformer bushings.

The preferred option is to complete this work in two stages. Stage 1 will replace two existing 66kV circuit breakers and two 10/13.5 MVA 66/22 kV transformers with associated works by May 2027 and Stage 2 will comprise the remaining scope of work. Stage 2 will be completed 5-10 years after Stage 1, with the works currently planned for completion in 2030.

The total capital cost of this option is \$18.86 million (real \$2024) for stage 1 and \$11.74 million for stage 2 .

Alternative options considered include:

- Replace the 66 kV and 22 kV assets, while maintaining the existing transformers. This is a lower cost option than the proposed preferred solution but results in lower net economic benefits due to the remaining elevated failure risk associated with the two 66/22 kV transformers.
- Replace only the 22 kV assets, while maintaining the existing 66 kV assets and transformers. This is a much lower cost option than the proposed preferred solution but results in lower net economic benefits due to the remaining elevated failure risk associated with the 66 kV assets and the two 66/22 kV transformers.

## 9.9. Warragul Zone Substation rebuild

This project is currently in delivery stage to selectively retire and replace assets at the Warragul Zone Substation (WGL). The condition of the original transformers and the 66 kV and 22 kV assets has deteriorated considerably, and they now have an elevated risk of failure. These assets pose unacceptable safety, network security, environmental and plant damage risks from possible destructive failure.

A project to address these issues is expected to be implemented by October 2026, and includes the following key scope items:

- Replace the four 10 MVA 66/22 kV transformers with two 20/33 MVA 66/22 kV transformers.
- Replace the No.2 capacitor bank with a new 12MVA unit.
- Install four new 66 kV circuit breakers to complete a fully switched ring bus.

- Replace the Neutral Earthing Resistor.
- Install a new modular control building
- Replace existing station DC supplies

This project will address the asset failure risks due to deteriorated electrical equipment and provide some additional capacity to supply the station load. The total project cost is approximately \$31 million. In addition to this project, a new feeder and associated switchboard is required to be installed at WGL before 2031 due to high demand growth seen in this area.

## 9.10. Watsonia Zone Substation rebuild

AusNet planned to selectively retire and replace assets at the Watsonia Zone Substation (WT). WT was established with two 66/22 kV transformers in the late 1950s, with a third transformer installed in 2010, and contains 22 kV bulk oil circuit breakers that were installed when the station was built.

The project had the following key scope items:

- Replace outdoor bulk oil 22 kV circuit breakers with new indoor 22 kV switchgear.
- Replace the two poor condition 66/22kV transformers
- Associated protection and secondary system upgrades.

Alternative options considered include:

- different stagings of the project
- Retiring One transformer
- defer retirement and replacement

This project was to address 22kV switchgear and the 66/22 kV transformer failure risk. The total project cost was approximately \$48.95 million  $\pm$ 30%. However, when preparing the RIT-D Draft Project Assessment Report (DPR), the condition of the assets at Watsonia Zone Substation was reviewed using a new asset modelling tool. The conclusion of this review is that the condition of the assets does not warrant remedial action during the current planning period. Accordingly, AusNet didn't proceed with the remainder of the RIT-D process in relation to Watsonia Zone Substation. AusNet will recommence the RIT-D process when the asset condition at Watsonia Zone Substation warrants remedial action possibly in the next EDPR (2027-31).

## 9.11. Wollert New Zone Substation

The Northern Growth Corridor, is a high growth area, and Ausnet has experienced significant growth over the past few years, particularly over the recent 2024/25 summer. The City of Whittlesea (which Wollert is a part of) is expected to grow annually at an average of 2.5% between 2021 and 2036 – and is among the higher growth areas across the Victorian local government areas (LGA). The demand forecasts are expected to exceed the ratings of several 22kV distribution feeders and the KLO Zone Substation by the end of the next regulatory period.

Projects to address the demand growth driven service level risk, including the following key scope items, is planned to be implemented after 2026:

- **Build a new Zone Substation at Wollert (WLT):** This involves augmenting the network by installing a new 2x33MVA 66/22kV zone substation located close to the existing dual circuit 66 kV lines on the eastern edge of the Wollert precinct. This option relieves the loading at surrounding zone substations to reduce expected unserved energy and ensures there is sufficient capacity in Wollert to address the forecasted demand.
- **Wollert ZSS 22kV Feeder Augmentation (3 Feeders):** 3 feeders – WLT12, WLT13 & WLT14 are planned to be commissioned in FY2028 to supply the required load growth in the Wollert area.
- **Wollert ZSS 22kV Feeder Augmentation (1 Feeder):** 1 feeder – WLT21 will be established. To supply the required load growth in the Wollert area and is planned to be commissioned in FY2029.

## 9.12. Wonthaggi Zone Substation Upgrade

The town of Wonthaggi and surrounding areas including Inverloch and San Remo are predominately serviced by 66/22kV Wonthaggi (WGI) zone substation (ZS) established in the mid-1960s. Currently it has three, aged 10/13.5 MVA transformers in deteriorating conditions and seven 22kV feeders with outdoor 66kV and 22kV switchgear in an un-switched configuration.

By 2053, the population growth in Wonthaggi and surrounding areas including Inverloch and San Remo will ultimately result in approximately 4,500<sup>16</sup> new residential dwellings and 70 hectares of employment land comprise industrial and commercial developments - town centres, schools, community facilities, and future commercial spaces. When fully developed beyond 2053, it is expected that the development areas in Wonthaggi and surrounding areas, including Inverloch and San Remo, will result in a new load in the order of 44 MVA being added to AusNet Services' electricity network in South Gippsland.

To address this need, the option to replace 1 x 10/13.5 MVA Tx with 1 x 20/33 MVA Tx is currently being considered. The Wonthaggi (WGI) zone substation has enough room to ultimately be developed to have three 20/33 MVA transformers (replacing the current transformers) and indoor 22 kV switchgear arranged in three buses with twelve 22kV feeders.

## 9.13. Pakenham South New Zone Substation

The Victorian Planning Authority (VPA) has outlined a long-term vision for Melbourne's South-Eastern Growth Corridor within the growth area municipalities of Cardinia and Cardinia, focusing on coordinated development across rapidly expanding suburbs which includes Pakenham, Officer and Clyde areas, significant growth is expected in next 5 years, driven by Precinct Structure Plans (PSPs) and Infrastructure Development Sequencing Plans (IDSPs).

The forecasted demand growth and limitations of existing infrastructure necessitate the establishment of a new zone substation at Pakenham South to ensure supply security for the corridor. The proposed site, near the CLN-PHM-LLG 66 kV sub-transmission line tee joint, is strategically located for optimal network integration.

The proposed new zone substation scope will include Installation two (2) 20/33 MVA, 66/22 kV power transformers two (2) 22 kV urban switchboards with construction of three (3) new 22 kV feeders to be delivered by FY2028. An additional feeder will be delivered by FY2030.

## 9.14. Further REFCL installation and geographic footprint

The installation and application of REFCL technology at twenty-two of AusNet zone substations was enacted on 1 May 2016 in the Electricity Safety (Bushfire Mitigation) Amendment Regulations 2016 by the Victorian Government. The Regulations are highly prescriptive and ambitious, detailing a seven-year implementation timeframe and performance standards that will be administered by Energy Safe Victoria.

The Bushfire Mitigation Regulations stipulate three tranches, with delivery due by May 2019, 2021 and 2023-

The twenty-two (22) REFCL zone substations are Kinglake (KLK), Woori Yallock (WYK), Kilmore South (KMS),

Wangaratta (WN), Rubicon A (RUBA), Barnawartha (BWA), Seymour (SMR), Myrtleford (MYT), Wonthaggi (WGI),

Benalla (BN), Ringwood North (RWN), Eltham (ELM), Ferntree Gully (FGY), Belgrave (BGE), Lilydale (LDL), Bairnsdale (BDL), Moe (MOE), Sale (SLE), Mansfield (MSD), Wodonga Terminal Station 22 kV switchyard (WOTS), Lang Lang (LLG), and Kalkallo (KLO).

Of the twenty-two (22) REFCL zone substation sites, all have achieved compliance. Due to reaching capacity and in order to maintain compliance at two sites, Bairnsdale (BDL) and Lilydale (LDL) will require further augmentation next year. Remote REFCLs and third GFN solutions have been evaluated. To, to ensure compliance in the upcoming regulatory period, additional augmentation will be required at Zone Substations SMR, WOTS, WYK, and KLK. Beyond

<sup>16</sup> Source: [2019-04-18-Wonthaggi-Structure-Plan-and-Discussion-Paper-FINAL.PDF \(basscoast.vic.gov.au\)](#)

the capacitance limits at the zone substation buses, some individual 22kV feeders also have a sub-limit of 80A. Therefore, the configuration of each ZSS— along with load forecasts and downstream network topology— will determine the appropriate set of solutions for these sites. The Electricity Distribution Code (Version 9A), amended in August 2018, requires AusNet to identify all areas affected under a 'REFCL condition' in its DAPR. Figure 13 and Figure 14 below identify the geographic locations where a REFCL condition may be experienced.

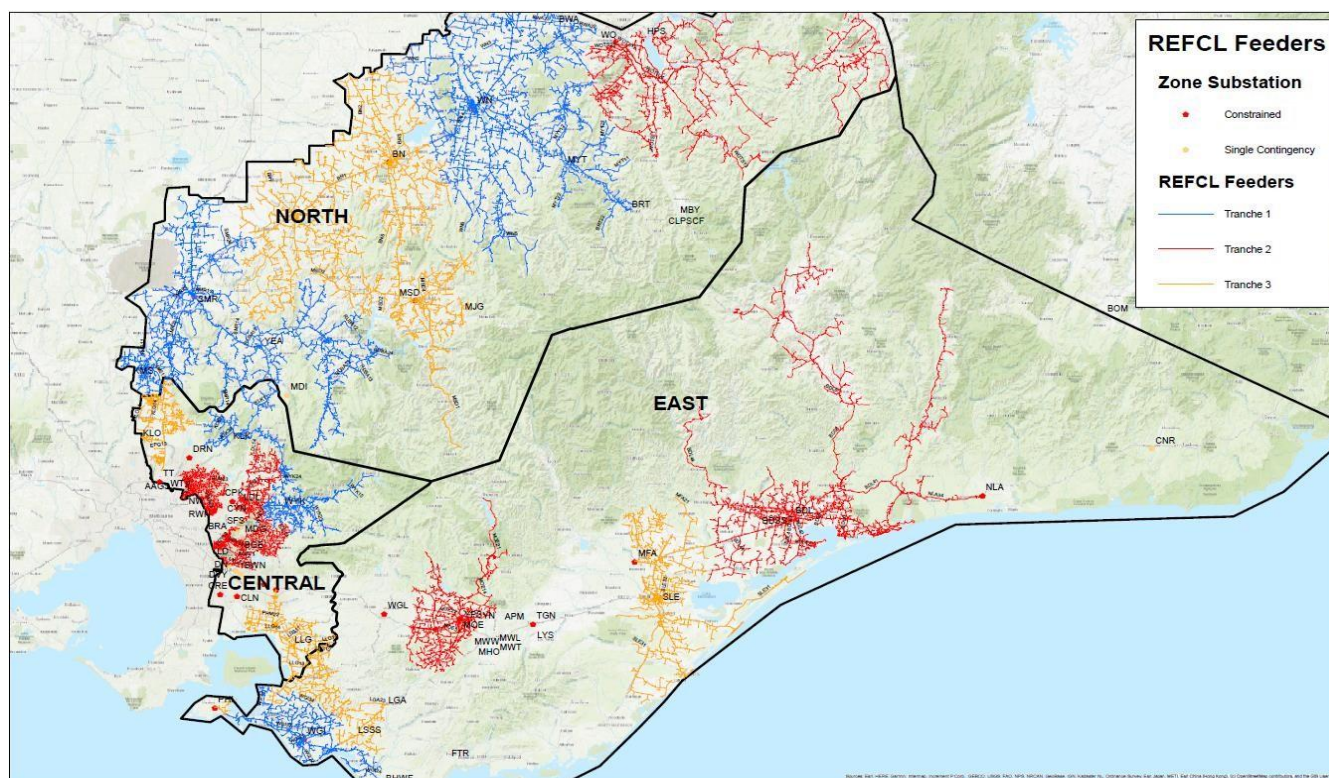

Figure 13: Feeders subject to a REFCL condition, by original tranche

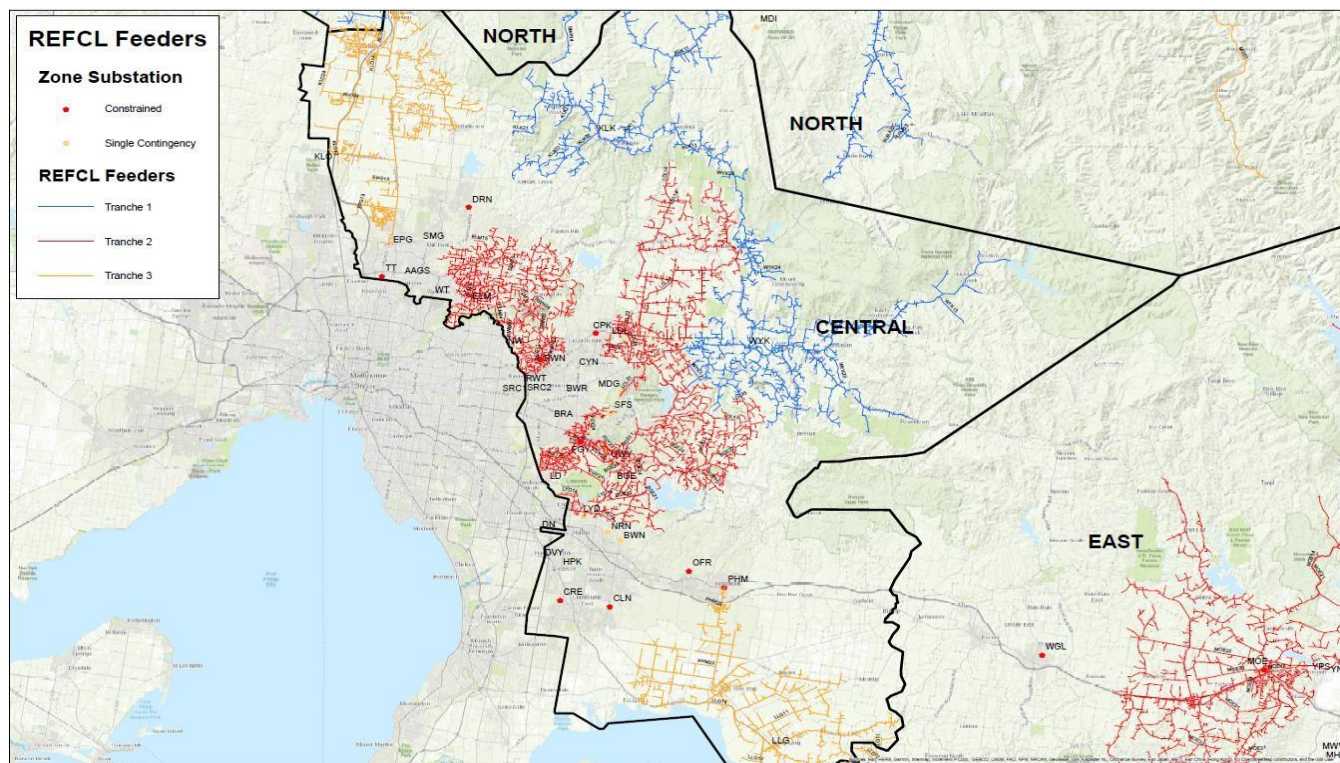

Figure 14: Feeders subject to a REFCL condition, by original tranche – Central region focus

## 9.15. Beveridge Zone Substation Development Project

The Northern Growth Corridor<sup>1</sup> on the urban fringes of Melbourne’s northern suburbs is a vast greenfield development area accommodating much of Melbourne’s population and economic growth. There has been a significant increase in population in the Beveridge area. According to the 2016 census<sup>2</sup>, there were 1,874 people living in Beveridge and by 2021<sup>3</sup>, the corresponding figure was 4,642. This represents an average annual growth rate of approximately 30%. It is expected that growth is likely to continue with the most recent forecast produced by Victoria’s Department of Transport and Planning (VIF2023)<sup>4</sup> forecasting the population of the Mitchell local government area (LGA), which contains Beveridge, to grow from 49,460 to 69,600 from 2021 to 2026. This represents an overall annual growth rate for the whole LGA of 8.1% per annum.

The Beveridge area is currently supplied in part by AusNet’s existing Kalkallo zone substation (KLO) through a rural network of 22 kV distribution feeders. Kalkallo zone substation (KLO) supplies over 17,439 AusNet customers (via five 22 kV distribution feeders), and over 13,448 Jemena Electricity Network (JEN) customers (via four 22 kV distribution feeders). AusNet has identified increasing energy at risk in parts of this network, including the Kalkallo zone substation, due to rapid demand growth in the Northern Growth Corridor. Significant load growth has been observed on the two AusNet 22 kV distribution feeders - KLO14 and KLO24 - supplying the satellite suburbs of Beveridge, Wallan, parts of Wandong and Whittlesea, and their surrounds. Bushfire mitigation technology, specifically Remote REFCLs, has been deployed on both feeders.

To cater for this growth, AusNet is developing a project to establish a new 66/22 kV zone substation with 2 x 33 MVA transformers and two 22 kV busbar and new 22 kV feeder exits connected into the existing 22 kV distribution network, at a site located close to an existing 66 kV sub-transmission line on the western side of Beveridge.

The project addresses the identified need by removing the existing overload on KLO14 and KLO24 and adding the forecast demand growth onto the new feeders at the Beveridge zone substation.

## 9.16. Construct a new 22kV distribution feeder at Cranbourne Zone Substation

To address forecasted demand growth in the Cranbourne area and maintain network reliability, this project involves establishing a new feeder, CRE34, from the existing switch room at Cranbourne Zone Substation.

The new feeder will help offload the heavily loaded CRE21 feeder, reducing the risk of supply disruptions and supporting ongoing development. Works include routing the feeder west from the zone substation along Evans Road and Thompsons Road and connecting new kiosks to the existing network to enhance capacity and flexibility.

# 10. Joint planning with the Transmission Network Service Provider

In accordance with clause 5.14 of the NER, AEMO and the Victorian DNSPs undertake joint planning to ensure the efficient development of the shared transmission and distribution networks and the transmission connection facilities. To formalise these arrangements, the parties have agreed a Memorandum of Understanding (MoU).

The MoU sets out a framework for cooperation and liaison between AEMO and the DNSPs regarding the joint planning of the shared network and connection assets in Victoria. The MoU sets out the approach to be applied by AEMO and the DNSPs in the assessment of options to address limitations in a distribution network where one of the options consists of investment in dual function assets or transmission investment, including connection assets and the shared transmission network. Under the MoU, the DNSPs and AEMO have agreed that, subject to the thresholds set out in the Rules, joint planning projects should be assessed by applying the RIT-T. The DNSPs also liaise regularly with AusNet Transmission Group, the majority owner of the Victorian transmission network, to coordinate their transmission connection augmentation plans with AusNet Transmission Group's asset renewal and replacement plans.

Clause 5.13.2(d) of the NER stipulates that a DNSP is not required to include in its DAPR information required in relation to transmission-distribution connection points if it is required to do so under jurisdictional electricity legislation (i.e., the Victorian EDCoP clause 19.3). The information for schedule 5.8 (h) regarding the results of any joint planning undertaken with the Transmission Network Service Provider (TNSP) has been included in the TCPR covering the period 2023-2032<sup>17</sup> and to avoid duplication is generally not repeated in this report. As required under schedule 5.8 (h), the TCPR contains a summary of the process and methodology used, a brief description of investments that have been planned (including the estimated capital costs of the investment and an estimate of the timing), and references to where additional information may be obtained.

Schedule 5.8(o) of the NER requires AusNet to report on analysis of known and potential interactions between control systems including a description of proposed actions to be undertaken to address any adverse interactions, considering the most recent general power system risk review undertaken by AEMO.

In July 2022, AEMO published its final report on the Power System Frequency Risk Review<sup>18</sup> which details the adverse impacts that increasing levels of distributed embedded generation has on the Under Frequency Load Shedding (UFLS) control scheme, causing minimum operational demand to fall below technically acceptable thresholds needed for the effective operation of the control scheme.

Under the NER, AEMO has primary responsibility for system security, however there is a general obligation on NSPs<sup>19</sup> to respond to AEMO's direction by developing and implementing solutions to mitigate grid security risks. In August 2021, AEMO issued a directive to Victorian NSPs to identify and implement measures to restore emergency underfrequency response to as close as possible to the level of 60% of underlying load<sup>20</sup> in all periods. In response, a working group was set up between the Victorian Department of Environment, Land, Water and Planning (DELWP), AEMO and the Victorian NSPs to collaboratively identify solutions to address emerging issues associated with minimum demand and the UFLS scheme in Victoria. This joint planning working group is expected to continue to be an ongoing collaborative exercise well into the next year.

AusNet is currently investigating options to install/enable under-frequency tripping relays with reverse flow blocking capability at 66kV sub-transmission lines within the AusNet distribution network.

<sup>17</sup> A copy of the Transmission Connection Planning Report and Terminal Station Demand Forecasts can be viewed at AusNet website: [AusNet - Rosetta Data Portal \(ausnetservices.com.au\)](https://ausnetservices.com.au).

<sup>18</sup> [Power System Frequency Risk Review](#), AEMO, July 2022.

<sup>19</sup> [Clause 4.3.3](#) of the NER.

<sup>20</sup> [Clause 4.3.1\(k\)](#) of the NER.

# 11. Joint planning with other Distribution Network Service Providers

This section provides details required by Schedule 5.8 (i) covering projects which AusNet is developing under joint distributor arrangements that are expected to commence in the next five-year period from 2023.

## 11.1. Distribution Network Service Providers' Joint Planning Process

AusNet engages with neighbouring DNSPs when required to plan for network upgrades where networks cross the boundaries between a neighbouring DNSP. AusNet has one 66 kV sub-transmission loop that is shared with United Energy and one 66 kV sub-transmission loop that is shared with Jemena. There are also some small sections of 22 kV feeders that provide energy to customers in a neighbouring DNSP and vice versa.

## 11.2. Jointly planned projects

Excluding joint planning of transmission connection assets, which are discussed in the TCPR, AusNet currently has no joint distribution planning project underway.

# 12. Performance of AusNet Network

This section highlights the performance of AusNet Distribution Network required under schedule 5.8 (j).

## 12.1. Reliability measures and standards in applicable regulatory instruments

The Distribution Use of System (DUoS) charges that AusNet levies to electricity retailers and some large customers are adjusted each year in accordance with price controls established by the Australian Energy Regulator (AER).

The Service Target Performance Incentive Scheme (STPIS) provides financial incentives for DNSP to maintain and improve service performance. Performance targets are set based on historical performances of the individual DNSP; thus, providing financial rewards for DNSPs beating their targets and financial penalties for failing to meet targets.

The STPIS applying to AusNet has two components:

- A reliability of supply component (S-Factor) which adjusts the revenue that a DNSP earns depending on reliability of supply.
- A Guaranteed Service Level (GSL) component which sets threshold levels of service for DNSPs to achieve and requires direct payments to customers who experience service worse than the predetermined level.

AusNet is also incentivised to maintain and improve customer service performance through the Customer Service Incentive Scheme (CSIS).

Table 15 shows the targets for the 2021-2026 regulatory control period.

**Table 15: Period 2021-2026 performance targets for USAIDI, USAIFI and MAIFI**

Measure	Feeder Class	2021-2026
Unplanned SAIDI	Urban	87.190
	Rural Short	195.160
	Rural Long	293.692
Unplanned SAIFI	Urban	0.891
	Rural Short	2.007
	Rural Long	2.628
Unplanned MAIFI	Urban	2.817
	Rural Short	5.657
	Rural Long	9.920

Source: FINAL DECISION AusNet Distribution Determination 2021 to 2026 Attachment 10 Service target performance incentive scheme, April 2021, pp10-6.

### Notes:

- USAIDI (Unplanned System Average Interruption Duration Index, or the average minutes a customer is off supply each year resulting from unplanned outages with duration greater than three minutes).

- USAIFI (Unplanned System Average Interruption Frequency Index, or the average number of times a customer is off supply each year resulting from unplanned outages with duration greater than three minutes).
- MAIFI (Momentary Average Interruption Frequency Index or the average number of times a customer is off supply for less than three minutes each year).
- Call centre performance (the percentage of fault calls progressing to an operator that are answered within 30 seconds).
- For the 2021-2026 regulatory control period, AusNet have opted to apply a Customer Service Incentive Scheme (CSIS) rather than the STPIS telephone answering parameter, however it is proposed that AusNet continue to report on the telephone answering parameter for transparency purposes.

Table 16 summarises the supply restoration and low reliability payments schemes applicable in the current (2021 to 2026) EDPR period.

**Table 16: GSL Supply Restoration and Low Reliability Payments – 2021 to 2026**

Measure	Condition	Amount
Duration	Where the customer experiences more than 18 hours of unplanned sustained interruptions per year; or	\$ 130
	Where the customer experiences more than 30 hours of unplanned sustained interruptions per year; or	\$ 190
	Where the customer experiences more than 60 hours of unplanned sustained interruptions per year;	\$ 380
Number of Sustained Outages	Where the customer experiences more than 8 unplanned sustained interruptions per year; or	\$ 130
	Where the customer experiences more than 12 unplanned sustained interruptions per year; or	\$ 190
	Where the customer experiences more than 20 unplanned sustained interruptions per year	\$ 380
Number of Momentary Outages	Where the customer experiences more than 24 momentary interruptions per year; or	\$ 40
	Where the customer experiences more than 36 momentary interruptions per year.	\$ 50
Major Event Day	Where the customer experiences an unplanned sustained interruption of more than 12 hours on a major event day.	\$ 90

Source: Electricity Distribution Code review – customer service standards, Final decision, 16 November 2020, pp. 45-46

### 12.1.1. Exclusion Criteria

Section 3.3 of the revised Electricity Distribution Network Service Providers – STPIS Nov 2018 outlines the exemption criteria applicable in the EDPR period 2016-2020. The same set of criteria is applicable to the EDPR period 2021-2026. Events that fall in any of the following conditions may be excluded in calculating the revenue increment or decrement as well as annual performance under the STPIS scheme.

Exclusions include:

- (a) The following events may be excluded when calculating the revenue increment or decrement under the scheme when an interruption on the DNPS's distribution network has not already occurred or is concurrently occurring at the same time:
  - Load shedding due to a generation shortfall.
  - Automatic load shedding due to the operation of under frequency relays following the occurrence of a power system under-frequency condition.
  - Load shedding at the direction of AEMO or a system operator.
  - Load interruptions caused by a failure of the shared transmission network.
  - Load interruptions caused by a failure of transmission connection assets except where the interruptions were due to:
    - (a) actions, or inactions, of the DNSP that are inconsistent with good industry practice; or
    - (b) inadequate planning of transmission connections and the DNSP is responsible for transmission connection planning.

Example: a DNSP omits to suppress back-up earth fault (BUEF) protection when undertaking network switching operation that results in momentary paralleling of supplies from two different terminal stations, where this is inconsistent with the standard practice.
  - Load interruptions caused by the exercise of any obligation, right or discretion imposed upon or provided for under jurisdictional electricity legislation or national electricity legislation applying to a DNSP.
  - Load interruptions caused or extended by a direction from state or federal emergency services, provided that a fault in, or the operation of, the network did not cause, in whole or part, the event giving rise to the direction.
- (b) An event may also be excluded where daily unplanned SAIDI for the DNSP's distribution network exceeds the major event day (MED) boundary.

In addition to the above set of criteria, the AER considers that avoidable supply interruptions due to the suppression of the auto-recloser system under an approved Electricity Safety Management Scheme would meet the exclusion criteria under clause 3.3(a)(7) of the STPIS.

## 12.2. Performance against reliability measures and standards

Table 17 summarises the reliability performance of the electricity distribution network for the EDPR FY22-FY26 to date. Total performances with and without exemptions are shown in Table 17 along with individual targets, which include exemptions, for each feeder category.

**Table 17: Network Performance Summary**

Measure	Feeder Class	5yr Target	RY22 Actual	RY23 Actual	RY24 Actual	RY25 Actual	RY26 F'cast
---------	--------------	------------	-------------	-------------	-------------	-------------	-------------

Unplanned SAIDI	Urban	87.190	72.182	75.525	110.388	83.108	76.615
	Rural Short	195.160	192.617	195.819	169.571	271.438	177.989
	Rural Long	293.692	285.002	351.194	281.800	462.673	307.064
Unplanned SAIFI	Urban	0.891	0.682	0.621	0.984	0.708	0.809
	Rural Short	2.007	1.362	1.380	1.245	1.869	1.844
	Rural Long	2.628	1.832	2.307	2.020	2.536	2.697
Unplanned MAIFI	Urban	2.817	3.244	3.060	2.949	2.578	2.658
	Rural Short	5.657	5.317	4.833	4.220	4.675	5.033
	Rural Long	9.920	10.460	9.581	6.534	7.714	9.026

RY25 is the fourth regulatory year of the current price reset period in financial (July-June) cycle. After removing exclusions, performances for SAIFI and MAIFI were all favourable against targets across all feeder categories. Urban feeder USAIDI performance was favourable overall compared to rural feeders that were heavily impacted by moderate storm events in January and February 2025.

During the year, three major event days (MED) were recorded with a combined impact of ~244 USAIDI minutes. There was no transmission network event recorded in RY25 that resulted to customer interruptions in the distribution network. However, eight inter-DB faults that originated from other distribution network service providers (DNSP) impacted AusNet customers with a combined USAIDI of 0.26 minutes. There were five unplanned incidents associated with asset failures caused by REFCL pre-conditioning or compliance tests resulted to 1.14 USAIDI minutes lost. Another 107 unplanned incidents accumulated 24.98 USAIDI minutes because of the mandatory operation or REFCLs at increased sensitivity. Seven unplanned incidents during total fire ban (TFB) days in which causes were not found accumulated 6.4 minutes. These STPIS exclusions are summarised in Table 18.

**Table 18: Summary of Exclusions**

Event Description	Exclusion Criteria	USAIDI, Minutes					
		CY20	HY1-2021	FY22	FY23	FY24	FY25
Load shedding - generation shortfall	3.3(a)(2)	-	-	-	-	-	-
Load shedding - under frequency	3.3(a)(3)	-	-	-	-	-	-
Load shedding - AEMO	3.3(a)(4)	-	0.02	-	-	-	-

Transmission - shared network	3.3(a)(5)	0.26	-	-	-	-	-
Transmission - asset failure	3.3(a)(6)	6.62	1.55	0.37	-	1.10	0.26
Imposed obligation by legislation	3.3(a)(7)	8.03	5.46	0.65	7.21	24.80	32.53
Imposed restrictions by authorities	3.3(a)(8)	-	-	-	-	-	-
Major Event Days	3.3(b)	196.84	794.49	392.27	26.75	672.56	243.68

Table 19 summarises the supply restoration and low reliability GSL performance for FY24-25.

**Table 19: Summary of Reliability of Supply GSL**

AusNet Measure	Supply Interruption Condition	Payment	Number of eligible customers	Amount
Duration of Interruption	>18 hrs.	\$130	25,515	\$3,316,950
	>30 hrs.	\$190	7,920	\$1,504,800
	>60 hrs.	\$380	1,543	\$586,340
Number of Sustained Outages	> 8 interruptions	\$130	8,147	\$1,059,110
	> 12 interruptions	\$190	1,034	\$196,460
	> 20 interruptions	\$380	0	0
Number of Momentary Outages	> 24 interruptions	\$40	6982	\$279,280
	> 36 interruptions	\$50	583	\$29,150
Interruption	Major Event Day	\$90	95,222	\$8,569,980
<b>TOTAL</b>			146,946	\$15,542,070

### 12.2.1. Inadequately Served Customers

On 5 September 2014, the Australian Energy Market Commission (AEMC) released the final report on the **Review of Distribution Reliability Measures**. A chapter was dedicated discussing the factors “the AER should have regard to when developing a method for assessing the trade-offs between reliability and cost in those areas that experience lower levels of reliability of electricity supply”. This report recognises that reliability experienced by some customers in a distribution network can be materially lower than that experienced by many (i.e. average) of the other customers in that network.

On 14 November 2018, the Australian Energy Regulator (AER) released a report on **Distribution Reliability Measures Guideline**. Prior to this release, the AER and state regulators define how reliability should be measured making it hard to compare performances across Australia. The AEMC implemented a rule change that required the development of common definitions and measurements for distribution reliability in the National Electricity Market (NEM).

In the AERs new guideline, the **Inadequate level of service customer** was defined as customer experiencing greater than 4 times the Network average for unplanned SAIDI on a three-year rolling average basis compared with a

network average customer. Consequently, the AER now requires DNSPs to report **Inadequately Served Customers** in the annual RIN submissions.

**Table 20: RY25 Inadequately served customer statistics**

INADEQUATELY SERVED CUSTOMERS		
		Number
<b>A - SAIDI VALUES</b>		
Threshold SAIDI value for inadequately served customers	SAIDI	2,080
Average unplanned SAIDI of inadequately served customers	SAIDI	3,055
Highest unplanned SAIDI of inadequately served customers	SAIDI	4,723
<b>B - SAIFI VALUES</b>		
Average unplanned SAIFI of inadequately served customers	SAIFI	4.01
Highest unplanned SAIFI of inadequately served customers	SAIFI	7.04
<b>C - TOP 5 FEEDERS WITH MOST INADEQUATELY SERVED CUSTOMERS</b>		
<b>SAIDI VALUE</b>		
BGE22		4,723
FTR12		3,572
LGA11		3,495
BGE13		2,989
LGA13		2,968
<b>SAIFI VALUE</b>		
BGE22		7.04
FTR12		3.95
LGA11		3.11
BGE13		5.50
LGA13		2.19
<b>NUMBER OF INADQUATELY SERVED CUSTOMERS</b>		
BGE22		3,367
FTR12		1,647
LGA11		1,729

BGE13		1,626
LGA13		915

## 12.3. Corrective Actions – Reliability

The following subsections detail corrective actions that have been taken in relation to reliability and quality of supply.

### 12.3.1. Corrective Action – Reliability

AusNet is focusing on improving the distribution network's reliability performance by systematically reviewing poorly performing segments and investing in technology that automatically reconfigures the affected network to minimise the number of customers affected by outages.

AusNet will continue to monitor the reliability performance and take appropriate actions to outperform the targets. These include installing additional switches, fuses, auto circuit reclosers, sectionalisers, vegetation management, animal proofing and protection coordination improvements.

### 12.3.2. Performance Evaluation Method

When evaluating reliability performance, it is important to use a methodology that employs statistical analysis of long run trends rather than a year-to-year or year-to-target comparison. This avoids implementing an investment strategy that reacts to recent events, rather than a predictive strategy focussed on closing the gap between current performance and future targets. Accordingly, AusNet:

- Normalises the impact of external factors, such as weather, on annual performance.
- Uses weighted five-year performance to identify underperforming circuits.
- Employs statistical mean and standard deviation to analyse the significance of variations in performance indicators.
- Internally reports daily reliability performance against targets, for both unplanned and planned outages.
- Conducts regular meeting between the reliability improvement team, to discuss improvement measures for current reliability issues.
- Closely monitors low reliability feeders.
- Participates in benchmarking study to identify the strengths and the weaknesses of regional areas when compared to best practice.
- Assesses in detail how the network performed during storm events to maintain trending data and determine opportunities future asset programs.
- Monitors repetitive faults in the network monthly to establish emerging problems.
- Monitors performance of distribution feeders for which new initiatives have been implemented to identify their effectiveness and if opportunities exist to extend these programs.
- Undertakes analysis of any event that contributed 0.3 USAIFI or more and any large event that contributed 2.0 USAIDI minutes or more, to determine improvement opportunities in terms of AusNet response to the outage events from both an operational and strategic perspective.

## 12.4. Quality of supply standards

The quality of supply standards that apply to Victorian DNSPs are stipulated in the EDCoP published by the Essential Services Commission (ESC), Victoria. The Electricity Distribution License issued by the ESC to AusNet Electricity Services Pty Ltd requires compliance with the EDCoP. The EDCoP provides standards and guidelines in relation to following quality of supply parameters.

AusNet is committed to maintaining power supply quality within the limits specified in the above code and relevant standards. The following power quality parameters are discussed in this section:

- Voltage standards
- Power factor
- Harmonics
- Inductive interference
- Load balancing (Negative sequence voltage)
- Flicker

### 12.4.1. Voltage Standards

The EDCoP specifies the voltage levels that must be maintained at the meter or point of supply to the customer's electrical installation. These levels are:

- 230 V (meter)
- 400 V (meter)
- 460 V (meter)
- 6.6 kV (point of supply)
- 11 kV (point of supply)
- 22 kV (point of supply)
- 66 kV (point of supply).

The EDCoP clause 20.4 specifies the Standard Voltage Variations limits at each voltage level. These levels are specified in Table 21 below.

**Table 21: Standard Nominal Voltage Variations**

	Voltage Level in kV	Standard Nominal Voltage Variations			Impulse Voltage
		Steady State	Less than 1 minute	Less than 10 seconds	
1	< 1		AS 61000.3 .100*		6 kV peak
2		+13 % -10 %	+13 % -10 %	Phase to Earth +50%-100% Phase to Phase +20%-100%	
3	1-6.6	± 6 % (± 10 % Rural Areas)	± 10 %	Phase to Earth +80%-100% Phase to Phase +20%-100%	60 kV peak
4	11				95 kV peak
5	22				150 kV peak
	Voltage Level in kV	Standard Nominal Voltage Variations			Impulse Voltage
		Steady State	Less than 1 minute	Less than 10 seconds	
6	66	± 10%	± 15%	Phase to Earth +50%-100% Phase to Phase +20%-100%	325 kV peak

Notes:

\* When examining network-wide compliance, functional compliance is met if the limits in Table 2 of AS 61000.3.100 (up to 1% of measurements below 216 V and up to 1% of measurements above 253 V) are maintained across at least 95% of a distributor's customers.

\*\* Row 2 values (steady state, less than 1 minute, and less than 10 seconds) define the circumstances in which a distributor must compensate a person whose property is damaged due to voltage variations according to clause 20.4.8. Schedule 3 of the EDCoP illustrates this further.

The Phase to Earth voltage variations in Table 21 above does not apply during the period in which a REFCL condition is experienced on the distribution system (including when a REFCL condition arises from the commissioning and testing of a REFCL). Under these conditions the Phase-to-Phase voltage variations in Table 22 apply to that part of the 22kV distribution system experiencing the REFCL condition.

**Table 22: REFCL Condition Nominal Voltage Variations**

Voltage Level in kV	Phase To Phase Nominal Voltage Variations			
	Steady State	Less than 1 minute	Less than 10 seconds	Impulse Voltage
22	± 6% (± 10% rural areas)	± 10%	Phase to Phase +20%-100%	150kV peak

The Australian Standard AS 61000.3.100-2011 is also used as appropriate for assessment of steady state voltage limits.

Electricity Safety (Bushfire Mitigation) Regulations 2013<sup>21</sup> introduced on 1 May 2016 require AusNet to install Rapid Earth Fault Current Limiter (REFCL) devices. These devices are to be deployed in high fire risk areas prior to 1 May 2023.

REFCLs reduce energy release in powerline earth faults (fallen wire, tree touching wire, etc.) by rapidly displacing network voltages to bring the voltage on the faulted conductor close to zero. On a 22kV network, REFCL response to an earth fault will very quickly reduce the voltage on the faulted conductor from around 12,700 volts to less than 250 volts. This displacement necessarily causes the phase-to-earth voltages on two un-faulted conductors to increase to 173% (i.e., the square root of three) of their pre-fault level.

### 12.4.2. Power Factor

The EDCoP clause 20.5.5 requires a customer to ensure that the customer's demand for reactive power does not exceed specified limits. These limits are shown in Table 23.

**Table 23: Power Factor Limits**

Supply Voltage in kV	Power Factor Range for Customer Maximum Demand and Voltage					
	Up to 100 kVA		Between 100 kVA-2 MVA		Over 2 MVA	
	Minimum Lagging	Minimum Leading	Minimum Lagging	Minimum Leading	Minimum Lagging	Minimum Leading
<6.6	0.8	0.8	0.8	0.8	0.85	0.85

<sup>21</sup> Electricity Safety (Bushfire Mitigation) Regulation 2013, Version 004, 05/01/2016

6.6 11 22	0.8	0.8	0.85	0.85	0.9	0.9
66	0.85	0.85	0.9	0.9	0.95	0.98

A customer must use best endeavours to keep the power factor of its electrical installation within the relevant range set out in Table 23. AusNet supply policy and connection agreements stipulate these requirements and therefore power factor limits are maintained at most connection points. AusNet uses tariffs on reactive power for its large customers to incentivise compliance.

### 12.4.3. Harmonics

The EDCoP clause 20.6.3, requires the distributor to ensure that the harmonic levels in the voltage at point of common coupling (PCC) nearest to a customer's point of supply comply with the levels specified by the system standards set out in Schedule 5.1a, clause S5.1a.6 of the NER.

Further, subject to clause 20.6.1, a distributor must comply with the system standards set out in Schedule 5.1a, clause S5.1a.6 of the NER, particularly establishment of the 'planning level' by the distributor.

As per the existing EDC, a customer must keep the harmonic currents below the limits specified in Table 24 and otherwise comply at its nearest PCC with IEEE standard 519-1992 "Recommended practices and Requirements for Harmonic Control in Electrical Power Systems". The joint Australian/New Zealand Technical Report TR IEC

61000.3.6.2012 will also be used as appropriate for the allocation of voltage harmonic limits to disturbing loads or generators.

**Table 24: Current Harmonic Distortion Limits**

Isc/IL	Maximum Harmonics Current Distortion in Percent of IL Individual harmonics Order 'h' (Odd Harmonics)					THD
	<11	11≤h<17	17≤h<23	23≤h<35	35≤h	
<20	4.0%	2.0%	1.5%	0.6%	0.3%	5.0%
20<50	7.0%	3.5%	2.5%	1.0%	0.5%	8.0%
50<100	10.0%	4.5%	4.0%	1.5%	0.7%	12.0%
100<1000	12.0%	5.5%	5.0%	2.0%	1.0%	15.0%
>1000	15.0%	7.0%	6.0%	2.5%	1.4%	20.0%

**Notes:**

- Even harmonics are limited to 25% of the odd harmonics listed above.
- Current distortions that result in a DC offset, e.g., half-wave converters, are not allowed.
- \*All power generation equipment is limited to these values of current distortion, regardless of actual ISC/IL.
- Isc = maximum short-circuit current at point of common coupling.
- IL = maximum demand load current (fundamental frequency component) at point of common coupling.

AusNet maintains harmonic voltages within limits at most of its supply points. Harmonic voltages are known to have deviated from the allowable limits at several locations in the network. These instances were observed from analysis of metered data and from customer enquiries. Where harmonic voltage is suspected to be outside limits, it is investigated, and corrective measures are developed.

### 12.4.4. Inductive Interference

The EDCoP clause 20.7 requires the distributor to ensure that inductive interference caused by its distribution system is within the limits specified in AS 2344-2016.

AusNet design standards avoid generation of radio frequency interference (RFI) or Television interference (TVI) on the network. This is mainly achieved by type tested equipment and suitably designed components. In addition, routine cyclic inspections and maintenance procedures ensure that the network is maintained in a good condition to ensure RFI & TVI is not generated or limited to levels that will not affect customers.

### 12.4.5. Load Unbalance (Negative Sequence Voltages)

The EDCoP clause 20.8.1 requires the distributor to maintain the negative sequence voltage at the PCC to a customer's three-phase electrical installation in accordance with the system standard in Schedule 5.1a, clause S5.1a.7 of the NER.

### 12.4.6. Flicker

The EDCoP clause 20.10 requires the distributor to maintain voltage fluctuation at the point of common coupling at a level no greater than the levels specified in accordance with the system standards set out in Schedule 5.1a, clause S5.1a.5 of the NER.

Appropriate flicker allowances are given to customers with disturbing loads prior to supply connection approval.

These allowances are given based on the aforementioned Standards.

There has been report of excessive flicker associated with one HV connected customer in the GNTS 66kV loop, however, assessment conducted by AusNet based on network Power Quality Meter installed the vicinity of customer suggests that flicker levels (both short/long term) were within the code limits. AusNet is continuing the investigation and engagement with the customer to identify the root cause of reported voltage fluctuations<sup>22</sup>.

## 12.5. Performance against quality of supply measures and standards

Outlined in the subsections below is a summary of AusNet performance against the measures and standards.

### 12.5.1. Network Performance – Quality of Supply

As per the EDCoP clause 20.4.7, AusNet monitors and records steady state voltages and voltage variations. The recorded quality of supply performance is reported to the Australian Energy Regulator which publishes it in the form of the 'Victorian Electricity Distribution Businesses – Comparative Performance Report'<sup>23</sup>. Other quality of supply issues is dealt with on an as needs basis according to the EDCoP Clause 25.3.1. Further information on how AusNet manages Quality of Supply issues can be found in Section 12.4. Table 25 shows the network quality of supply performance statistics from the past five regulatory periods.

**Table 25: Summary of Voltage Variations**

Quality of Supply - Voltage Variation	CY20	HY1-2021	FY22	FY23	FY24	FY25
Voltage variations - steady state (zone sub)	1,080	641	1,309	3,312	2,038	2,911

<sup>22</sup> Two specific incidents (two separate dates) were reported by the customer.

<sup>23</sup> A copy of the report can be found at the Australian Energy Regulator's website: <http://www.aer.gov.au/node/483>

<b>Voltage variations - one minute (zone sub)</b>	997	1,354	3,348	2,258	1,885	1,326
<b>Voltage variations - 10 seconds (zone sub) Min&lt;0.7</b>	885	540	1,505	1,423	1,516	1,526
<b>Voltage variations - 10 seconds (zone sub) Min&lt;0.8</b>	1,314	740	2,274	2,227	2,429	2,361
<b>Voltage variations - 10 seconds (zone sub) Min&lt;0.9</b>	2,676	1,478	4,562	5,022	6,621	6,300
<b>Voltage variations - steady state (feeder)</b>	12,334	364	391	287	358	337
<b>Voltage variations - % zone subs monitored</b>	100%	100%	100%	100%	100%	100%
<b>Voltage variations - % feeders monitored</b>	100%	100%	96%	98%	98%	98%

Quality of supply monitoring is becoming increasingly important given the technology shift occurring in the industry, and the corrective action taken or planned to maintain quality of supply within the EDCoP limits are described in the following sections.

### 12.5.2. Network Performance – Voltage Level Reporting

In accordance with clause 19.4.1(e) of the EDCoP, AusNet is required to publish annual voltage level reporting information in the detailed in Schedule 2 of the EDCoP. The aggregated 10-minute-averaged voltage data identified in Table 7 of Schedule 2 of the EDCoP for each calendar year for the past 5 years are published in our website.

### 12.5.3. Network Performance – Voltage Level Reporting Methodology

The methodology used to produce the voltage data and other categories of information is described herein:

- The voltage data published in the CSV file is the 10-minute averaged voltage data over 3 months of the aggregated AMI population of each Voltage Control Section (VCS). The relevant 3-month periods (starting the first Sunday of the month) are as follows:
  - 1 December – 28 (or 29) February (depending on the year)
  - 1 March – 31 May
  - 1 June – 31 August
  - 1 September – 30 November
- The voltage data are populated for four different time bands for each Voltage Control Section over the 3month period. The time-blocks defined in Table 6 of Schedule 1 include the start and end time is inclusive of the hour, which will double count the transition hour. For aggregation of data, the time blocks indicated below are considered to finish one minute before end time (e.g., 10:00-16:00 is considered to be 10:00-15:59).
  - 10:00 – 16:00
  - 16:00 – 22:00
  - 22:00 – 04:00
  - 04:00 – 10:00

- Schedule 2 of the EDCoP defines a voltage control section (VCS) as any device or equipment, which manages the feeder voltage, starting from the zone substation on-line tap changer. Therefore, each feeder comprises of voltage control sections starting from the distribution zone substation and where applicable VCS sections are identified downstream of line voltage regulators and SWER isolating transformers.
- AusNet receives 5-minute instantaneous voltage data from AMI meters. The existing 5-minute instantaneous voltage data (from AusNet Power Quality dataset) are used to derive the averaged voltage data over each 3-month period for each time block for each voltage-controlled section. This method is used because a similar outcome is achieved by averaging the 5-minute instantaneous data as calculating the 10-minute averaged voltage data for each voltage control section over the specified time blocks on 3-month periods.
- In addition to voltage data, standing data on feeders are provided as specified in Schedule 2 of the EDCoP. The standing data used in the voltage report comes from different sources; some are historical (time-bound) and others are current. Therefore, some of the standing data represents the state of the network as at present and some data being correct as of the historical analysis date. The table below details whether a column in the resultant dataset is time-bound or as-is. The customer counts (and customers with small embedded generation) are based on unique NMLs. As the source of customer counts is joined by the analysis date, the counts reflect what it was at the analysis dates.
- The geographical location details of voltage control devices (Column IDs: VCS\_Latitude and VCS\_Longitude) and type of VCS devices (Column ID: VCS\_Type) are also included in the voltage report.

**Table 26: Standing data details**

Column ID	Column Description	Time-bound (historic) data	As-at (current) data
<b>ZONE_SUB</b>	Zone Substation		✓
<b>FEEDER</b>	Feeder		✓
<b>FEEDER_CLASS</b>	Feeder class (urban, short rural or long rural)		✓
<b>VCS_NAME</b>	Name of VCS		✓
<b>BUSINESS_ID</b>	Detailed name of VCS		✓
<b>AMI_CUSTOMERS</b>	Customers with AMI	✓	
<b>AMI_CUSTS_WITH_EG</b>	AMI customers with embedded generation	✓	
<b>PCT_AMI_CUSTS_WITH_EG</b>	Percentage of AMI customers with embedded generation	✓	

## 12.6. Corrective Action – Quality of Supply

At a high level, AusNet aims to maintain sub-transmission network voltages (66 kV) within the EDCoP limits utilising the methods described below:

- Terminal Station transformer on load tap changer (OLTC)
- Terminal Station reactive support
- Line voltage regulators (66 kV)

- Establishing optimum 66 kV voltage set points at each terminal station.
- AusNet the terminal station secondary (i.e. 66 kV) bus voltages were reviewed during 2015 and the setting points were informed to the AEMO as part of the annual reporting requirement. There were no changes from the previous year at the eleven connection points.

At a high level, AusNet aims to maintain distribution feeder voltages (22 kV) within the EDCoP limits utilising the methods described below:

- Zone Substations on load tap change (OLTC)
- Zone substations reactive support
- Line voltage regulators (22 kV)
- Pole mounted 22 kV capacitor banks (typically 900 kVAR at a location)
- Establishing optimum 22 kV voltage set points at each zone substation.
- Distribution feeder voltages are reviewed on an ongoing basis and where necessary adjustments are made to existing line voltage regulators, feeder configurations, capacitors and zone substation voltage set points. The secondary bus voltages (i.e., 22 kV) at a number of zone substations were lowered during the year to cater for increased penetration of solar photovoltaic arrays. AusNet utilises voltage profiles captured by AMI meters to implement optimum distribution feeder voltages.
- AusNet low voltage network voltages (230/400 V) are maintained within the EDCoP limits utilising the methods described below.
- Distribution transformer off-load tap changes
- Upgrading or constructing new distribution substations
- Load balancing
- Low Voltage line augmentation
- Deployment of Dynamic Voltage Management (DVM) This system enhances voltage compliance and solar hosting capacity by dynamically adjusting network voltages in real time, using feedback from AMI smart meters installed at customer premises. The stage-1 commissioning progressively being completed across Five Ausnet's zone substations in 2025/26. The stage-1 has been implemented at five ZSS's including HPK, WGI, BDL, PHI and ELM (pending few works expected in Jan 2026). In the next regulatory period(2027-31) stage-2 will be implemented on additional locations..

## 12.6.1. Voltage compliance corrective action

With the increased penetration of distributed generation, such as solar PV, increasing network voltages and voltage operating bands, AusNet has increased its voltage monitoring capabilities, utilising AMI data, and developed proactive programs to improve voltage compliance and distributed energy resources (DER) integration. As part of voltage management action plan, identified ZSS's with highest voltage constraints (usually higher breach) based on historical data and revised the VRR settings to improve overall network functional compliance. In addition to that the voltage monitoring tool and the three key voltage management and DER integration programs are outlined in the following sections

### 12.6.1.1. Utilisation of AMI data in voltage compliance monitoring and corrective action

In addition to the above traditional methods, AusNet has developed a tool, known as Explore, that uses AMI data and network analytics to monitor the level of voltage compliance within AusNet distribution network. Explore provides an up-to-date view of the level of voltage compliance and stores historical data to give a view of how voltage compliance has changed over time.

The target for 'functional compliance' to the Australian Standard, AS 61000.3.100, is to have less than 5% of customers experiencing voltages outside the 216-253 Volts target range on the low voltage network. Non-compliance has significantly reduced using the AMI data.

The improvement in voltage compliance seen is primarily due to voltage regulator setting changes that have been actively made to improve voltage levels. Many of the regulators were changed from line-drop compensation to uncompensated settings. These setting changes have been made gradually since 2014 to improve voltage levels and allow better integration of embedded generation such as residential solar PV. To improve compliance further by utilising the AMI data, Dynamic Voltage Management (DVM) has also been deployed at 5 historically less-compliant

sites (HPK, WGI, BDL, ELM, PHI). The performance of DVM at these 'Stage 1' sites will be used to inform future stagings of the project.

### 12.6.1.2. Customer supply compliance program

This is a reactive program that addresses quality of supply issues identified by customers within AusNet electricity distribution network. It focuses on taking immediate corrective actions in response to customer complaints.

Where customer issues can be resolved by adjusting transformer tap settings or phase balancing, these are allocated to the appropriate operational cost code and are not included in this program.

- The typical work undertaken under this program includes:
- Upgrading distribution transformers
- Rearranging the network to distribute customers evenly
- Reducing circuit loading by upgrading, or splitting circuits
- Splitting LV networks by installing new distribution substations

### 12.6.1.3. DER Integration technology program

This program addresses the requirements of the technology platform to enable better visualisation, optimisation and orchestration of DER.

Traditionally the most modelling of the network has occurred at higher voltage levels, with little to no analysis being done on the LV network. Uptake of DER and bi-directional flows places an emphasis on the LV network to understand its impact on the upstream network as customers produce and consume electricity.

At AusNet, the power-flow models of the network are currently derived from the geo-spatial system, SDMe, and fed into a power-flow engine, namely Siemens PSS Sincal. Only the 22 kV network data is extracted into the Sincal platform with load data approximated by a manual process involving SCADA measurements and AMI data. Work to automate this process and align to the Common Information Model (CIM) concept is now underway.

The technology program also includes activities on establishment of the foundation required for a future ready forecasting model and a DER Management System as part of the Advanced Distribution Management System (ADMS) upgrade.

The investments proposed in this program of work comprise of the following activities:

- Future Ready Forecasting Model – Enhancement of current Demand Forecasting model, including automation, additional data inputs and inclusion of DER uptake forecast
- HV LV Modelling – Development of the foundation for a HV to LV network load flow model and analytical capability for entire network to enable better planning.
- GIS Network Data Quality Improvements – Work to improve the quality of data in the GIS, to overcome current limitations of SDMe.
- Spatial Application Rationalisation – Work to rationalise existing SAMS and SAMS OPS spatial applications into the SDMe Network Viewer, and repoint downstream interfaces from SAMS and SAMS OPS to SDMe or the Data Lake
- Demand Response Management Enablement – Productionise demand response incentives for residential and DER customers, including payment structures and innovative tariff options.
- Distributed Energy Resource Management System (DERMS) – Work is being undertaken utilising both ARENA funding and network innovation funding to develop DERMS capability that will need to integrate into the ADMS.
- P2P trading – Activities to facilitate AusNet providing meter data to third party trading platforms. This investment includes funding to enable manual data transfer to and from retailers, with data collected and sent via email.

Other power quality related issues are discussed below and how they are maintained within the code limits.

## 12.6.2. Power Factor

Customer connection agreement stipulates the power factor requirement as per the EDCoP.

### 12.6.3. Harmonics

Investigations are carried out where harmonics have deviated from the limits and corrective actions will be instigated where necessary. The zone substation power quality meters (PQM) provide voltage harmonics data. This information shows that voltage harmonics are generally within the code limits except at few zone substations.

### 12.6.3. Inductive interference

By design the generation of radio or TV interference on the network is avoided. This is mainly achieved using type tested equipment and suitably designed components. In addition, routine cyclic inspections and maintenance procedures ensure that the network is maintained in a good condition to ensure RFI & TVI is not generated or limited to levels not affecting the customers.

### 12.6.4. Negative Sequence Voltage

The South Gippsland network has experienced negative sequence voltage issues for some time. AusNet has enhanced power quality monitoring in its network by installation of six new meters in 2025 at below locations:

- MWTS No.1 66kV Bus
- MWTS No.2 66kV Bus
- MWTS No.3 66kV Bus
- GNTS No.1 66kV Bus
- MBTS-BRT 66kV Line
- WOTS No.1 66kV Bus

AusNet will continue to monitor negative sequence voltage across its network and if excessive negative sequence is identified, remediation/s will be proposed to ensure limits set out in NER S5.1 a.7 are not exceeded.

### 12.6.5. Monitoring Quality of Supply

In previous years AusNet fleet of power quality monitors have not been providing sufficient data to meet all of the EDCoP clause 20.4.7 requirements. In 2017 AusNet initiated a project to improve this situation. The scope of the project included upgrading power quality monitoring software, establishing Ethernet/fibre communication to all Zone Substation PQ meters, establishing communication to all Feeder Extremity meters and an automated process for developing Compliance and Business reports.

This project was successfully completed in early 2018. As a result, PQ data is captured from dedicated PQ meters to meet the compliance as per the above clause.

AusNet is continuing trialling a new PQ meter to be used for Feeder Extremities PQ measurements replacing the current EDMI fleet.

Additionally, AusNet is continually developing its AMI meter data analytics to monitor the level of voltage compliance in accordance with AS 61000.3.100.

## 12.7. Processes to ensure compliance with the measures and standards

AusNet strives to ensure compliance with the measures and standards for reliability and quality of supply. The processes AusNet has in place are described in this section.

### 12.7.1. Processes for compliance – Reliability

AusNet monitors its network reliability against the targets set by the AER in the EDPR for the current regulatory control period. Distribution network investments are undertaken to improve network reliability in response to the STPIS incentive mechanism. The reliability focus investments include:

- Distribution feeder sectionalising by installing Automatic Circuit Reclosers (ACR) and Automatable Gas Switches (GS).
- Implementing Distribution Feeder Automation (DFA). Ausnet is upgrading this scheme to a more advanced version, Fault location, isolation, and service restoration (FLISR) scheme.
- Installing Animal Proofing Insulation, particular on distribution pole substations.
- Following an 'S' Factor centred asset management program
- Installing Fuse-savers to minimise fuse operations due to transient events.
- In AusNet reliability improvements is a continuous process. Apart from the specific programs targeting network locations where investments are needed to improve reliability, the ongoing maintenance, inspections, and replacement of deteriorated assets will also contribute to improving network performance.
- In addition to the above mentioned investments, Ausnet has identified 11 Worst Served Feeders where opportunity lies to improve reliability for vulnerable communities. A proposal to improve reliability in these areas is currently under consideration, with implementation planned to commence from 2026.

**Table 27: Feeders proposed for improved reliability**

Area	Feeders
Bendoc	BM8B31
Benalla	BN11
Cann River	CNR1, CNR2, CNR3
Kinglake	KLK11
Murrindindi	MDI1
Moe	MOE13
Mansfield	MSD1
Newmerella	NLA31
Woori Yallock	WYK13

## 12.7.2. Processes for compliance – Quality of Supply

AusNet monitors quality of supply utilising power quality monitors permanently installed at zone substations and feeder extremities as well as AMI data as outlined previously. In addition to these power quality measurements, measurements using portable devices are undertaken to investigate customer complaints on power quality. These unforeseen reactive actions are necessary due to changes in the customer load profile or unexpected localised network loading issues. The actions taken to resolve power quality issues include:

- Distribution feeder upgrades, new feeders, or feeder reconfiguration.
- Distribution substation upgrades or installing new substations.
- Low Voltage network upgrades, reconfiguration, new LV lines or fuse upgrades.
- SWER network augmentations including upgrading or providing new isolating transformers.

## 12.8. Service Target Performance Incentive Scheme Information from the EDPR

Table 28 and Table 29 outline the information on the Service Target Performance Incentive Scheme (STPIS) contained in AusNet the AER's Final Decision for the 2022-26 Electricity Distribution Price Review (EDPR) period.

### 12.8.1. AER's Final Decision on STPIS 2022-26 Electricity Distribution Price Review (EDPR)

**Table 28: AER's Final Decision 2022-26 EDPR AusNet**

AusNet Proposal	AER Final Decision
Cap on revenue at risk of $\pm 4.5\%$	Cap on revenue at risk of $\pm 4.5\%$
MED threshold beta of 2.8	MED threshold beta of 2.8
Proposed performance targets based on its five years historical averages.	The AER accepted AusNet proposal, where AusNet performance targets was based on its five years historical averages.
AusNet proposed a new Customer Service Incentive Scheme, which eliminated the need for the telephone parameter in the STPIS.	The AER accepted our new Customer Service Incentive Scheme where the reward and penalty is capped at $\pm 0.5\%$ . As a result, the telephone parameter was removed from the STPIS calculation.

**Table 29: Performance targets for SAIDI, SAIFI, and MAIFI: 2022-26**

Measure	Feeder Class	RY22	RY23	RY24	RY25	RY26
Unplanned SAIDI	Urban	87.190	87.190	87.190	87.190	87.190
	Rural Short	195.160	195.160	195.160	195.160	195.160
	Rural Long	293.692	293.692	293.692	293.692	293.692
Unplanned SAIFI	Urban	0.891	0.891	0.891	0.891	0.891
	Rural Short	2.007	2.007	2.007	2.007	2.007
	Rural Long	2.628	2.628	2.628	2.628	2.628
Unplanned MAIFI	Urban	2.817	2.817	2.817	2.817	2.817

	Rural Short	5.657	5.657	5.657	5.657	5.657
	Rural Long	9.920	9.920	9.920	9.920	9.920

# 13. Asset Management

This section provides information on AusNet's asset management approach. This includes a summary of AusNet's asset management system and how distribution losses are addressed.

## 13.1. Asset Management System

AusNet's Asset Management System (AMS) is a set of complex processes and interactions to plan and control asset-related activities to realise value from our assets and satisfy the needs of the business and those of our customers and communities. The AMS is certified to ISO 55001:2014 Asset management – Management systems – Requirements and is informed by the Global Forum on Maintenance & Asset Management (GFMAM) Asset Management Landscape v2.0.

## 13.2. Scope of the Asset Management System

The scope of the AMS includes all assets providing network services to customers as identified in the Electricity Distribution Licence issued to AusNet Electricity Services Pty Ltd by the Essential Services Commission.

The following functions are included in the scope of the AMS:

- Creation and acquisition of assets.
- Commissioning of assets.
- Operation of the network.
- Inspection and maintenance.
- Repair, refurbishment and replacement of assets.
- Decommissioning, removal and disposal of assets.

The AMS includes all employees, Delivery Partners and Service Providers undertaking activities on AusNet's network. Where appropriate, the AMS includes linkages to human, financial and intangible assets necessary for the holistic management of the network assets to meet the objectives of the AusNet corporate strategy.

## 13.3. Asset Management Framework

The asset management framework shown in Figure 15 provides a summary view of the key artefacts and processes that comprise the AMS.

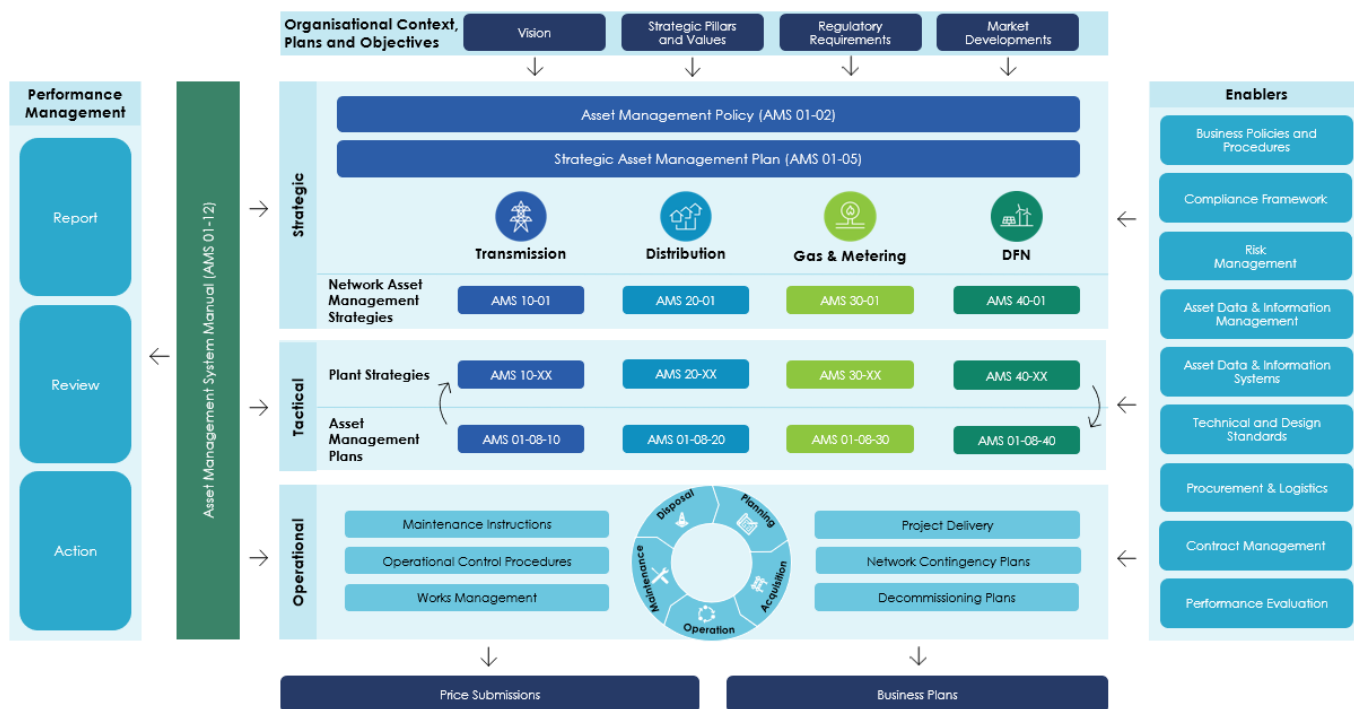

**Figure 15: Asset Management Framework**

AusNet’s organisational context, plans and objectives inform the Asset Management Policy which then sets the direction for the Strategic Asset Management Plan (SAMP) and the setting of asset management objectives. The SAMP and asset management objectives are cascaded to the lines of business Asset Management Strategies, which provide a bi-directional influence through feedback and refinement to the SAMP.

The Lines of Business Asset Management Strategies guide the creation of Plant Strategies for each asset class. The output of the above strategies results in the development of the five-year Asset Management Plans (AMPs). The AMPs identify the required programs of work and drive operational decision-making through the asset lifecycle. The outcomes of the AMPs provide a feedback loop to the higher strategies. A range of enterprise functions enable these processes. A performance management approach enables appropriate action to be taken to address nonconformities and identify improvement opportunities.

## 13.4. Asset Management Methodology

AusNet is focused on delivering optimal distribution network performance at efficient costs. Except in the case where outputs are mandated, this requires an explicit cost benefit analysis to be undertaken in order to assess whether the overall economic value of expenditure is positive.

In doing this, AusNet assesses the incremental costs of delivering an incremental change in network performance to customers, relative to the incremental benefits accruing to customers from the delivery of that enhanced network performance.

The asset strategy ensures that all decisions to augment, replace, or maintain network assets are justified on economic grounds. The benefits are a function of the explicit customer value proposition, or proxy via the adoption of minimum performance standards, which are stipulated in legislation or other statutory or regulatory instruments.

The various drivers that are brought to bear when undertaking AusNet Cost Benefit Analysis are summarised in Figure 16.

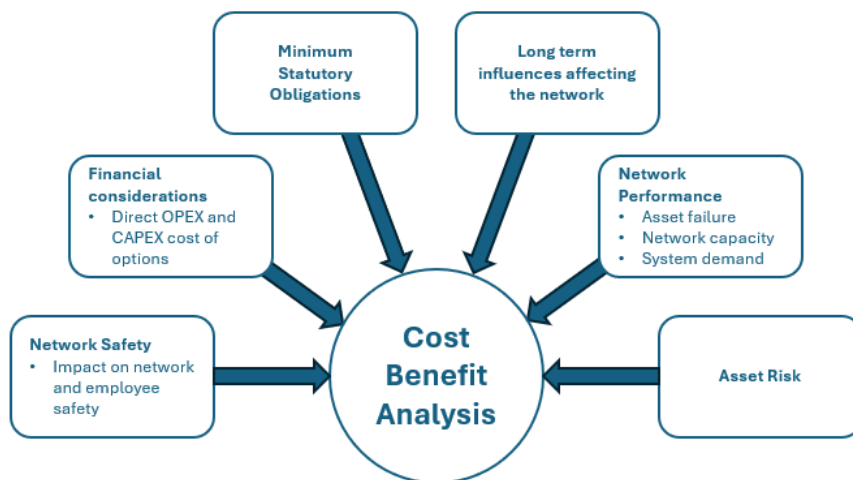

Figure 16: Cost Benefit Analysis Drivers

The annual review of the various drivers and the outcome of cost benefit analysis is documented in the AMP.

## 13.5. Key Asset Management Strategies

A list of the current Asset Management strategies for the electricity distribution network is attached in Appendix B: Asset Management Strategy Reference.

In the current low demand growth environment, the key strategies affecting the forward works program are the Distribution Asset Management Strategy, The Enhanced Network Safety Strategy and the individual plant strategies. Additionally, AusNet is required to maintain the Rapid Earth Fault Current Limiting (REFCL) technology during Total Fire Ban days.

The Enhanced Network Safety Strategy describes opportunities to develop and implement network asset management initiatives and programs that continuously reduce network related health and safety risks 'as far as practicable' (AFAP) for customers, public and personnel, in line with the requirements of the Electricity Safety Act 1998. This incorporates AusNet aspiration to reduce serious incidents through successive regulatory periods.

The individual plant strategies describe how AusNet intends to focus on stabilising failure trends and risk trends. In particular, the emphasis is on stabilising equipment failure trends over time by matching replacement rates to the deterioration rate of those assets nearing the end of their effective service life.

Consistent with amendments to the Electricity Safety (Bushfire Mitigation) Regulations 2023<sup>24</sup>, introduced on 1 May 2016, with recent update coming into effect on 16 June 2023, AusNet has implemented REFCL technology in 22 nominated zone substations.

### 13.5.1. Electricity Distribution Network Asset Management Strategy

The Electricity Distribution Network Asset Management Strategy is the overarching strategy guiding and directing the plant strategies and other asset management decision making. It provides a link between the asset management objectives, and AusNet's Distribution Network Objectives. The AMS is central to AusNet's processes for delivery of network services to customers safely and reliably in accordance with AusNet's Asset Management Policy. It provides authoritative guidance for the development of the asset management works programs and provides contextual information for the asset strategies that will enhance the skills, resources and knowledge employed at AusNet, and thereby facilitate efficient network development and asset management.

### 13.5.2. Enhanced Network Safety Strategy

<sup>24</sup> Available: <https://www.legislation.vic.gov.au/as-made/statutory-rules/electricity-safety-bushfire-mitigation-regulations-2023>

The Enhanced Network Safety Strategy describes the safety related risks apparent on the network and the program of economically justified work that is intended to meet the regulatory obligation to reduce risk AFAP.

The key risks arise through asset failures resulting in the risk of electrical shock and fire ignition. The risk of ground fires which occur in densely populated, heavily vegetated areas in extreme weather conditions is of particular significance as there are major consequences that can result from these fires.

Modelling of the risks associated with the failure of some classes of assets such as cross-arms, poles and conductor has been completed using a fire loss consequence model. This model assists in identifying the economic volume of asset replacements and the location of the assets which present the greatest risk.

Several programs of work arise from the analysis and modelling.

These programs result in one of the following actions:

- Replacement of deteriorated assets in specific areas (in some cases the consequence of asset failure is so great that the replacement of an asset is 'brought forward' so that the asset does not reach a state of advanced deterioration before it fails); and
- Programs to prevent external factors impacting the network such as fitting animal and bird proofing to complex high voltage overhead structures to reduce the risk of fire ignition due to animal and bird impact.

### 13.5.3. Plant Strategies

Plant Strategies contain information on activities performed by AusNet for economic life cycle management of assets. AusNet maintains a risk management system designed in accordance with AS ISO 31000 Risk Management – Guidelines to maintain asset risks, providing greater certainty for the owners, employees, customers, suppliers, and the communities in which we operate.

The risk of each asset is calculated as the multiplication of probably of failure (PoF) of the asset and the consequence of failure (CoF). The risk can be calculated per year or over an extended period of time and converted into present value.

In the distribution network, AusNet aims to maintain risk. Risk treatments required to achieve this over time include replacement, refurbishment, monitoring and maintenance activities, and are developed based on forecasted risk. The overall approach to quantified asset risk management is detailed in AMS 01-09. Sections 4 to 6 of AMS 01-09 discuss the considerations and methodologies to determine PoF, CoF, and risk treatments that are unique to individual asset classes.

Risk treatments maintain risk by targeted reduction of PoF or CoF. For example, targeted replacements of deteriorate assets (like for like) reduces forecasted PoF. Treatment measures include asset replacement, asset refurbishment, inspections, testing or system redesign, and are achieved through capital projects or operational expenditure. Risk treatment options are described in the section on 'Risk Treatment' in AMS 01-09.

Capital replacement is a major component of asset risk management. The prerequisites for replacing assets:

- replacement of an asset will result in a material risk reduction
- risks can't be feasibly managed through maintenance or refurbishment
- monetised risk exceeds the replacement cost – ie replacement is economic.

### 13.5.4. Rapid Earth Fault Current Limiter (REFCL) Implementation

A REFCL is electrical protection technology being installed to reduce the risk of fire ignition associated with phase to earth faults on the 22 kV network.

A REFCL operates when a single phase-to-earth fault occurs. Its operation causes the phase voltage of the faulted phase to be reduced to near earth potential (zero volts), thereby working to eliminate the flow of fault current. This compensation also results in phase to ground voltage rise from a nominal 12.7 kV to 22 kV on the un-faulted (healthy) phases, adding more stress to assets on the medium voltage network.

The location and timing for implementation of the REFCL technology is prescribed in Schedule 2 of the Electricity Safety (Bushfire Mitigation) Regulations 2013.

The Bushfire Mitigation Regulations stipulate three Tranches with delivery due by the first of May in the years 2019, 2021 and 2023. All REFCL are now installed as per the Regulations and is illustrated in Figure 17.

Further information may be found on AusNet website<sup>25</sup> and in AusNet Bushfire Mitigation Plan – Electricity Distribution Network<sup>26</sup>

The Victorian government information on REFCL deployment can be found at the Department of Environment, Land, Water, and Planning (DELWP) website<sup>27</sup>.

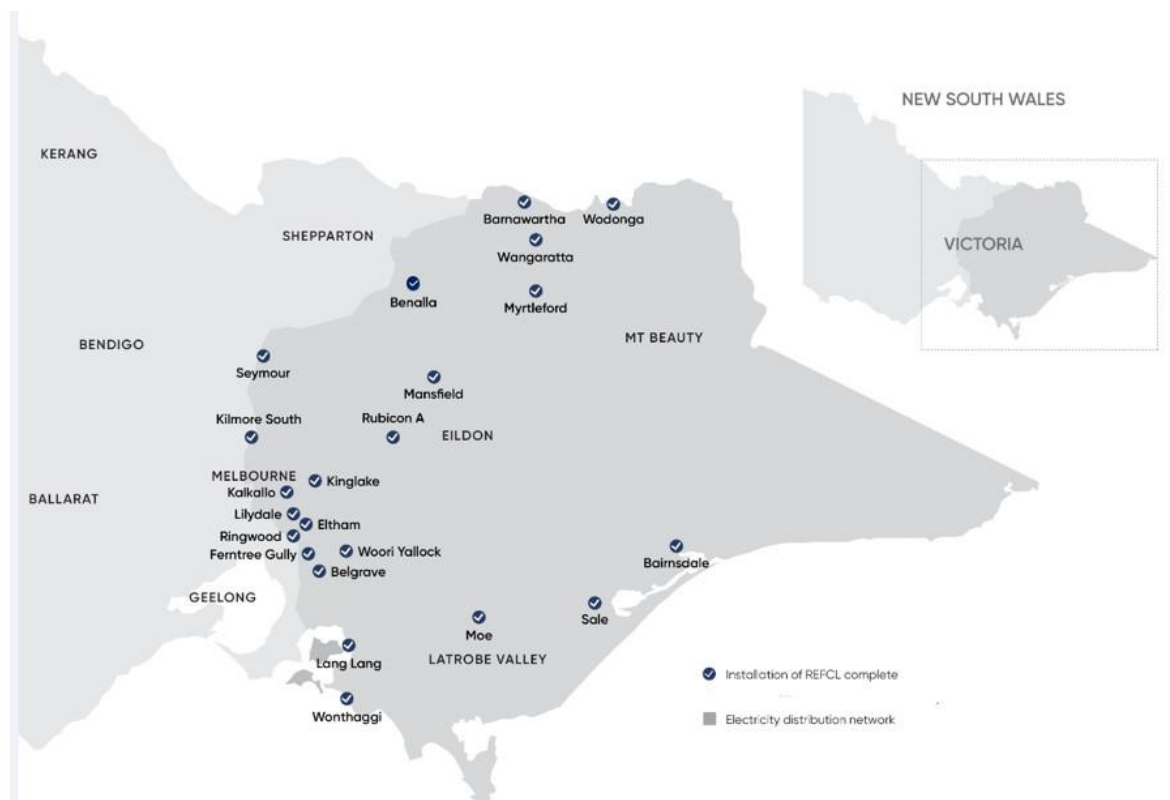

Figure 17: REFCL Location and Delivery Timetable

## 13.6. Distribution losses

This section provides details required by Schedule 5.8 (k) (1A) of the NER v.200, and explains how AusNet accounts for the cost of distribution losses. Clause 19.2(b) of the EDCoP issued by the ESC states:

“A distributor must use best endeavours to:

.....

(b) develop and implement plans for the acquisition, creation, maintenance, operation, refurbishment, repair and disposal of its distribution system assets and plans for the establishment and augmentation of transmission connections... to minimise the risks associated with the failure or reduced performance of assets; and in a way which minimises costs to customers taking into account distribution losses.”

In the EDCoP, the terms:

<sup>25</sup> <https://www.ausnetservices.com.au/about/community/powerline-bushfire-safety-program/rapid-earth-fault-current-limiter-program>

<sup>26</sup> AusNet, Bushfire Mitigation Plan – Electricity Distribution Network. Available: <https://www.ausnetservices.com.au/-/media/project/ausnet/corporate-website/files/about/regulatory-publications/bfm-10-01-admin-update-afdrs-v28-nov-22.pdf>

<sup>27</sup> <https://www.energy.vic.gov.au/safety/powerline-bushfire-safety-program/safety-devices>

'Distribution losses' means electrical energy losses incurred in distributing electricity over a distribution system.

'Distribution system' in relation to a distributor, means a system of electric lines and associated equipment at nominal voltage levels of 66 kV or below.

Further, NER Chapter 5, clause 5.17.1 (c)(4)(vii) requires changes in electrical energy losses to be considered in the RIT-D.

In compliance with these obligations, AusNet considers network losses in planning and development of distribution assets.

AusNet fully accounts for the economic value of reductions in system losses (or increases if this were the case) in the economic assessment of augmentation and asset replacement projects. This is achieved through the following analysis:

- Network power flow studies are used to determine the change in MW system losses both before and after project implementation at maximum demand.
- A load loss factor of 0.4 (ratio of losses at average demand to losses at peak demand) is applied to determine average network losses.
- This is multiplied by 8,760 hours per annum for network projects to determine energy savings per annum from network losses reduction. For network support options such as generation the expected annual hours of operation are used in the calculation.
- This is multiplied by \$45 to provide an annual economic benefit for the reduction in system losses associated with project work. A figure of \$45 represents typical cost of electricity but is a higher end figure to account for the fact that losses are proportional to the square of the load and are much higher at higher demands. This figure will be escalated by the square of the load growth to reflect the relationship between network losses and load growth.
- This economic benefit is included in Net Present Value analysis to determine projects options that deliver the highest overall economic benefit. Issues that may impact on system limitations identified through asset management.

Issues, including those that impact on system limitations, are identified through the Asset Management System and the planning process mentioned in the previous sections.

## 13.7. Further information on Asset Management

Further information on the asset management system, asset management strategies, and the methodology adopted by AusNet may be obtained by contacting the listed representative in the Disclaimer at the beginning of this report.

# 14. Demand Management Activities

Schedule 5.8 (l) of NER addresses demand management activities undertaken on the AusNet network. Since 2012 when AusNet embarked on a strategy to strengthen its Demand Side Participation (DSP) capability, AusNet has undertaken several Embedded Generation and Demand Management (DM) activities.

AusNet Network Innovation team conducts trial projects, analyses options and provide input to network planning processes. The Network Planning and Grid Evolution teams are responsible for the Demand Management portfolio and consider deployment of embedded generation and non-network solutions as part of the network planning process.

In addition, Under Frequency Load Shed (UFLS) targets by AEMO, to load shed at least 60% of the 'total power system load' (NER clause 4.3.1(k)) in event of significant multiple contingencies is becoming a challenge for distribution networks given the strong uptake of DER. The UFLS is now an area of focus for DNSPs, AEMO and jurisdictional Governments to ensure ongoing power system security. AEMO and DELWP are having regular DNSP engagements for investigation of short, medium and long-term solutions at 66kV and 22kV level to manage UFLS.

The Industry Engagement Strategy aims to facilitate co-operative engagement in network planning between DNSPs and proponents of non-network solutions and is published on AusNet external website<sup>28</sup>.

## 14.1. Non-Network Solutions

The following non-network solutions were deployed by AusNet in the past year:

1. Mobile generation: Temporary generation was installed to manage residential summer peak demand in Euroa and Kalkallo. Outside of the summer months, generators were deployed to reduce the impact of planned outages to customers during asset replacement and augmentation works.
2. Demand Management (DM): A portfolio of commercial & industrial (C&I) customers has been maintained over the past few years, particularly on feeders with emerging summer peak demand constraints.
3. Stand Alone Power Systems – Tranche 1: In 2021, tender submissions were requested for a first tranche of stand-alone power systems (SAPS) to supply fringe-of-grid customers. The target areas were selected based on high ongoing OPEX, avoided replacement CAPEX and to improve reliability of supply to these customers. All 17 sites from Tranche 1 were commissioned in early 2023.
4. Network Support Agreement (NSA): Three NSAs have been executed for 3rd parties to provide demand support via either embedded generation or battery storage facility. These include 7MVA support for DRN 22kV feeder, 3MVA for WGL 22kV feeder, and 5MVA for PHI 22kV feeder.

Prior to each summer, feeders forecasted to reach thermal overload in all three regions were analysed for C&I DM potential. Areas of network with contingency risk were also analysed. Large C&I customers were contacted to gauge their interest in providing demand management services across the summer period. Through ongoing engagement and re-contracting efforts, AusNet has successfully expanded its C&I demand reduction portfolio to approximately 9 MW across the three regions. This increase reflects the return of several customers who had previously opted out of the program but have re-engaged following targeted outreach and strengthened collaboration initiatives.

GoodGrid CPD is an ongoing Critical Peak Demand tariff that is a default arrangement for our large commercial and industrial customers. It incentivises them to reduce energy demand on 5 days of high demand per summer.

<sup>28</sup> A copy of the Industry engagement guidelines can be viewed at AusNet Services' website: <http://www.ausnetservices.com.au/About+Us/Regulatory+Publications.html> A copy of the Industry Engagement Strategy can be viewed at AusNet website: <http://www.ausnetservices.com.au/About+Us/Regulatory+Publications.html>

## 14.2. Key issues arising from applications to connect embedded generation

The key issues identified during the connection enquiry stage were:

### **Emergence of New Technologies**

Inverter-based loads are increasingly common in the market, requiring the development of new processes, commissioning guidelines, and technical standards to ensure stability and compliance.

### **Need for Updated Processes for Sub-5MW Projects**

A growing number of smaller projects (less than 5 MW) connecting at the same point of connection is creating complexity. This demands a review and refinement of the current Sub-5 assessment process to address these newer challenges effectively.

### **Commissioning and Compliance Framework**

While system and process improvements have been made since 2022, there is still a need to establish clear commissioning guidelines for emerging technologies to maintain grid reliability.

### **Proponent-Driven Delays**

Time taken by proponents to complete system studies and provide necessary documentation remains a significant factor impacting timelines.

## 14.3. Actions taken to promote non-network proposals

Since 2021, a range of actions have been undertaken to promote non-network solutions within the AusNet distribution network, including:

### **14.3.1. Non-Network Opportunities**

In early 2021, AusNet assessed proposals from service providers for the Phillip Island Non-Network Solution. A 5 MW / 10 MWh battery energy storage system (BESS) was commissioned in 2023 under a Network Support Agreement. This BESS continues to perform as intended, providing peak demand support and eliminating the need for temporary diesel generation during periods of high load.

AusNet also implemented a West Gippsland Non-Network Solution at Longwarry to address a forecast thermal constraint on the 22 kV feeders out of the Warragul Zone Substation. A network support agreement was executed, and a BESS was commissioned in February 2023. The Longwarry BESS is delivering reliable support to both feeder and upstream zone substation capacity during peak demand periods, effectively reducing network loading and improving supply security for the Drouin, Bunyip and Longwarry precincts.

Both battery systems are performing as expected and readily available to support the network whenever required.

The business will continue to promote non-network opportunities on the AusNet website [Non-Network Opportunities \(ausnet.com.au\)](https://ausnet.com.au/non-network-opportunities) and direct requests for proposals to providers listed on AusNet Industry Engagement Register.

### 14.3.2. Grid-Connected Microgrids for Energy Resilience, SAPS and Battery Energy Storage Systems (BESS)

Due to the bushfires in the 2019/2020 summer and the drive to reduce network operational costs, AusNet investigated opportunities for SAPS to improve network resilience. A first tranche of SAPS was commissioned in May 2023 which included 17 SAPS each with one customer connected. This is still the number of regulated SAPS in AusNet's network, i.e. 17 SAPS and total of 17 customers connected to SAPS.<sup>29</sup>

In addition to the residential SAPS rollout, AusNet is trialling their use as independent backup systems for remote telecommunications infrastructure. This initiative supports a broader network resilience strategy, aiming to strengthen supply for critical service providers, maintain customer service continuity during extreme weather events, and mitigate health and safety risks.

Grid-connected microgrids are also being assessed for suitability across the network, similar to the MAGS system at Mallacoota. SAPS, BESS and Grid-Connected Microgrids will be a feature of future planning opportunities and assessed based on suitability, safety, reliability, resiliency and economics in-line with any regulatory changes.

### 14.3.3. Battery Energy Storage Systems (BESS)

AusNet distribution network is experiencing strong growth in residential solar uptake which resulted in increasing challenges such as limited solar hosting capacity and maintaining voltage compliance. In the meantime, maximum demand is expected to continue to grow due to electric vehicle and electrification. The Network is facing the challenge of balancing the grid, when solar energy production is high and demand is low during the day, and then drops off as demand peaks in the evening, i.e., the duck curve.

Ten LV pole-mounted Battery Energy Storage Systems (BESS) are being installed and commissioned during 2025 and early 2026. These BESS are deployed as an alternative solution to traditional network augmentation. They are being installed at high solar penetration areas of the network, with the purpose of managing excess solar export, reducing peak demand and regulating voltage on the LV network. It will also deliver direct benefits to customers, such as relieving export limits and enabling more solar connections. Being the first of its kind project, the trial will help to identify optimal business model for network batteries to maximise customer and network benefits, and provide an evidence base to support network batteries for future full-scale roll out.

In 2024, AusNet kicked off another project to install two ground-mounted BESS at two critical water utility sites in regional Victoria, with commissioning expected by late 2026. These larger BESS will serve as backup energy systems during unplanned power outages, and provide network support during periods of peak electricity demand.

### 14.3.4. Battery Tariff

The Battery Tariff Trial focuses on developing and implementing new tariff structures to optimize the integration and operation of Community Batteries and Battery Energy Storage Systems. These tariffs include two for Neighbourhood Batteries and two for BESS, designed as two-way time-of-use (ToU) tariffs with specific pricing mechanisms for import/export and demand charges. The tariff enables customers to interact with the market, allowing retailers to request and transition customers onto these tariffs while ensuring accurate data aggregation and billing. The key objective is to gather insights into peak loads and excess solar generation during midday for effective battery charging and discharging, paving the way for new tariff structures. This initiative supports managing future peak demand growth, addressing minimum demand voltage and thermal issues, and minimizing or deferring network augmentation, aligning with AusNet's commitment to innovation and demand management in the EDPR framework.

### 14.3.5. EV Tariff Trial

The EV Tariff Event Management Trial is designed to explore direct incentives as a mechanism for managing maximum and minimum demand on the network. The trial enables AusNet to call upon EV customers during high-demand days to curtail charging or on low-demand days to increase charging within predefined periods. Participants are rewarded based on their response from their baseline during these events, fostering engagement while helping to manage network load. Insights from the trial will support the development of future tariff structures, helping to manage future demand, minimize network augmentation, reduce costs for customers, and enhance grid

<sup>29</sup> The final regulatory framework for SAPS in Victoria was brought in in July 2024. Prior to that, these SAPS were unable to be classified as regulated SAPS. <https://www.legislation.vic.gov.au/in-force/statutory-rules/national-electricity-victoria-regulated-stand-alone-power-systems/001>

reliability, particularly during minimum and maximum system load periods. This initiative aligns with AusNet's broader commitment to innovation in demand management and the energy transition.

## 14.4. Plans for non-network solutions over the forward planning period

AusNet Service Services will engage with network support providers over the forward planning period in compliance with the RIT-D test for augmentations greater than \$7M and at other times as required. AusNet has published on its public website an Industry Engagement Strategy and maintains the Register.

For traditional network augmentation projects with an estimated capital expenditure less than \$7 million, AusNet will continue to evaluate the suitability of non-network alternatives and publish Requests for Proposals to service providers listed on the Industry Engagement Register as requirements are identified.

AusNet Service's Industry engagement guidelines<sup>30</sup> facilitates co-operative engagement in network planning between DNSPs and proponents of non-network solutions. This document describes the processes by which AusNet will identify potential non-network, demand-side participation measures and engage with service providers on a case-by-case basis to consider non-network options in its asset management strategy.

In addition, as part of its broader demand management strategy, AusNet is actively monitoring network constraints and prioritising areas where non-network solutions offer a more cost-effective alternative to traditional augmentation. In 2025, AusNet published six non-network opportunities on its website to help relieve network constraints. A wide range of solutions, such as load curtailment, generation export, and other flexible services, are being considered to enhance network support and improve asset utilisation. Relevant information is published on AusNet's website and shared with proponents of the demand management stakeholder register, with regular updates to ensure transparency and accessibility for all interested parties.

Demand-side or non-network service providers are encouraged to contact AusNet where they believe they can deliver a valuable network support service.

AusNet will continue to:

- Maintain a web page where providers of non-network solutions can view AusNet approach to Industry Participation.
- Encourage Industry service providers to contact AusNet where they believe they can deliver a valuable network support service via a non-network solution. Providers are added to AusNet Industry Engagement Register.
- Maintain the portfolio of commercial and industrial demand management customers for availability during the summer period. The portfolio is reviewed annually in response to changing network conditions and customer demand management performance data. The program will continue to enlist customers that are supplied by constrained feeders with 10% POE or 50% POE risk in the short (1-3 years) or supplied from zone substations that are forecast to carry energy at risk under an N-1 contingency.
- Engage commercial and industrial customers on demand-based tariffs, e.g., customers with an annual consumption greater than 160 MWh that are on tariffs with a critical peak demand (CPD) component. This CPD charge provides a significant pricing signal to customers to reduce the demand over five nominated critical peak demand days during the summer period (1 December to 31 March). The response to this incentive has improved and this is expected to continue.
- Utilise future Demand Management Innovation Allowance funding to build additional demand management capability, tools and techniques, focussing on residential customer demand management that may be deployed in urban growth corridors and remote communities.

<sup>30</sup> A copy of the Industry engagement guidelines can be viewed at AusNet Services' website: <https://www.ausnetservices.com.au/about-us/network-regulation/regulatory-publications>

## 14.5. Embedded generation enquiries and applications

As per schedule 5.8 (l)(2) the below information is included. AusNet supports customers wishing to connect embedded generators to our electricity distribution network. The information Table 30 covers the connection of embedded generators connections >1.5MW.

**Table 30: Information on establishing or modifying connection for embedded generation**

2024/2025* Embedded Generation - >5MW	North	East	Central	Total
(i) Connection enquiries received under clause 5.3A.5	3	3	0	6
(ii) Applications to connect received under clause 5.3A.9	0	0	0	0
(iii) The average time taken to complete applications to connect (months)	*			25*
2024/2025 Embedded Generation –1.5MW – 4.99MW	North	East	Central	Total
(i) Connection enquiries received under clause 5A.D.2	1	4	1	6
(ii) Applications to connect received under clause 5A.D.3	5	8	0	13
(iii) The average time taken to complete applications to connect (months)	-	-	-	19*

\*Applications are still active and therefore the time to complete is not currently available

\* Data is collected from 21/11/2024 to 01/12/2025

\* The average time taken includes time when application is on hold or awaiting applicant's response

Ausnet maintains and publishes a register of completed embedded generation projects under Clause 5.18B and Clause 5A.D.1A of the NER. The register can be found at:

<https://www.ausnetservices.com.au/-/media/project/ausnet/corporate-website/files/renewable-solutions/industry/5000kw-or-greater/2025-register-of-completed-embedded-generation-projects-15mw.pdf?rev=51b5c13830674f8794c670feac6205f9&hash=59DBF6DFCA64E49E533AB2E2ABD278D2>

# 15. Information Technology and Communication Systems

This section presents an overview of AusNet investments in information technology and communication systems, as required under schedule 5.8 (m) of the NER.

## 15.1. Priorities and expenditure in the current regulatory period

In the current regulatory period (2022-2026), AusNet seeks to deliver on key strategic enablers with evolving customer expectations at the centre of these developments. Driving better outcomes for customers that are aligned to their expectations is the central focus of technology investments, which is balanced with value delivery through lower costs and effectively managed risk.

For the current regulatory period, AusNet proposed investments in technology are divided into thirteen programs of work, with each program grouped into one of the following five work stream themes:

- Distributed Energy Resources (DER)
- Intelligent Operations
- Cyber Security
- Lifecycle
- Metering

The five work stream themes, and thirteen programs of work are summarised in sections 15.1.1 to 15.1.5

### 15.1.1. Distributed Energy Resources (DER)

DER uptake is increasing on AusNet's distribution network; digital enabling technologies is required alongside traditional network augmentation to integrate DER efficiently and support increased customer choices.

#### 15.1.1.1. Integration of DER

In accordance with a new licence condition to deliver the Solar Emergency Backstop (SEB) AusNet implemented the capabilities required to meet compliance with the licence condition, providing a mechanism to remotely curtail or interrupt customer solar, where required, to maintain system security. As of October 2024, AusNet has implemented all minimum regulatory requirements under SEB.

Below is a summary of the activities under the new Emergency Backstop Mechanism:

- No MSL or deliberate interruption or curtailment of electricity generation was carried out in 2025. During initial commissioning, AusNet has run tests to verify that the device is capable of responding correctly to controls and has planned testing of devices in upcoming years.
- As of 2025, 996 solar customers were connected as emergency backstop enabled during 2024. This reflects approximately 7 MW of connected solar capacity that was connected as backstop enabled.

When referring to backstop enabled systems, we are referring to systems that are connected with the approved emergency curtailment capability. However, at times, systems will lose connectivity with AusNet's network and utility server, in which case that are unable to be curtailed.

We will seek to roll out further enhancements to this functionality as a foundational platform for DER enablement and Distribution System Operation (DSO) capabilities across future years. We are targeting rolling out flexible exports to all new residential customer connections by 1 July 2026. Further enhancements will support the rollout of additional flexible services, to meet the evolving needs of the electricity network and support efficient network investment decisions through dynamic operating envelopes and demand flexibility.

### 15.1.1.2. Future Distribution Network Management

As the network continues to evolve, core technology platforms must support, orchestrate, and manage the growth in DER. There is also rising customer expectations for improved network performance, service delivery, reduced outages, quicker supply restoration, and smart control/integration and information systems, as well as the ability to proactively manage customer demand.

This program of work will ensure AusNet has the network management capabilities required to be able to meet expected demands and customer expectations. AusNet is achieving this through the inflight, multi-phase, Advanced Distribution Management System (ADMS) program to implementing the required technology platform and capabilities.

The execution of Phase 2 of this program has continued in 2025, with the digital capabilities for Fault Location, Isolation and Service Restoration (FLISR) successfully implemented and further work underway to operationalise protection controls. Additionally, we have completed the design phase for the next tranche of ADMS program improvements, including progression of mobile switching (which will continue in 2026) and the implementation of necessary digital performance and hardware upgrades to support the program.

### 15.2.1.3. Customer Information Services

This program will enable AusNet to better track and understand evolving interactions with our customers as the network is increasingly used for two-way energy flow. Implementing an effective Customer Information Management solution will enable AusNet to provide appropriate advice and manage the range of customers and interactions required. This will also ensure the business is well placed to meet regulatory rule changes, which increasingly require sophisticated data management capabilities.

Building on the Customer Self-Serve and Digital Customer Experience projects completed to date, AusNet has successfully launched a new customer connections portal (EnergyConnect), consolidating energy connection request process into a single platform. Additionally in 2025, we have completed data upgrades to improve outage response communications and commenced work on consolidating and simplifying our other customer connection portals (MyHomeEnergy, Public Lighting Portal, etc) to improve end-to-end process flow and user experience.

In response to the February 2024 storms, and to remain consistent with Victorian Essential Services Commission Enforceable Undertaking, we have also completed delivery of improvements to the performance and reliability of AusNet's Outage Tracker communications platform to withstand loads expected in the event of network wide storms.

## 15.1.2. Intelligent Operations

Many advanced sensors and smart meters create valuable sources of data that can be leveraged by the business to improve network reliability and efficiency while reducing customer bills. There is a need to continue enhancing the use of data to improve grid availability, security, and DER integration. This work stream aims to balance the risks to asset and network reliability with the cost of managing those risks through improved data and analytics, automation, visualisation, modelling, and risk management.

### 15.1.2.1. Information Management

AusNet will continue to extend the Information Management platform to develop the capability to analyse network performance, supported by advanced automation on near real time data. This will support better decision making, more efficient operations and network reliability.

In 2025, AusNet has continued to strengthen our digital capabilities through the standardisation of robotic process automation, early testing of AI functionality, and improvements to data structure integrity and efficiency. Additionally, issues reported by councils regarding inaccuracies and formatting in AusNet's public lighting billing system have now been resolved.

### 15.1.2.2. Outage Management

The business will integrate the various sources of asset, maintenance and interconnectivity data required to plan outages and augment the network. This program will simplify outage management, providing field crews with automated reports and live data dashboards, while supporting network controllers with advanced automation and analytics.

The implementation of the ADMS program and associated field mobility capability improvements will contribute to the target outcomes of this program of work.

### 15.1.2.3. Workforce Collaboration

As employees progress within the organisation, they acquire knowledge, which is specialised to the company's operations, structure, and culture. This program will make these unique insights more readily accessible regardless of workforce location or business area, creating productivity gains.

To support the transition of the Distribution field works delivery partner, data interconnectivity upgrades were successfully delivered to enable the migration from Downer to Zinfra. The ICT program implemented for this migration will support enhanced field mobility capabilities and improve fault visibility, and improved data flow integration, and operational management.

### 15.1.2.4. Corporate Enablement

AusNet runs multiple enterprise applications to support day-to-day operations. The enterprise application landscape and related integrations underpin the continuity of all operational processes. As such, AusNet must ensure these core functionalities are adaptable in an increasingly changing environment, while also being robust and reliable solutions for all employees

To maintain system currency and security, and to provide an enabler for improved business processes, AusNet has successfully completed its Enterprise Resource Planning (ERP) suite migration onto a modern and supported platform. Building upon this foundation, focus has now shifted to further driving organisational efficiencies through the optimisation of this new ERP platform.

## 15.1.3. Cyber Security

This work stream aims to balance risks and costs of protecting the distribution network, and customer and business information and assets through improvements in cyber security capabilities.

### 15.1.3.1. Cyber Security

Investment in cyber security in the forecast period will ensure compliance to current and emerging regulations, including sufficient investment to comply with the regulatory obligations under AEMO's Australian Energy Sector Cyber Security Framework (AESCSF). This will provide better protection of critical assets required to supply energy to customers, better protect critical customer and operations data, and support ongoing development and measurement of cyber security capabilities within the organisation.

In 2024 AusNet achieved AESCSF Security Profile 2 (SP-2) compliance. This was achieved following key cyber security upgrades including uplift of identity governance for critical applications, refreshing end-of-life firewalls, migration of web security controls, and uplifting digital asset management of critical applications and dependencies.

The cyber security program will continue to progress towards AusNet achieving target SP-3 maturity (AESCSF's highest rating) relative to the latest Version 2 framework, thereby reducing our key risks. Key initiatives planned include Operational Technology threat & vulnerability management, enhancements to security operations centre technology and practices, uplift in cloud security technology and practices, uplift our data protection technology and practices, and further uplift in cyber security policies and procedures.

## 15.1.4. Lifecycle

This work stream aims to efficiently manage the risks and costs of maintaining core systems resiliency by undertaking prudent lifecycle refreshes.

### 15.1.4.1. Technology Asset Management (TAM) - Applications

AusNet has approximately 200 systems that require periodic patching and enhancements, as aligned to the standard technology lifecycle. This ensures ongoing vendor support, application of performance and security patches and bug fixes, limits downtime and ultimately underpins reliability of critical operations across the business.

Technology Asset Management Applications upgrades are prioritised and implemented annually, based on risk criticality. Key technology initiatives delivered in 2025 include the migration of all user devices to Windows 11,

enhancements to the payroll system to meet updated regulatory requirements, and on-premises database modernisation.

#### 15.1.4.2. Technology Asset Management (TAM) - Infrastructure

Technology infrastructure comprises the hardware, software, network resources and services required to deliver information and technology to the business. This programme of work ensures the business has sufficient capacity, performance, and service levels to maintain the operation of technology systems whilst optimising data centre infrastructure to operate with more efficiency and resilience.

Consistent with Applications discussed above, Technology Asset Management Infrastructure upgrades are progressed based on risk criticality. Key activities completed across the last year include SCADA network re-designs, replacement of end-of-life SCADA and communications equipment, and deployment of network storage upgrades.

#### 15.1.4.3. Corporate Communications

Corporate communications at AusNet comprise technology networking devices (i.e., Wi-Fi, routers), internet services provision and gateways, as well as data centre interconnectivity, covering both systems and assets.

As is conducted for critical systems above, this programme expenditure on capacity management and like-for-like lifecycle refreshes ensures the network performance requirements are met for both existing and future business growth. Key activities in 2025 include upgrading end-of-life network switches as part of a multi-year network modernisation program and progressing the migration of legacy firewalls to enhance security.

### 15.1.5. Metering

This work stream aims to balance the risks and costs of maintaining AusNet metering systems, while meeting new regulatory compliance requirements.

#### 15.1.5.1. Metering Lifecycle

AusNet has technology systems that operate and coordinate metering functions with the rest of the distribution business.

In the current regulatory period, these systems will require periodic refreshes and patching to ensure they remain supported and well maintained. Maintaining ongoing vendor support and patch and bug fixes will limit downtime, which underpins the reliability of critical operations across the business.

Additionally, there is new market compliance rules that will require capability extensions of systems to ensure compliance. These refreshes will achieve both the compliance and lifecycle activities to achieve lowest possible costs. Compliant metering solutions underpin AusNet smart network capabilities, providing timely delivery of the necessary consumption, supply quality and exceedance data, which enables key functions in the monitoring of the electricity distribution network.

AusNet has commenced work to meet AEMO's new regulatory requirements for flexible trading, ahead of rule changes taking effect on 31 May and 1 November 2026. AusNet has continued to remain engaged with the AEMO Market Interface Technology Enhancements (MITE) program.

In addition, a large population of AusNet's AMI meter fleet age profile will exceed the forecast 15-year operational life advised by the meter manufacturer. Ongoing review of operational and lifecycle management and strategies to mitigate against larger scale meter population failure are proposed to be implemented during this forecast period. Meter replacements have been proposed in the EDPR submission, with bulk replacement planning underway for 2028.

## 15.2. Proposed expenditure in the upcoming regulatory period

Our plans for the 2026-31 regulatory period build on the strategic direction and momentum from the current regulatory period, in which AusNet had focused on cautiously modernising our business capabilities in an uncertain and complex environment.

From the strategic direction and momentum of the current regulatory period, in which AusNet had focused on cautiously modernising our business capabilities in an uncertain and complex environment, the upcoming 2026-31 period reflects a period of accelerated disruption. This period will see AusNet face complexities with adapting to the renewable energy transformation, managing extreme events from climate change and see increased cyber risks. In addition to these macro-drivers, our customers expect our network to be resilient, communications and interactions to be easy, and their uptake of consumer energy resources to be enabled.

In light of these drivers and customer preferences, we identified four strategic objectives for the 2026-31 period.

- Enhance our customer systems to save time for our customers, improve our communications, and enable us to provide more tailored services
- Modernise our network operations capability to prevent and improve response to events on our network, and manage the future of distributed energy assets
- Enhance our asset management systems, so we can manage our network efficiently to support reliability and resilience, mitigate risks, and optimise investment
- Maintain resilient, secure and compliant digital systems, to provide 24 / 7 operational capabilities and security against cyber threats

These objectives collectively align to an overarching vision to deliver digital capabilities that support network stability and growth while driving efficiency for our customers and our business. This vision and objectives are reflected in Figure 18, which aligns our ICT objectives with the Distribution business strategy.

Our vision	Deliver digital capabilities that support network stability & growth while driving efficiency for our customers and our business			
Our objectives	Enhance our customer systems to save time for our customers, improve our communications and enable us to provide more tailored services	Modernise our network operations capability to prevent and improve response to events on our network, and manage the future of distributed energy assets	Enhance our asset management systems, so we can manage our network efficiently to support reliability & resilience, mitigate risks, and optimise investment	Maintain resilient, secure and compliant digital systems, to provide 24 / 7 operational capabilities and security against cyber threats
Alignment to Distribution Strategy Themes				
1	Customer & Community	✓	✓	
2	Safe Network		✓	✓
3	Reliability & Resilience		✓	✓
4	Enabling Electrification		✓	
5	Digitalisation	✓	✓	✓
6	DSO		✓	
7	Integrating Customer Energy Resources	✓	✓	
8	Enabling Renewable Generation		✓	

**Figure 18: Vision to deliver digital capabilities that support network stability and growth**

AusNet submitted our proposal for the 2026-31 regulatory period in January 2025, which details our proposed programs and expenditure to deliver these objectives. Our revised proposal, addressing AER Draft Decision feedback, was lodged in December 2025.

# 16. Regional Development Plan

A regional development plan consisting of maps of AusNet network is provided on our corporate website, in accordance with the requirements of schedule 5.8 (n) of NER: <https://dapr.ausnetservices.com.au/>

These maps are updated annually and/or following major project completions to provide the latest available information on current and emerging feeder, zone substation and sub-transmission network limitations.

Any information provided using the system limitation template must be read in conjunction with the reporting DNSP's DAPR.

# 17. Advanced Metering Infrastructure Benefits

This section aims to highlight benefits of utilising advanced metering infrastructure (AMI) technology to support life support customers, guide network planning and industry response initiatives, and support network reliability initiatives.

## 17.1. Utilisation of AMI data for life support customers

In accordance with the requirements of clause 19.4.6(a) of the EDCoP, AusNet keeps vulnerable customers safe by utilising AMI technology installed across power network based on following:

Our last gasp system integrated within AMI analysis tool known as explore generate alerts to inform us when a Life Support Customer (LSC) becomes de-energised. When these alerts occur, a notification is delivered to the Customer Service Centre which triggers a process for a contact to be made with the person that resides at the NMI location.

Life support customers within and adjacent to upcoming planned outage areas have their recorded AMI voltage data reviewed, to ensure that those customers have been correctly referenced to the correct supply substation and have received the correct notification.

As a continuous improvement we have identified potential opportunity to make process more efficient.

## 17.2. Network planning and demand side response

In accordance with the requirements of clause 19.4.6(b) of the EDCoP AusNet utilises AMI data as explained below:

- (a) To determine historical and ten-year forward looking demand forecasts for our network which enables us to prepare for both maximum and minimum demands;
- (b) The AMI data information forms basis of driving optimum solution for network augmentation and replacement projects with an estimated delivery expenditure;
- (c) In accordance with the schedule 2 of the EDCoP, AusNet publishes voltage performance reporting;
- (d) The AMI Data is assessed to mitigate power quality issues raised by customers; and
- (e) Network planning assessment for evaluating load transfer capability at sub-transmission lines, zone substations and HV feeders.

## 17.3. Network Reliability Initiatives

In accordance with the requirements of clause 19.4.6(c) of the EDCoP, AusNet Services has:

- (f) developed the Explore tool, that provides alerts when voltage profiles are abnormal, which are reviewed daily, resulting in regular dispatch of fault response crews to site, often before partial faults escalate to become larger events or issues.
- (g) an Advanced Distribution Management System (ADMS) is under development which will ensure that near real time outage information, as provided by AMI, will be delivered to the Control Room, to ensure fault crews are dispatched at the earliest possible time.

## 17.4. Quality of Supply

Refer Section 12 and website (<https://dapr.ausnetservices.com.au/>)

# A. Glossary

Abbrev.	Name	Abbrev.	Name
<b>AFI</b>	Australian Forest Industries	<b>MDI</b>	Murrindindi Zone Substation
<b>APM</b>	Australian Paper Maryvale	<b>MFA</b>	Maffra Zone Substation
<b>BDL</b>	Bairnsdale Zone Substation	<b>MJG</b>	Merrijig Zone Substation
<b>BDSS</b>	Bairnsdale Switching Station	<b>MOE</b>	Moe Zone Substation
<b>BGE</b>	Belgrave Zone Substation	<b>MPS</b>	Morwell Power Station
<b>BHWF</b>	Bald Hills Wind Farm	<b>MSD</b>	Mansfield Zone Substation
<b>BM8</b>	Bombala feeders from NSW (BOM)	<b>MWE</b>	Morwell East Zone Substation
<b>BN</b>	Benalla Zone Substation	<b>MWN</b>	Morwell North Zone Substation
<b>BRA</b>	Boronia Zone Substation	<b>MWL</b>	Morwell Zone Substation
<b>BOM</b>	Bombala Zone Substation (Essential Energy)	<b>MWTS</b>	Morwell Terminal Station
<b>BRT</b>	Bright Zone Substation	<b>MWW</b>	Morwell West Substation
<b>BWA</b>	Barnawartha Zone Substation	<b>MYT</b>	Myrtleford Zone Substation
<b>BWN</b>	Berwick North Zone Substation	<b>NH</b>	North Heidelberg (Jemena)
<b>BWR</b>	Bayswater Zone Substation	<b>NLA</b>	Newmerella Zone Substation
<b>CBTS</b>	Cranbourne Terminal Station	<b>NRN</b>	Narre Warren Zone Substation
<b>CF</b>	Clover Flat Zone Substation	<b>OFR</b>	Officer Zone Substation
<b>CLN</b>	Clyde North Zone Substation	<b>PHI</b>	Phillip Island Zone Substation
<b>CLPS</b>	Clover Power Station	<b>PHM</b>	Pakenham Zone Substation
<b>CNR</b>	Cann River Zone Substation	<b>RUBA</b>	Rubicon 'A' Zone Substation
<b>CPK</b>	Chirnside Park Zone Substation	<b>RVE</b>	Rowville Zone Substation
<b>CRE</b>	Cranbourne Zone Substation	<b>RWN</b>	Ringwood North Zone Substation
<b>CYN</b>	Croydon Zone Substation	<b>RWT</b>	Ringwood Terminal Station 22 kV Yard
<b>DN</b>	Dandenong Zone Substation (UE)	<b>RWTS</b>	Ringwood Terminal Station
<b>DRN</b>	Doreen Zone Substation	<b>SFS</b>	Sassafras Zone Substation
<b>DSH</b>	Dandenong South Zone Substation	<b>SLE</b>	Sale Zone Substation
<b>DVY</b>	Dandenong Valley Zone Substation (UE)	<b>SLF</b>	Sugarloaf Reservoir Melbourne Water Substation
<b>ELM</b>	Eltham Zone Substation	<b>SMG</b>	South Morang Zone Substation
<b>EPG</b>	Epping Zone Substation	<b>SMR</b>	Seymour Zone Substation

<b>ERTS</b>	East Rowville Terminal Station	<b>SMTS</b>	South Morang Terminal Station
<b>FGY</b>	Ferntree Gully Zone Substation	<b>ST</b>	Somerton Zone Substation (Jemena)
<b>FTR</b>	Foster Zone Substation	<b>TGN</b>	Traralgon Zone Substation
<b>GNTS</b>	Glenrowan Terminal Station	<b>TRC</b>	Tumut River Council - NSW (Essential Energy)
<b>HPK</b>	Hampton Park Zone Substation	<b>TSTS</b>	Templestowe Terminal Station
<b>HPS</b>	Hume Power Station	<b>TT</b>	Thomastown Zone Substation
<b>KLK</b>	Kinglake Zone Substation	<b>TTS</b>	Thomastown Terminal Station
<b>KLO</b>	Kalkallo Zone Substation	<b>TWF</b>	Toora Wind Farm
<b>KMS</b>	Kilmore South Zone Substation	<b>UWY</b>	Upwey Zone Substation
<b>LDL</b>	Lilydale Zone Substation	<b>WGI</b>	Wonthaggi Zone Substation
<b>LFD</b>	ESSO Longford	<b>WGL</b>	Warragul Zone Substation
<b>LGA</b>	Leongatha Zone Substation	<b>WN</b>	Wangaratta Zone Substation
<b>LLG</b>	Lang Lang Zone Substation	<b>WO</b>	Wodonga Zone Substation
<b>LSSS</b>	Leongatha South Switching Station	<b>WOTS</b>	Wodonga Terminal Station
<b>LYD</b>	Lysterfield Zone Substation	<b>WT</b>	Watsonia Zone Substation
<b>LYS</b>	Loy Yang South Zone Substation	<b>WYK</b>	Woori Yallock Zone Substation
<b>MBTS</b>	Mt Beauty Terminal Station	<b>YEA</b>	Yea Substation
<b>MBY</b>	Mt Beauty Zone Substation	<b>YN</b>	Yallourn North Open Cut Zone Substation
<b>MDG</b>	Mt Dandenong Zone Substation	<b>YPS</b>	Yallourn Power Station

## B. Asset Management Strategy Reference

Document Scope	AMS Number	Description
High Level Summary	AMS 20-01	Electricity Distribution Network Asset management Strategy
High Level Summary	AMS 20-03	Network Contingency Plan
Process and System	AMS 20-12	Augmentation
Process and System	AMS 20-13	Enhanced Network Safety Strategy
Process and System	AMS 20-14	Infrastructure Security
Process and System	AMS 20-15	Quality of Supply
Process and System	AMS 20-16	Distribution Network Planning Standards and Guidelines
Process and System	AMS 20-23	Vegetation Management
Process and System	AMS 20-24	Sub-transmission line and Station Data for Planning Purposes
Process and System	AMS 20-30	Demand Forecasting Methodology
Process and System	AMS 20-35	Network Support Services
Process and System	AMS 20-50	Steady State Voltage Compliance
Plant Strategy	AMS 20-52	Conductor
Plant Strategy	AMS 20-53	Zone Substation Capacitor Banks
Plant Strategy	AMS 20-54	Circuit Breakers
Plant Strategy	AMS 20-55	Civil Infrastructure
Plant Strategy	AMS 20-56	Indoor Switchboards
Plant Strategy	AMS 20-57	Cross-arms
Plant Strategy	AMS 20-58	Distribution Transformers
Plant Strategy	AMS 20-59	Electrical Earths
Plant Strategy	AMS 20-60	MV Switches and ACRs
Plant Strategy	AMS 20-61	MV Fuse Switch Disconnectors
Plant Strategy	AMS 20-62	HV Switches, Disconnectors and Earth Switches
Plant Strategy	AMS 20-63	Instrument Transformers
Plant Strategy	AMS 20-64	Sub-Transmission Towers, Insulators and Ground Wires
Plant Strategy	AMS 20-65	Insulated Cable Systems
Plant Strategy	AMS 20-66	Insulators – High and Medium Voltage
Plant Strategy	AMS 20-67	Line Surge Arresters
Plant Strategy	AMS 20-68	Line Voltage Regulators
Plant Strategy	AMS 20-69	Pole-Top Capacitors
Plant Strategy	AMS 20-70	Poles
Plant Strategy	AMS 20-71	Power Transformers and Station Voltage Regulators
Plant Strategy	AMS 20-72	Protection and Control Systems
Plant Strategy	AMS 20-73	Public Lighting
Plant Strategy	AMS 20-76	Service Cables
Plant Strategy	AMS 20-77	Surge Diverters in Zone Substations
Plant Strategy	AMS 20-79	Neutral Earthing Devices
Plant Strategy	AMS 20-80	Auxiliary Power Supplies
Plant Strategy	AMS 20-81	Communication Systems
Plant Strategy	AMS 20-90	Zone Substation Transformer Contingency Plan

# C. Asset retirement and de-rating asset groupings

Assets have been categorised to align with the NER. Schedule 5.8 Clause (5) (b1) refers to individual asset reporting and Clause (5) (b2) refers to assets that can be reported together, referred to as Group Reporting in this Appendix.

**Table 31: AusNet proposed Asset Grouping**

Individual reporting	Group reporting
<p><b>Appendix A Zone substation transformers</b></p> <p><b>Appendix B Circuit breakers 66kV</b></p> <p><b>Appendix C Switchboards</b></p> <p><b>Appendix D Capacitor banks</b></p> <p><b>Appendix E Circuit breakers 22kV in zone substation</b></p>	<p><b>Appendix F Poles</b></p> <p><b>Appendix G Pole top structures</b></p> <p>G.1 Cross-arms</p> <p>G.2 Insulators</p> <p>G.3 Surge arrestors</p> <p>G.4 Pole top capacitors</p> <p>G.5 Other (dampers, armour rods, spreaders, brackets etc.)</p> <p><b>Appendix H Switchgear</b></p> <p>H.1 Automatic Circuit Reclosers</p> <p>H.2 Gas switches</p> <p>H.3 Isolators</p> <p>H.4 Other</p> <p><b>Appendix I Overhead conductor LV, HV and ST</b></p> <p><b>Appendix J Underground cables</b></p> <p><b>Appendix K Other underground assets</b></p> <p>K.1 Cable head terminations</p> <p>K.2 Pits</p> <p>K.3 LV Pillars</p> <p><b>Appendix L Distribution plant</b></p> <p>L.1 Circuit breakers – other</p> <p>L.2 Substation kiosk</p> <p>L.3 Distribution transformers</p> <p>L.4 Isolators</p> <p>L.5 Services</p> <p>L.6 Ring Main Unit</p> <p>L.7 Earthing cables</p> <p>L.8 Regulators</p> <p>L.9 Combo switches</p>

**Appendix M Protection and control room equipment and instrumentation**

- M.1 Protection relay
- M.2 Voltage Regulator Relay
- M.3 VAR (Capacitor Bank) controllers
- M.4 Batteries
- M.5 AC and DC distribution equipment
- M.6 Voltage/Current transformers

**Appendix N Communications and SCADA**

- N.1 Remote telemetry unit

**Appendix O Zone substation switchyard equipment**

- O.1 Surge arrestors
- O.2 Busses
- O.3 Terminations
- O.4 Steel structures

## D. Retired or de-rated grouped assets

Appendix B outlines the methodologies and assumptions used for grouped assets listed in Appendix D of this report and should be read in conjunction with Section 5, Network Asset Retirement and De-ratings.

The complete asset management strategies are available upon request to the contacts outlined in the Disclaimer at beginning of this report.

### D.1. Poles

The methodologies and assumptions for all sub-transmission and distribution pole replacements are described in Asset Management Strategy AMS 20-70.

This document outlines the methodologies that are combined to develop AusNet pole replacement strategy. Applying a condition-based replacement forecast over the next five years requires replacement or reinforcement of all very poor condition poles.

### D.2. Cross-arms

The methodologies and assumptions for all sub-transmission and distribution pole top cross-arm replacements are described in Asset Management Strategy AMS 20-57. This document outlines methodologies that are combined to develop AusNet cross arm replacement strategy.

End of life replacements are based on observed condition at time of inspection. The possible result of an inspection is that a crossarm may fail and made unserviceable, or it remains as serviceable.

Replacement volume can be forecasted based on historical failure data.

### D.3. Insulators

The methodologies and assumptions for all HV and MV insulators are described in Asset Management Strategy AMS 20-66. This document outlines methodologies and strategies such as new assets, inspection, maintenance and replacement that are combined to develop AusNet insulator replacement strategy. Insulators are also replaced when a pole or cross-arm is replaced.

### D.4. Surge Arrestors

The methodologies and assumptions for all line surge arrestor replacement are described in Asset Management Strategy AMS 20-67. This document outlines methodologies such as failure mode effect criticality analysis and risk assessment strategies that are combined to develop AusNet surge arrestor replacement strategy.

Surge arrester replacements are targeted in the highest bushfire risk areas as the REFCLs are being installed these areas.

### D.5. Pole Top Capacitors

The methodologies and assumptions for all pole top capacitor replacement are described in Asset Management Strategy AMS 20-69. This document outlines methodologies such as Inspection, Failure Mode, probability of failure assessments, consequence and risk treatment strategies that are combined to develop AusNet pole top capacitor replacement strategy.

## D.6. Conductors and associated Hardware

The methodologies and assumptions for all conductor and conductor hardware replacement are described in Asset Management Strategy AMS 20-52. This document outlines methodologies such as Failure Modes Effects Criticality Analysis and risk analysis strategies that are combined to develop AusNet conductor and conductor hardware replacement strategy.

## D.7. Gas Switches and Automatic Circuit Reclosers

The methodologies and assumptions for all Medium Voltage Switches and Automatic Circuit Reclosers (ACR) are described in Asset Management Strategy AMS 20-60. This document outlines methodologies such as Inspection, Failure Mode, probability of failure assessments, consequence and risk treatment strategies that are combined to develop AusNet Medium Voltage Switch and Automatic Circuit Recloser (ACR) replacement strategy.

## D.8. Isolators

The methodologies and assumptions for all Isolator replacements are described in Asset Management Strategy AMS 20-62. This document outlines methodologies such as Inspection, Failure Mode, probability of failure assessments, consequence and risk treatment strategies that are combined to develop AusNet Isolator replacement strategy.

Most replacements will occur in conjunction with station rebuilds or circuit breaker, instrument transformer, power transformer replacements.

## D.9. Underground Cables

The methodologies and assumptions for all Cable replacements are described in Asset Management Strategy AMS 20-65. This document lists the risk mitigation activities required to achieve this over time include replacement, refurbishment and maintenance activities which are developed based on current risk and extrapolated risk. The commission test program is now well established for all new cable circuits, excluding those in URD purely based on the volume of work presented in those estates. The commission test program provides, an opportunity to ensure that substandard circuits are not accepted and placed into service as well as providing a fingerprint of the circuit characteristics that can be used as a guide in determining circuit degradation during the service life of the cable circuit.

## D.10. Distribution Transformers

The methodologies and assumptions for all Distribution Transformer replacements are described in Asset Management Strategy AMS 20-58.

This document outlines methodologies such as Inspection, Failure Mode, probability of failure assessments, consequence and risk treatment strategies that are combined to develop AusNet distribution transformer replacement strategy. These methodologies and approaches utilise a combination of age-based replacement and condition-based replacement methods.

## D.11. Service Cables

The methodologies and assumptions for all service cable replacement are described in Asset Management Strategy AMS 20-76.

In order to manage the risk "as far as practicable" as per Electricity Safety Act, it is recommended to replace service cable that are approaching its end of service life."

## D.12. Protection and Control Room Equipment and Instrumentation

The methodologies and assumptions for all protection and control room equipment and instrumentation replacement are detailed in Asset Management Strategy AMS 20-72, AMS 20-80 and AMS 20-63. These documents outline methodologies such as Inspection, Failure Mode, probability of failure assessment, consequence and risk treatment strategies that are combined to develop AusNet protection and control room equipment and instrumentation replacement strategy.

Protection and control room equipment and instrumentation includes protection relays, voltage regulator relays, VAR (capacitor bank) controllers, batteries, AC and DC distribution equipment and voltage/current transformers.

## D.13. Communications and SCADA Remote Telemetry Units

The methodologies and assumptions for all remote telemetry unit (RTU) replacement are described in Asset Management Strategy AMS 20-72. This document outlines methodologies such as Service Age and Functionality Assessment strategies that are combined to develop AusNet RTU replacement strategy.

## D.14. Surge Arresters in Zone Substations

The methodologies and assumptions for all Surge Arresters in Zone Substations replacement are described in Asset Management Strategy AMS 20-77. This document outlines methodologies such as Inspection, Failure Mode, probability of failure assessments, consequence and risk treatment strategies that are combined to develop AusNet Surge Arresters in Zone Substations replacement strategy.

These methodologies and approaches have identified surge arresters that need to be replaced in conjunction with Zone Substation rebuild projects and those as standalone replacements.

## E. Demand forecasts

### E.1. Maximum demand forecasts for sub-transmission lines -Summer and Winter

Table 32: Maximum Demand Forecast for sub-transmission - Winter and Summer

Sub-T Loop	Sub-T Loop Name	Firm Capacity Winter (MVA)	24/25 PF - Winter	24/25 Max Winter Demand (MVA)	25/26	26/27	27/28	28/29	29/30	Firm Capacity Summer (MVA)	24/25 PF - Summer	24/25 Max Summer Demand (MVA)	25/26	26/27	27/28	28/29	29/30
<b>CBTS-LYD-NRN-PHM-OFR-BWN-LLG-CLNCBTS</b>	Cranbourne Terminal Station - Lysterfield - Narre Warren - Berwick North - Pakenham - Officer - Lang Lang - Clyde North	249	0.99	277.2	307.1	327.9	340.9	349.8	359.0	214	0.97	365.5	339.0	380.4	400.9	409.1	415.8
<b>RWTS-LDL-WYK-CPK-RWN</b>	Ringwood Terminal Station - Ringwood North - Chirnside Park - Lilydale - Woori Yallock	190	1.00	137.7	170.0	172.8	175.3	179.1	185.8	177	1.00	185.8	221.9	223.3	222.7	222.5	224.4

# AusNet

Sub-T Loop	Sub-T Loop Name	Firm Capacity Winter (MVA)	24/25 PF - Winter	24/25 Max Winter Demand (MVA)	25/26	26/27	27/28	28/29	29/30	Firm Capacity Summer (MVA)	24/25 PF - Summer	24/25 Max Summer Demand (MVA)	25/26	26/27	27/28	28/29	29/30
<b>ERTS-BGE-FGY-ERTS</b>	East Rowville Terminal Station - Ferntree Gully - Belgrave	109	1.00	73.1	84.7	85.3	86.1	86.6	89.1	102	0.99	74.1	90.0	90.8	90.2	90.1	90.1
<b>ERTS-DN-HPK-DSH-DVY-ERTS</b>	East Rowville Terminal Station - Hampton Park - Dandenong - Dandenong Valley - Dandenong South	379	0.99	232.2	303.2	304.5	306.4	309.6	311.6	352	0.98	300.4	330.1	332.0	333.8	334.9	335.0
<b>RWTS-BRA-BWR-CYN-RWTS</b>	Ringwood Terminal Station - Croydon - Bayswater - Boronia	291	1.00	171.2	200.8	205.7	210.7	217.0	230.4	260	0.99	185.4	235.5	237.2	238.3	239.0	241.9
<b>TSTS-SLF</b>	Templestowe Terminal Station - Sugarloaf	0	1.00	20.0	20.6	20.6	20.6	20.6	20.6	0	1.00	20.0	20.6	20.6	20.6	20.6	20.6
<b>TSTS-ELM</b>	Templestowe Terminal Station - Eltham	77	1.00	64.8	70.3	71.4	72.4	73.0	74.8	77	1.00	74.4	90.3	90.7	90.5	90.1	90.5

# AusNet

Sub-T Loop	Sub-T Loop Name	Firm Capacity Winter (MVA)	24/25 PF - Winter	24/25 Max Winter Demand (MVA)	25/26	26/27	27/28	28/29	29/30	Firm Capacity Summer (MVA)	24/25 PF - Summer	24/25 Max Summer Demand (MVA)	25/26	26/27	27/28	28/29	29/30
<b>SMTS-DRN-KLK-MDI-RUBA-YEA-SMR-KMS-KLO-SMTS</b>	South Morang Terminal Station - Doreen - Kinglake - Murrindindi - Rubicon - Yea - Seymour - Kilmore South - Kalkallo	254.1	0.98	186.3	210.2	224.8	255.6	280.8	299.2	230	0.97	210	221.1	239.3	251.1	281.6	304.3
<b>SMTS-EPG</b>	South Morang Terminal Station - Epping	126	1.00	72.7	100.8	106.5	105.9	109.3	115.6	117	1.00	83.4	115.6	125.6	128.8	127.1	129.2
<b>TTS-NEI-NH-WT-TTS</b>	Thomastown Terminal Station - Watsonia - North Heidelberg - Nilsen Electrical Industries	126	1.00	93.8	106.3	103.7	106.7	108.5	111.4	117	1.00	120.1	132.7	134.0	134.5	134.6	136.4
<b>TTS-TT</b>	Thomastown Terminal Station - Thomastown	91	0.99	68.3	80.4	81.9	85.7	89.4	97.1	88	1.00	75.2	84.6	85.3	85.2	85.6	87.2
<b>GNTS-BN</b>	Glenrowan Terminal Station - Benalla	112	0.99	62.9	83.6	86.4	88.8	90.5	97.9	105	0.99	51.2	75.4	75.7	75.6	76.2	75.8

# AusNet

Sub-T Loop	Sub-T Loop Name	Firm Capacity Winter (MVA)	24/25 PF - Winter	24/25 Max Winter Demand (MVA)	25/26	26/27	27/28	28/29	29/30	Firm Capacity Summer (MVA)	24/25 PF - Summer	24/25 Max Summer Demand (MVA)	25/26	26/27	27/28	28/29	29/30
<b>BN-MSD</b>	Benalla - Mansfield	0	0.99	30.4	39.1	40.4	41.9	42.6	47.1	0	1.00	17.7	25.1	25.2	25.3	25.2	25.3
<b>MSD-MJG</b>	Mansfield - Merrijig	0	0.97	14.2	18.0	18.8	19.7	19.6	22.7	0	0.99	1.9	3.8	3.9	4.0	3.9	4.0
<b>GNTS-WN</b>	Glenrowan Terminal Station - Wangaratta	83	1.00	69.7	89.5	91.9	93.3	95.8	104.3	83	0.99	71.2	93.6	94.4	94.1	94.9	94.7
<b>WN-MYT-BRT-MBTS</b>	Mount Beauty Terminal Station - Bright - Myrtleford - Wangaratta	49	1.00	29.3	38.2	39.5	40.6	42.1	45.2	33	1.00	23.3	29.4	29.5	29.5	29.5	29.7
<b>MBTS-MBY</b>	Mount Beauty Terminal Station - Mount Beauty	0	0.99	8.2	9.7	9.9	10.1	10.4	10.9	0	0.83	4.0	5.3	5.4	5.4	5.4	5.5
<b>WOTS-HPS</b>	Wodonga Terminal Station - Hume Power Station	0	1.00	50.0	51.5	51.5	51.5	51.5	51.5	0	1.00	50.0	51.5	51.5	51.5	51.5	51.5

# AusNet

Sub-T Loop	Sub-T Loop Name	Firm Capacity Winter (MVA)	24/25 PF - Winter	24/25 Max Winter Demand (MVA)	25/26	26/27	27/28	28/29	29/30	Firm Capacity Summer (MVA)	24/25 PF - Summer	24/25 Max Summer Demand (MVA)	25/26	26/27	27/28	28/29	29/30
<b>WOTS-WO</b>	Wodonga Terminal Station - Wodonga	87	1.00	50.9	61.8	62.6	64.0	65.4	67.8	65	0.98	54.8	69.7	69.9	70.0	70.3	70.9
<b>WO-BWA</b>	Wodonga - Barnawartha	0	0.99	10.1	14.5	14.6	14.9	15.1	16.0	0	0.97	11.7	16.5	16.5	16.4	16.4	16.4
<b>MBTS-CLPS-CF</b>	Mount Beauty Terminal Station - Clover Flat - Clover Power Station	0	1.00	29.0	29.9	29.9	29.9	29.9	29.9	0	0.92	29.0	29.9	29.9	29.9	29.9	29.9
<b>MWTS-YPS-MOE-WGL-MWTS</b>	Morwell Terminal Station - Yallourn - Moe - Warragul	130	1.00	92.6	118.5	125.4	131.1	132.7	138.9	114	1.00	105.6	134.5	138.8	143.3	149.5	149.9
<b>MWTS-TGN-SLE-MFA-BDSS-BDL</b>	Morwell Terminal Station Traralgon - Sale - Maffra - Bairnsdale - Bairnsdale Switching Station	107	0.98	154.1	174.6	182.5	188.7	194.3	201.1	86.3	0.99	163.8	182.5	191.3	196.8	200.8	201.4

# AusNet

Sub-T Loop	Sub-T Loop Name	Firm Capacity Winter (MVA)	24/25 PF - Winter	24/25 Max Winter Demand (MVA)	25/26	26/27	27/28	28/29	29/30	Firm Capacity Summer (MVA)	24/25 PF - Summer	24/25 Max Summer Demand (MVA)	25/26	26/27	27/28	28/29	29/30
<b>BDL-NLA</b>	Bairnsdale-Newmerella	0	1.00	9.5	12.4	12.7	12.9	13.2	14.0	0	0.99	9.5	11.4	11.7	11.7	11.7	11.8
<b>NLA-CNR</b>	Newmerella-Cann River	0	1.00	2.2	2.6	2.7	2.7	2.8	3.0	0	1.00	2.5	2.7	2.8	2.7	2.7	2.7
<b>LGA-WGI</b>	Leongatha - Wonthaggi	43	1.00	55.7	78.4	80.2	80.2	81.0	82.8	32	0.98	60.0	90.3	91.0	90.9	90.8	91.2
<b>WGI-PHI</b>	Wonthaggi - Phillip Island	0	0.99	20.3	24.8	25.0	25.1	25.5	26.0	0	0.96	21.3	29.0	29.5	29.5	29.4	29.6

## E.2. Minimum demand forecasts for sub-transmission lines

Table 33: Minimum demand forecasts for sub-transmission lines

Sub-T Loop	Subtransmission Lines	N' Export Rating (MVA)	2025 Minimum Demand		Minimum Demand (MVA)				
			Power Factor	MW	2026	2027	2028	2029	2030
<b>BDL-NLA</b>	Bairnsdale - Newmerella	19.43	0.68	-1.80	-4.12	-4.55	-4.87	-4.98	-5.31
<b>BDSS-BDL1</b>	Bairnsdale Switching Station - Bairnsdale	101.74	0.85	-5.88	-12.28	-13.36	-14.06	-14.57	-15.03
<b>BDSS-BDL2</b>	Bairnsdale Switching Station - Bairnsdale	101.74	0.83	-3.93	-9.67	-10.52	-11.07	-11.46	-11.83
<b>BDSS-MFA1</b>	Bairnsdale Switching Station - Maffra	39.44	0.96	-15.60	-6.4	-6.91	-7.23	-7.46	-7.67
<b>BDSS-MFA2</b>	Bairnsdale Switching Station - Maffra	34.29	0.85	-16.14	-6.86	-7.41	-7.75	-8.01	-8.24
<b>BDSS-SLE</b>	Bairnsdale Switching Station - Sale	91.45	0.95	-26.42	-8.04	-8.83	-9.35	-9.71	-10.06
<b>NLA-CNR</b>	Newmerella - Cann River	48.36	1	-0.05	-1.73	-1.79	-1.86	-1.86	-1.93
<b>BGE-FGY</b>	Belgrave - Ferntree Gully	74.30	1	-18.70	-1.33	-1.38	-1.37	-1.43	-1.44
<b>BN-MSD</b>	Benalla - Mansfield	65.16	1	-10.80	-8.52	-9.23	-9.74	-10.14	-10.57
<b>BRA-BWR</b>	Boronia - Bayswater	80.02	1	0.50	0.69	1.06	1.22	1.41	1.45
<b>BWN-OFR</b>	Berwick North - Officer	77.73	0.93	-18.54	-18.73	-20.41	-21.76	-22.8	-23.57
<b>CBTS-CLN1</b>	Cranbourne Terminal Station - Clyde North	117.17	0.93	-39.68	-46.84	-51.72	-55.69	-58.76	-61.31
<b>CBTS-CLN2</b>	Cranbourne Terminal Station - Clyde North	117.17	0.93	-41.60	-46.84	-51.72	-55.69	-58.76	-61.31
<b>CBTS-CRE2</b>	Cranbourne Terminal Station - Cranbourne	67.45	0.98	-9.30	-7.02	-7.02	-7.02	-7.02	-7.02
<b>CBTS-CRE3</b>	Cranbourne Terminal Station - Cranbourne	67.45	0.98	-9.30	-7.02	-7.02	-7.02	-7.02	-7.02
<b>CLN_PHM-LLG</b>	Clyde North - Pakenham - Lang Lang	117.17	0.93	-8.50	-15.27	-16.77	-17.8	-18.54	-19.11
<b>CLPS-CF</b>	Clover Power Station - Clover Flat	19.80	0.1	-0.29	-0.82	-0.82	-0.82	-0.82	-0.82
<b>CPK-LDL</b>	Chirnside Park - Lilydale	101.74	0.96	-3.80	-6.28	-7.29	-7.97	-8.45	-8.83

Sub-T Loop	Subtransmission Lines	N' Export Rating (MVA)	2025 Minimum Demand		Minimum Demand (MVA)				
			Power Factor	MW	2026	2027	2028	2029	2030
<b>DRN-KLK</b>	Doreen - Kinglake	43.44	0.71	-21.60	-31.66	-32.35	-32.83	-33.35	-33.55
<b>ERTS-BGE</b>	East Rowville Terminal Station - Belgrave	101.74	0.95	-4.01	-10.16	-10.84	-11.37	-11.71	-12
<b>ERTS-DN</b>	East Rowville Terminal Station - Dandenong	117.17	1	-4.15	-11.26	-20.94	-21.53	-22.15	-14.22
<b>ERTS-DSH</b>	East Rowville Terminal Station - Dandenong South	117.17	0.05	-0.90	-8.07	-8.78	-9.71	-8.93	-9.79
<b>ERTS-DVY</b>	East Rowville Terminal Station - Dandenong Valley	117.17	0.05	-0.90	-7.77	-5.89	3.63	9.46	9.06
<b>ERTS-FGY</b>	East Rowville Terminal Station - Ferntree Gully	101.74	0.95	-5.40	-13.75	-14.69	-15.48	-15.94	-16.35
<b>ERTS-HPK</b>	East Rowville Terminal Station - Hampton Park	117.17	1	-22.90	-15.76	-18.9	-19.58	-20.18	-18.49
<b>ERTS-HPK_DN</b>	East Rowville Terminal Station - Hampton Park - Dandenong	117.17	1	-10.80	-15.76	-18.9	-19.58	-20.18	-18.49
<b>GNTS-BN1</b>	Glenrowan Terminal Station - Benalla	104.60	0.97	-3.30	-9.13	-9.85	-10.37	-10.8	-11.19
<b>GNTS-BN2</b>	Glenrowan Terminal Station - Benalla	104.60	0.97	-5.50	-9.27	-10	-10.54	-10.97	-11.37
<b>GNTS-WN1</b>	Glenrowan Terminal Station - Wangaratta	101.74	1	-4.30	-4.13	-5.01	-5.73	-6.29	-6.65
<b>GNTS-WN2</b>	Glenrowan Terminal Station - Wangaratta	102.88	1	-7.70	-4.21	-5.11	-5.84	-6.41	-6.78
<b>HPK-DN</b>	East Rowville Terminal Station - Dandenong	117.17	1	-10.60	18.48	14.01	14.67	15.15	20.44
<b>KLO-DRN</b>	Kalkallo - Doreen	117.17	1	-27.10	25.32	28.51	31.6	34.37	36.88
<b>LDL-WYK1</b>	Lilydale - Woori Yallock	65.16	0.96	-2.29	-4.06	-4.54	-4.86	-5.13	-5.34
<b>LDL-WYK2</b>	Lilydale - Woori Yallock	65.16	0.96	-2.16	-5.6	-6.07	-6.38	-6.64	-6.85
<b>LGA/WGI-LSSS1</b>	Leongatha - Wonthaggi - Leongatha Switching Station	101.74	0.99	16.00	9.97	9.96	9.8	9.76	9.71
<b>LGA_WGI-LSSS2</b>	Leongatha - Wonthaggi - Leongatha Switching Station	101.74	0.99	18.30	18.02	18.01	17.81	17.87	17.8
<b>LSSS-BHWF 1</b>	Leongatha Switching Station - Bald Hills Wind Farm	100.70	0.97	-57.50	-60.26	-60.25	-60.11	-60.19	-60.13
<b>LSSS-BHWF 2</b>	Leongatha Switching Station - Bald Hills Wind Farm	100.70	0.98	-45.50	-60.55	-60.55	-60.37	-60.57	-60.49
<b>LYD-NRN</b>	Lysterfield - Narre Warren	77.73	0.93	-10.97	-13.35	-14.8	-15.89	-16.67	-17.3
<b>MBTS-BRT</b>	Mount Beauty Terminal Station - Bright	39.44	0.87	-12.60	-16.1	-16.66	-17.03	-17.44	-17.59
<b>MBTS-MBY</b>	Mount Beauty Terminal Station - Mount Beauty	41.15	0.87	-1.42	-5.33	-5.52	-5.9	-5.9	-6.09
<b>MDI-RUBA_KLK</b>	Murrindindi - Rubicon - Kinglake	41.15	0.71	-19.65	-31.22	-31.83	-32.26	-32.68	-32.89

Sub-T Loop	Subtransmission Lines	N' Export Rating (MVA)	2025 Minimum Demand		Minimum Demand (MVA)				
			Power Factor	MW	2026	2027	2028	2029	2030
<b>MFA-SLE</b>	Maffra - Sale	49.73	0.95	-7.96	-9.35	-9.95	-10.32	-10.58	-10.71
<b>MSD-MJG</b>	Mansfield - Merrijig	64.02	0.97	-2.45	-0.68	-0.69	-0.69	-0.69	-0.75
<b>MWTS-APM1</b>	Morwell Terminal Station - Australian Paper Mill	100.71	0.89	1.24	16.04	16.04	16.04	16.04	16.05
<b>MWTS-APM2</b>	Morwell Terminal Station - Australian Paper Mill	100.71	0.83	0.84	15.31	15.31	15.31	15.31	15.31
<b>MWTS-FTR_TWF</b>	Morwell Terminal Station - Foster - Toora Wind Farm	62.87	0.92	-18.70	-20.17	-20.14	-20.1	-20.11	-20.11
<b>MWTS-LGA_FTR</b>	Morwell Terminal Station - Leongatha - Foster	102.88	0.92	-39.20	-40.33	-40.25	-40.18	-40.78	-40.78
<b>MWTS-LGA2</b>	Morwell Terminal Station - Leongatha	39.44	0.92	-35.10	-39.58	-39.55	-39.52	-39.74	-39.76
<b>MWTS-LGA3</b>	Morwell Terminal Station - Leongatha	64.59	0.92	-44.90	-42.87	-42.73	-42.65	-43.26	-43.26
<b>MWTS-MFA</b>	Morwell Terminal Station - Maffra	73.73	0.95	-14.90	-13.22	-14.32	-15.06	-15.58	-15.93
<b>MWTS-MOE</b>	Morwell Terminal Station - Moe	49.73	0.89	-4.56	-7.41	-7.91	-8.29	-8.55	-8.7
<b>MWTS-SLE</b>	Morwell Terminal Station - Sale	90.31	0.95	-17.50	-13.89	-15.02	-15.74	-16.26	-16.66
<b>MWTS-TGN1</b>	Morwell Terminal Station -Traralgon	39.44	0.95	-6.37	-11.71	-12.76	-13.53	-14.13	-14.53
<b>MWTS-TGN2</b>	Morwell Terminal Station -Traralgon	91.45	0.95	-8.40	-9.71	-10.89	-11.72	-12.39	-12.83
<b>MWTS-YPS1</b>	Morwell Terminal Station - Yallourn	64.02	0.89	-4.90	-11	-11.63	-12.14	-12.49	-12.73
<b>MWTS-YPS2</b>	Morwell Terminal Station - Yallourn	100.60	0.89	-3.47	-15.38	-16.55	-17.41	-18.01	-18.39
<b>MYT - AFI</b>	Myrtleford - Australian Forestry Industry	39.44	0	0.00	2.19	2.19	2.19	2.19	2.19
<b>MYT-BRT</b>	Myrtleford - Bright	35.44	0.87	-12.05	15.74	16.17	16.47	16.77	16.93
<b>NRN-PHM</b>	Narre Warren - Pakenham	77.73	0.93	-23.90	-11.24	-12.39	-13.28	-13.97	-14.51
<b>RUBA-YEA</b>	Rubicon - Yea	64.02	0.92	-20.10	-25.41	-25.72	-25.95	-26.17	-26.29
<b>RWTS-BRA</b>	Ringwood Terminal Station - Boronia	117.17	0.91	-1.90	-7.57	-8.64	-9.31	-9.84	-10.1
<b>RWTS-BWR</b>	Ringwood Terminal Station - Bayswater	117.17	0.91	-2.50	-7.17	-7.97	-8.53	-8.92	-9.16
<b>RWTS-CPK</b>	Ringwood Terminal Station - Chirnside Park	101.74	0.96	-4.76	-9.85	-11.13	-12.01	-12.7	-13.16
<b>RWTS-CYN</b>	Ringwood Terminal Station - Croydon	101.74	0.91	-3.10	-7.4	-8.19	-8.78	-9.2	-9.49
<b>RWTS-CYN_BWR</b>	Ringwood Terminal Station - Croydon - Bayswater	117.17	0.91	-2.80	-8.73	-9.71	-10.42	-10.91	-11.23

Sub-T Loop	Subtransmission Lines	N' Export Rating (MVA)	2025 Minimum Demand		Minimum Demand (MVA)				
			Power Factor	MW	2026	2027	2028	2029	2030
<b>RWTS-LDL</b>	Ringwood Terminal Station - Lilydale	101.74	0.96	0.10	-8.78	-9.98	-10.79	-11.41	-11.84
<b>RWTS-RWN</b>	Ringwood Terminal Station - Ringwood North	117.17	0.96	-2.70	-5.15	-5.68	-6.12	-6.41	-6.65
<b>RWTS-RWN_CPK</b>	Ringwood Terminal Station - Ringwood North - Chirnside Park	117.17	0.96	-5.31	-11.51	-12.94	-13.98	-14.75	-15.3
<b>SLE-LFD</b>	Sale - Longford	64.02	0.95	-4.50	-6.02	-6.02	-6.02	-6.02	-6.02
<b>SMR-KMS</b>	Seymour - Killmore South	49.73	0.5	38.00	37.8	38.23	38.51	38.81	38.88
<b>SMR-YEA-CTWF</b>	Seymour - Yea - Cherry Tree Wind Farm	64.02	0.94	-21.40	-32.52	-32.38	-32.26	-32.15	-32.06
<b>SMTS-DRN1</b>	South Morang Terminal Station - Doreen	117.17	0.71	-29.20	-11.63	-13.41	-14.82	-15.8	-16.35
<b>SMTS-DRN2</b>	South Morang Terminal Station - Doreen	117.17	0.71	-29.20	-7.36	-8.49	-9.38	-10	-10.35
<b>SMTS-EPG1</b>	South Morang Terminal Station - Epping	117.17	0	-14.20	-11.63	-13.41	-14.82	-15.8	-16.35
<b>SMTS-EPG2</b>	South Morang Terminal Station - Epping	117.17	0	-4.80	-7.36	-8.49	-9.38	-10	-10.35
<b>SMTS-KLO-KMS</b>	South Morang Terminal Station - Kalkallo - Killmore South	117.17	0.71	-28.10	-48.85	-52.91	-56.62	-59.95	-62.83
<b>SMTS-KMS</b>	South Morang Terminal Station - Killmore South	33.72	0.71	-11.48	-18.04	-18.8	-19.42	-19.98	-20.39
<b>SMTS-SMG2</b>	South Morang Terminal Station - South Morang	56.60	0.9	-0.17	-3.62	-4.24	-4.62	-4.92	-5.15
<b>SMTS-SMG3</b>	South Morang Terminal Station - South Morang	56.60	0.9	0.00	-3.59	-4.2	-4.58	-4.89	-5.11
<b>TGN-MFA</b>	Taralgon_Maffra	39.44	0.95	-11.82	-9.66	-10.45	-10.97	-11.31	-11.55
<b>TSTS-ELM1</b>	Templestowe Terminal Station - Eltham	77.16	1	-4.89	-10.45	-11.707	-12.699	-13.427	-13.89
<b>TSTS-ELM2</b>	Templestowe Terminal Station - Eltham	77.16	1	-3.50	-7.483	-8.3829	-9.0933	-9.6142	-9.9458
<b>TTS-TT1</b>	Thomastown Terminal Station - Thomastown	88.02	0.2	0.10	-3.85	-4.1	-4.2	-4.2	-4.2
<b>TTS-TT2</b>	Thomastown Terminal Station - Thomastown	88.02	0.2	0.10	-3.85	-4.1	-4.2	-4.2	-4.2
<b>TTS-WT</b>	Thomastown Terminal Station - Watsonia	117.17	0.97	0.30	-1.0829	-1.3212	-1.4945	-1.6244	-1.6894
<b>WGI-PHI</b>	Wonthaggi - Phillip Island	41.15	0.92	-7.13	-5.23	-5.26	-5.16	-5.15	-5.13
<b>WN-MYT</b>	Wangaratta - Myrtleford	33.15	0.77	-7.51	-9.12	-8.97	-8.93	-8.78	-8.82
<b>WO-BWA</b>	Wodonga - Barnawartha	64.02	0.48	-5.22	-7.56	-7.56	-7.76	-7.76	-7.86
<b>WOTS-WO1</b>	Wodonga Terminal Station - Wodonga	74.30	0.48	-5.30	-4.64	-5.05	-5.47	-5.66	-5.84

# AusNet

Sub-T Loop	Subtransmission Lines	N' Export Rating (MVA)	2025 Minimum Demand		Minimum Demand (MVA)				
			Power Factor	MW	2026	2027	2028	2029	2030
<b>WOTS-WO2</b>	Wodonga Terminal Station - Wodonga	65.16	0.48	-5.80	-5.27	-5.74	-6.22	-6.43	-6.64
<b>YPS-WGL_MOE1</b>	Yallourn - Warragul - Moe	52.58	1	-13.57	-13.41	-14.08	-14.62	-14.99	-15.22
<b>YPS-WGL_MOE2</b>	Yallourn - Warragul - Moe	52.58	1	-20.07	-15.41	-16.59	-17.46	-18.07	-18.45

\* Negative value indicates that the power flow is towards source.

### E.3. Capacity of sub-transmission network

Table 34: Available capacity of sub-transmission network

Sub-T Loop	Sub-T Loop Name	Terminal Station	Embedded Generation Capacity (MVA)	Installed capacity (MVA)	Firm Capacity Winter (MVA)	Load Transfer Capacity (MVA)	Estimated Hours at 95% of Peak Load (Winter)	Firm Capacity Summer (MVA)	Load Transfer Capacity (MVA)	Estimated Hours at 95% of Peak Load (Summer)
<b>CBTS-LYD-NRN-PHM-OFR-BWN-LLG-CLNCBTS</b>	Cranbourne Terminal Station - Lysterfield - Narre Warren - Berwick North - Pakenham - Officer - Lang Lang - Clyde North	CBTS	0.2	320	229	35	5.88	214	35	15.9
<b>RWTS-LDL-WYK-CPK-RWN</b>	Ringwood Terminal Station - Ringwood North - Chirnside Park - Lilydale - Woori Yallock	RWTS	4.5	438	177	30.2	16.16	190	30.2	1.8
<b>ERTS-BGE-FGY-ERTS</b>	East Rowville Terminal Station - Ferntree Gully - Belgrave	ERTS	3.8	203	102	7.8	3.86	109	7.8	0.7
<b>ERTS-DN-HPK-DSHDVY-ERTS</b>	East Rowville Terminal Station - Hampton Park - Dandenong - Dandenong Valley - Dandenong South	ERTS	8.8	469	352	12.4	5.88	379	12.4	3.6
<b>RWTS-BRA-BWR-CYNRWTS</b>	Ringwood Terminal Station - Croydon - Bayswater - Boronia	RWTS	2	453	260	40.7	8.26	291	40.7	1.1
<b>TSTS-SLF</b>	Templestowe Terminal Station - Sugarloaf	TSTS	4	54	0	0.0	0.00	0	0.0	0.0
<b>TSTS-ELM</b>	Templestowe Terminal Station - Eltham	TSTS	0	154	77	20.9	5.14	77	20.9	3.3

# AusNet

Sub-T Loop	Sub-T Loop Name	Terminal Station	Embedded Generation Capacity (MVA)	Installed capacity (MVA)	Firm Capacity Winter (MVA)	Load Transfer Capacity (MVA)	Estimated Hours at 95% of Peak Load (Winter)	Firm Capacity Summer (MVA)	Load Transfer Capacity (MVA)	Estimated Hours at 95% of Peak Load (Summer)
<b>SMTS-DRN-KLK-MDI-RUBA-YEA-SMR-KMSKLO-SMTS</b>	South Morang Terminal Station - Doreen - Kinglake - Murrindindi - Rubicon - Yea - Seymour - Killmore South - Kalkallo	SMTS	83.66	385	268	25.7	2.57	300	25.7	0.7
<b>DRN-KLK-MDI-RUBAYEA-SMR-KMS</b>	Doreen - Kinglake - Murrindindi - Rubicon - Yea - Seymour - Killmore South	SMTS	8.8	93	35	1.4	5.14	35	1.4	1.1
<b>SMTS-EPG</b>	South Morang Terminal Station - Epping	SMTS	2	234	117	12.2	17.26	126	12.2	1.1
<b>TTS-NEI-NH-WT-TTS</b>	Thomastown Terminal Station - Watsonia - North Heidelberg - Nilsen Electrical Industries	TTS	0	234	117	16.5	1.84	126	16.5	1.1
<b>TTS-TT</b>	Thomastown Terminal Station - Thomastown	TTS	0	176	88	11.2	5.14	91	11.2	1.4
<b>GNTS-BN</b>	Glenrowan Terminal Station - Benalla	GNTS	0.15	209	105	0.0	3.67	112	0.0	3.3
<b>BN-MSD</b>	Benalla - Mansfield	GNTS	0	65	0	0.5	6.24	0	0.5	3.6
<b>MSD-MJG</b>	Mansfield - Merrijig	GNTS	0	64	0	0.5	0.37	0	0.5	0.7
<b>GNTS-WN</b>	Glenrowan Terminal Station - Wangaratta	GNTS	241	205	83	4.3	1.47	83	4.3	2.2
<b>WN-MYT-BRT-MBTS</b>	Mount Beauty Terminal Station - Bright - Myrtleford - Wangaratta	MBTS	22	73	33	1.6	5.88	49	1.6	0.7
<b>MBTS-MBY</b>	Mount Beauty Terminal Station - Mount Beauty	MBTS	0	41	0	0.0	1.10	0	0.0	3.3

# AusNet

Sub-T Loop	Sub-T Loop Name	Terminal Station	Embedded Generation Capacity (MVA)	Installed capacity (MVA)	Firm Capacity Winter (MVA)	Load Transfer Capacity (MVA)	Estimated Hours at 95% of Peak Load (Winter)	Firm Capacity Summer (MVA)	Load Transfer Capacity (MVA)	Estimated Hours at 95% of Peak Load (Summer)
<b>WOTS-HPS</b>	Wodonga Terminal Station - Hume Power Station	WOTS	50	65	0	0.0	0.00	0	0.0	0.0
<b>WOTS-WO</b>	Wodonga Terminal Station - Wodonga	WOTS	2	139	65	0.0	1.84	87	0.0	0.7
<b>WO-BWA</b>	Wodonga - Barnawartha	WOTS	5	64	0	5.4	0.00	0	5.4	0.0
<b>MBTS-CLPS-CF</b>	Mount Beauty Terminal Station - Clover Flat - Clover Power Station	MBTS	29	20	0	0.0	0.00	0	0.0	0.0
<b>MWTS-YPS-MOEWGL-MWTS</b>	Morwell Terminal Station - Yallourn - Moe - Warragul	MWTS	15.7	214	114	4.3	0.55	130	4.3	0.2
<b>MWTS-TGN-SLE-MFABDSS-BDL</b>	Morwell Terminal Station - Traralgon - Sale - Maffra - Bairnsdale - Bairnsdale Switching Station	MWTS	109.3	295	120	8.6	7.71	120	8.6	2.9
<b>BDL-NLA</b>	Bairnsdale - Newmerella	MWTS	0	19	0	2.0	6.24	0	2.0	1.8
<b>NLA-CNR</b>	Newmerella - Cann River	MWTS	2	48	0	3.0	5.14	0	3.0	0.4
<b>MWTS-LGA-FTR-MWTS</b>	Morwell Terminal Station - Leongatha - Foster	MWTS	21	245	92	3.0	4.04	131	3.0	1.8
<b>LGA-WGI</b>	Leongatha - Wonthaggi	MWTS	118.6	82	32	3.0	2.02	43	3.0	0.9
<b>WGI-PHI</b>	Wonthaggi - Phillip Island	MWTS	5	41	0	6.8	1.84	0	6.8	0.4

## E.4. Maximum demand forecasts for zone substations

Table 35: Maximum demand forecasts for zone substations – Winter and Summer

ZSS	Name	Name Plate Rating (MVA)	Winter								Summer							
			Firm Capacity Winter (MVA)	Historical		Forecast 10% POE (MVA)					Firm Capacity Summer (MVA)	Historical		Forecast 10% POE (MVA)				
				2025 PF	2025 Load (MVA)	2026	2027	2028	2029	2030		24/25 PF	24/25 Load (MVA)	25/26	26/27	27/28	28/29	29/30
BDL	Bairnsdale	81	71.2	0.98	53.8	61.7	62.7	66.5	69.2	74.1	65.8	0.98	54.5	62.3	62.7	63.7	64.1	64.8
BGE	Belgrave	66	47.3	1.00	28	34	34.1	34.2	34.2	34.9	40.4	0.97	31.2	35.4	36.3	36	35.9	35.9
BN	Benalla	40.5	36.8	0.99	32.5	38.8	40	40.8	41.7	44.1	30.7	0.99	33.5	44.6	44.8	44.6	45.3	44.8
BRA	Boronia	99	86.1	1.00	55.1	61.9	62.4	62.9	63.5	65.6	77.8	0.99	68.7	78.3	78.6	78.9	78.4	78.9
BRT	Bright	40	30	1	14.4	17.5	18.1	18.6	19.3	20.6	27.9	0.99	9.3	11.3	11.3	11.4	11.3	11.4
BWA	Barnawartha	33	0	0.99	10.1	13.8	13.9	14.2	14.4	15.2	0	0.97	11.7	15.7	15.7	15.6	15.6	15.6
BWN	Berwick North	33	0	1.00	32.8	31.5	31.9	32.1	32.5	33.1	0	1.00	32.9	37.3	37.3	37.3	37.5	37.7
BWR	Bayswater	81	78.6	1.00	56	59.5	62.2	64.8	68.1	74.8	66.2	0.98	52.3	62	62.8	63.4	64.3	65.7
CF	Clover Flat	10	7.3	1.00	7	9.4	9.8	9.8	10.5	11.3	6.7	0.92	1.5	1.8	1.8	1.8	1.9	2

# AusNet

			Winter								Summer							
				Historical		Forecast 10% POE (MVA)						Historical		Forecast 10% POE (MVA)				
ZSS	Name	Name Plate Rating (MVA)	Firm Capacity Winter (MVA)	2025 PF	2025 Load (MVA)	2026	2027	2028	2029	2030	Firm Capacity Summer (MVA)	24/25 PF	24/25 Load (MVA)	25/26	26/27	27/28	28/29	29/30
CLN	Clyde North	99	97.8	0.99	76.7	93.3	98.1	102.5	107.3	112.3	89.2	1.00	96.6	119.7	124.3	128	131.4	136.8
CNR	Cann River	10	0	1.00	2.2	2.5	2.6	2.6	2.7	2.9	0	1.00	2.5	2.6	2.7	2.6	2.6	2.6
CPK	Chirnside Park	66	48.6	1.00	32.4	37.9	38.5	38.8	39.4	40.1	48.8	0.99	47.5	52.8	53.2	53.3	53.2	53.8
CRE	Cranbourne	66	46.3	1.00	52	69.4	69.2	74.3	74.6	76.3	41.1	1.00	62.2	83.3	84.2	83.3	88.5	88.3
CYN	Croydon	99	94	1.00	60.1	68	69.5	71.1	73.1	77	83	1.00	64.4	81.9	82.4	82.5	82.8	83.6
DRN	Doreen	66	49.1	1.00	56.1	56.3	57.2	58.1	59	60.6	45.9	1.00	72.9	74.1	74.9	75	75.3	75.9
ELM	Eltham	99	89.1	1.00	64.8	66.3	67.4	68.3	68.9	70.6	80.7	1.00	74.4	85.2	85.6	85.4	85	85.4
EPG	Epping	99	98.1	1.00	72.7	95.1	100.5	99.9	103.1	109.1	87.8	1.00	83.4	109.1	118.5	121.5	119.9	121.9
FGY	Ferntree Gully	93	67.4	1.00	45.1	45.9	46.4	47	47.5	49.2	61.8	1.00	42.9	49.5	49.4	49.1	49.1	49.1
FTR	Foster	66	49	1.00	15	19.8	21.1	21.5	22	23.3	49.1	1.00	18	20.2	20.1	21.2	21.4	21.9
HPK	Hampton Park	99	90.7	1.00	51.2	53.1	53.1	53.2	53.2	53.8	81.6	1.00	63.2	73	74.6	74.1	73.7	73.6
KLK	Kinglake	10	7.4	1.00	6	7.3	7.5	7.9	8.1	8.6	7.4	0.94	6.4	6.6	6.7	6.6	6.7	6.7
KLO	Kalkallo	66	49.1	0.99	63.8	92.4	103	120.4	129.7	142.6	49.1	0.99	69.3	83.7	94.2	102.4	118.3	126.3
KMS	Kilmore Sth	30	14.5	1.00	15.4	17.8	18.4	18.7	19.3	19.9	16.6	0.98	16.1	19.8	20.4	20.7	21.2	21.4

# AusNet

ZSS	Name	Name Plate Rating (MVA)	Winter								Summer							
			Firm Capacity Winter (MVA)	Historical		Forecast 10% POE (MVA)					Firm Capacity Summer (MVA)	Historical		Forecast 10% POE (MVA)				
				2025 PF	2025 Load (MVA)	2026	2027	2028	2029	2030		24/25 PF	24/25 Load (MVA)	25/26	26/27	27/28	28/29	29/30
LDL	Lilydale	99	96.9	1.00	47.3	56.2	57.5	58.4	60.4	63.7	90.1	0.99	63.4	71.7	72.4	72.6	72.7	73.9
LGA	Leongatha	73	44.3	1.00	30.6	38.8	40.4	42.1	44	47.9	44.2	1.00	30.2	34	34.4	35.1	34.9	35.4
LLG	Lang-Lang	33	0	1.00	20.3	30.7	31	31.3	31.6	32.6	0	0.99	22.5	28.7	33.1	33	33.1	33.2
LYD	Lysterfield	33	0	1.00	15.8	15.8	16.1	16.2	16.3	16.5	0	1.00	20.3	24	24.2	24.1	24.1	24.2
MBY	Mt Beauty	30	21.4	0.99	8.2	9.6	9.8	10	10.3	10.8	19.9	0.83	4	5.2	5.3	5.3	5.3	5.4
MDI	Murrindindi	0.5	0	0.89	0.2	0.2	0.2	0.2	0.2	0.2	0	0.87	0.2	0.2	0.2	0.2	0.2	0.2
MFA	Maffra	40.5	37.8	1.00	25.1	30.2	31	32.1	33.5	36.5	31.1	1.00	28.7	31.1	32.1	32.1	32.3	32.6
MJG	Merrijig	20	0	0.97	14.2	17.1	17.9	18.8	18.7	21.6	0	0.99	1.9	3.6	3.7	3.8	3.7	3.8
MOE	Moe	40.5	36.3	1.00	30.1	32.6	35.2	34.7	34.9	37.7	33.2	1.00	35.3	38.7	38.9	40.9	41.1	41.2
MSD	Mansfield	26	19.2	1.00	16.2	20.1	20.6	21.1	21.9	23.3	18.1	1.00	15.8	20.3	20.3	20.3	20.3	20.3
MWL	Morwell Zone Substation	66	49.5	1.00	33.2	36.6	37.1	37.6	38.3	40.5	49.5	1.00	31.5	40.8	40.9	40.8	40.8	41
MYT	Myrtleford	20	12.9	1.00	14.9	18.9	19.5	20.1	20.8	22.4	13.4	1.00	14	16.7	16.8	16.7	16.8	16.9
NLA	Newmerella	10	7.5	0.99	7.3	9.3	9.5	9.7	9.9	10.4	7.5	0.97	7	8.3	8.4	8.5	8.5	8.6
NRN	Narre Warren	33	0	1.00	16.7	18.3	18.5	18.7	18.9	19.3	0	0.99	21.8	25.6	25.7	25.5	25.6	25.7

			Winter								Summer							
			Historical		Forecast 10% POE (MVA)					Historical		Forecast 10% POE (MVA)						
ZSS	Name	Name Plate Rating (MVA)	Firm Capacity Winter (MVA)	2025 PF	2025 Load (MVA)	2026	2027	2028	2029	2030	Firm Capacity Summer (MVA)	24/25 PF	24/25 Load (MVA)	25/26	26/27	27/28	28/29	29/30
OFR	Officer	66	48	0.99	47.5	66.6	72.8	76.1	78.7	81.2	45.2	1.00	62.2	69.6	76.6	81.6	84.5	86.9
PHI	Phillip Island	26	16.3	0.99	20.3	23.6	23.8	23.9	24.3	24.8	14.6	0.96	21.3	27.6	28.1	28.1	28	28.2
PHM	Pakenham	66	49.1	1.00	46.5	71.8	72.5	72.9	73.9	76.2	45	1.00	50.4	75.5	79.9	79.6	79.6	80
RUBA	Rubicon A	40	30.2	0.99	11.2	14.7	14.9	15.1	15.2	15.6	30	1.00	10.2	13.2	13.1	13	13	13
RVE	Rowville	33	0	1.00	16.8	18.2	18.4	18.4	18.5	18.9	0	0.91	29.1	30.8	30.6	30.3	30.1	30
RWN	Ringwood Nth	66	45.2	1.00	32.1	34.5	34.7	35.1	35.2	35.9	41	1.00	43.5	50.2	50.4	49.9	49.9	49.9
RWT	Ringwood	150	95	1.00	66.3	88.6	89.6	90.6	91.8	94.5	95	1.00	94.3	104	103.9	103.5	103.9	104.4
SLE	Sale	60	38.7	0.96	27.8	34.4	34.6	34.6	35.8	36.7	39.7	1.00	28.4	37.7	41.6	41.3	41.5	41.2
SMG	South Morang	66	49.1	1.00	30.8	36.2	36.4	46.2	46.1	46.7	45	1.00	43.2	51.2	51.4	51.1	60.9	60.8
SMR	Seymour	66	29.8	1.00	33.6	36.2	36.3	36.9	38.2	40.2	25.4	1.00	34.9	41.6	41.7	41.5	41.4	41.7
TGN	Traralgon	60	36.7	0.97	37.9	44.3	48.3	48.8	50	49.9	36.2	0.99	42.7	49.2	49.3	52.5	52.4	52.7
TT	Thomastown	84	68.4	0.99	68.3	78.1	79.5	83.2	86.8	94.3	58.6	1.00	75.2	82.1	82.8	82.7	83.1	84.7
WGI	Wonthaggi	40.5	36.1	1.00	35.4	47.7	49.1	49	49.3	50.5	35.3	0.99	38.7	54.5	54.6	54.5	54.5	54.7
WGL	Warragul	84	70.5	0.99	62.5	75.1	78.8	84.5	85.7	88.6	61.9	0.99	70.3	83.6	87.3	89.4	94.8	95.1

			Winter								Summer							
			Historical		Forecast 10% POE (MVA)					Historical		Forecast 10% POE (MVA)						
ZSS	Name	Name Plate Rating (MVA)	Firm Capacity Winter (MVA)	2025 PF	2025 Load (MVA)	2026	2027	2028	2029	2030	Firm Capacity Summer (MVA)	24/25 PF	24/25 Load (MVA)	25/26	26/27	27/28	28/29	29/30
WN	Wangaratta	66	43.4	1.00	40.4	45	45.9	46.1	47	51.8	37.2	0.99	47.9	57.1	57.7	57.4	58.2	57.8
WO	Wodonga	99	81.5	1.00	40.8	44.5	45.2	46.2	47.3	48.8	74.9	0.99	43.1	50.1	50.2	50.4	50.7	51.3
WOTS	Wodonga Zone Sub	70.4	50.5	1.00	34	41.3	42.7	44.5	46.2	50.3	44	1.00	36.9	41.4	41.9	42.6	42.5	43.1
WT	Watsonia	109	83.7	1.00	54.6	55.6	56.1	57.1	57.7	59.6	81.6	0.99	65.3	74.7	74.8	74.5	74.3	75.1
WYK	Woori Yallock	66	48.2	1.00	25.9	31.8	32.3	33.1	34	35.6	46.2	1.00	31.4	34.6	34.7	34.3	34.1	34.1

## E.5. Minimum demand forecasts for zone substations

Table 36: Minimum Demand Forecast for zone substations

Zone Substation	N' Export Rating (MW)	N-1' Export Rating (MW)	Minimum Demand (MW)							
			Actual		10% POE					
			PF	2025	2026	2027	2028	2029	2030	95% Hours
BDL	-5.81	-3.32	0.88	-7.8	-15.5	-16.6	-17.5	-17.9	-18.9	12.75
BGE	-6.98	-3.81	0.91	-5.8	-7.5	-8.1	-8.7	-8.7	-9.3	25.25
BN	-1.21	-1.21	1	-5.3	-5.6	-6.2	-6.9	-7.4	-7.8	10.00
BRA	-7.02	-4.71	0.82	-1.8	-6.2	-6.9	-8.2	-8.2	-8.5	20.75
BRT	0.00	0.00	0.68	-1.4	-3.2	-3.5	-3.7	-4	-4	84.50
BWA	-2.17	0.00	0.96	-5	-6.4	-6.5	-6.6	-6.7	-6.7	8.50
BWN	0.00	0.00	0.99	0	-3.7	-4.3	-4.8	-5.2	-5.4	76.25
BWR	-9.03	-5.81	0.91	-5.2	-10.9	-11.8	-12.8	-13.1	-13.4	43.25
CF	0.00	0.00	0.94	0.1	-0.3	-0.3	-0.3	-0.3	-0.3	2.00
CLN	-50.81	-27.90	0.99	-53.5	-68.7	-77.5	-84.4	-89.8	-94.5	73.00
CNR	-0.45	0.00	0.92	-0.6	-1	-1.1	-1.2	-1.3	-1.3	29.50
CPK	-10.00	-5.29	0.97	-3.8	-9.9	-10.8	-11.9	-12.8	-13.2	89.25
CRE	-12.80	-6.72	0.98	-12.8	-11	-13.7	-9.7	-11.3	-12.1	18.75

# AusNet

CYN	-13.50	-9.13	0.99	-4.9	-7	-7.9	-8.8	-9.3	-9.6	15.75
DRN	-20.21	-9.95	1	-24.5	-34.7	-37.2	-39.1	-40.1	-42	51.50
ELM	-16.13	-11.39	1	-7.4	-15.1	-16.9	-18.4	-20	-20	61.25
EPG	-3.57	-2.43	0	0.1	-16.4	-19.4	-21.5	-23	-23.8	142.25
FGY	0.00	0.00	0.98	-4.4	-10.3	-11.5	-12	-12.8	-12.9	21.00
FTR	0.00	0.00	0.94	-3.2	-5	-4.5	-5	-4.9	-5.1	0.75
HPK	-29.70	-19.40	1	-29.7	-34.3	-37	-38.9	-39.8	-40.9	46.50
KLK	-0.11	-0.03	1	-1.2	-2.3	-2.6	-2.7	-2.8	-2.9	0.25
KLO	-31.61	-19.29	0.99	-33.7	-40.7	-47.7	-46.2	-52.3	-56.5	27.75
KMS	0.00	0.00	0.98	-5.6	-5.2	-5.4	-5.4	-5.5	-5.7	1.50
LDL	-4.71	-3.22	0.95	0.1	-6	-7	-7.7	-8.1	-8	95.75
LGA	0.00	0.00	0.76	0.2	-4.6	-5.3	-5.9	-5.8	-6	14.75
LLG	0.00	0.00	0.56	-2	-0.5	-1.1	-1.2	-1.5	-1.7	0.00
LYD	-4.80	0.00	1	-4.8	-8.8	-9.5	-9.8	-10.2	-10.5	33.25
MBY	-0.76	-0.41	0.9	-2.1	-2.7	-2.8	-2.9	-3	-3.1	125.00
MDI	0.00	0.00	0	0	0	0	0	0	0	628.00
MFA	0.00	0.00	1	-2.7	-4.7	-5.3	-5.5	-5.5	-5.8	12.25
MJG	0.00	0.00	0.92	0.3	-0.2	-0.2	-0.2	-0.2	-0.2	2417.25
MOE	-3.86	-2.58	0.82	-8	-15.1	-13.9	-14.6	-14.6	-15	10.25
MSD	0.00	0.00	1	-4.4	-6.2	-7	-7.4	-7.9	-8	76.50
MWL	0.00	0.00	0.83	-0.9	-4	-4.8	-5.4	-5.9	-6	12.25
MYT	-1.09	-0.71	0.97	-3.4	-6.4	-6.7	-7.2	-7.3	-7.6	25.50

# AusNet

NLA	-0.68	-0.46	0.98	-1.9	-3.1	-3.3	-3.6	-3.6	-3.7	51.25
NRN	-3.25	0.00	1	0	-2	-2.3	-2.4	-2.4	-2.7	187.75
OFR	-15.89	-9.76	0.97	-14.8	-18.8	-17.4	-18.2	-18.5	-20.2	28.00
PHI	-2.96	-2.96	0.98	-7.4	-9.3	-10.2	-10.8	-11.1	-11.2	2.00
PHM	-11.28	-6.48	0.97	-6.6	9.8	8.7	8.1	7.2	6.9	9.50
RUBA	-0.21	-0.07	1	-4.2	-6.3	-6.5	-6.7	-7	-7.1	28.75
RVE	-2.91	0.00	0.95	-4.8	-8	-8.7	-9.2	-9.5	-10	56.00
RWN	-12.49	-6.16	1	-5.4	-9.8	-11.1	-11.7	-12.4	-12.9	84.00
RWT	0.00	0.00	1	2.7	0.8	0.5	0.4	0.1	0.6	7.75
SLE	-6.51	-3.61	0.95	-1.6	0.4	-0.2	-0.6	-0.7	-0.7	0.50
SMG	-2.79	-1.44	0.9	-0.4	-4.2	-4.9	-0.4	-0.6	-1	1.00
SMR	0.00	0.00	0	-0.1	-4.9	-5.7	-6.2	-6.5	-6.3	23.25
TGN	-8.14	-4.04	0.99	-10.9	-10.9	-9.6	-10.5	-11.5	-11.8	1.00
TT	0.00	0.00	0.2	0.2	-7.1	-7.9	-8.1	-8.3	-8.3	18.75
WGI	-6.61	-6.61	1	-22	-27.5	-29.2	-30.6	-31.4	-31.9	3.25
WGL	-1.64	-1.22	0.95	-5.4	-4.9	-4.2	0.8	-1	-1.2	24.00
WN	-6.75	-6.75	1	-11	-19.1	-20.5	-21.6	-23	-22.9	35.75
WO	0.00	0.00	0	0	-3.7	-4.6	-5.1	-5.4	-5.9	155.00
WOTS	0.00	0.00	0.7	-9.6	-14.5	-16.2	-17.5	-18.5	-19.1	11.50
WT	0.00	0.00	0.97	1.4	-4.4	-5.7	-5.4	-6.1	-6	25.75
WYK	-4.70	-2.50	0.92	-4.7	-7.4	-8.5	-9.4	-9.3	-10.2	68.25

			Winter			Summer				
ZSS	Name	Name Plate Rating (MVA)	Firm Capacity Winter (MVA)	Load Transfer Capacity (MVA)	Embedded Generation Capacity (MVA)	Estimated Hours at 95% of Peak Load	Firm Capacity Summer (MVA)	Load Transfer Capacity (MVA)	Embedded Generation Capacity (MVA)	Estimated Hours at 95% of Peak Load
BDL	Bairnsdale	81	95.2	0	0	1.5	88	0	0	2.3
BGE	Belgrave	66	47.3	16.4	3.8	2.4	40.4	16.4	3.8	3.4
BN	Benalla	40.5	36.8	1.6	0.15	3.6	30.7	1.6	0.15	12.9
BRA	Boronia	99	86.1	26.5	2	17.5	77.8	26.5	2	80.9
BRT	Bright	40	30	2	0	1.5	27.9	2	0	6.1
BWA	Barnawatha	33	0	0	5	30.6	0	0	5	6.4
BWN	Berwick North	33	0	30.1	0	12.8	0	30.1	0	69.2
BWR	Bayswater	81	79.9	24	0	1.8	66.8	24	0	1.5
CF	Clover Flat	10	7.3	0	0	6.8	6.7	0	0	1.9
CLN	Clyde North	66	97.8	0	0	2.4	89.2	0	0	4.5
CNR	Cann River	10	0	3	2	0.0	0	3	2	0.0
CPK	Chirnside Park	66	48.6	23	1.3	5.3	48.8	23	1.3	3.4
CRE	Cranbourne	66	46.3	21.8	0	3.9	41.1	21.8	0	3.8
CYN	Croydon	99	94	34.8	0	15.5	83	34.8	0	3.8

# AusNet

DRN	Doreen	66	49.1	8	8.8	21.7	49.5	8	8.8	2.6
ELM	Eltham	99	89.1	3.3	0	7.1	80.7	3.3	0	6.8
EPG	Epping	99	98.1	14.1	0	15.5	87.8	14.1	0	4.2
FGY	Ferntree Gully	93	88.4	20.2	0	5.3	81.6	20.2	0	6.4
FTR	Foster	66	49	3	0	8.9	49.1	3	0	2.6
HPK	Hampton Park	99	90.7	14.1	8.8	0.0	81.6	14.1	8.8	1.9
KLK	Kinglake	10	7.4	1	0	13.1	7.4	1	0	7.9
KLO	Kalkallo	66	49.1	0	12	8.3	49.1	0	12	2.3
KMS	Kilmore South	30	30	0	0	5.9	30.3	0	0	1.9
LDL	Lilydale	99	96.9	17.7	2.3	3.6	90.1	17.7	2.3	4.9
LGA	Leongatha	73	44.3	3	1.76	6.5	44.2	3	1.76	2.6
LLG	Lang Lang	33	0	0	0	4.2	0	0	0	4.2
LYD	Lysterfield	33	0	24.6	0.2	4.8	0	24.6	0.2	3.8
MBY	Mt Beauty	30	21.4	3.5	0	5.9	19.9	3.5	0	6.1
MDI	Murrindindi	0.5	0	0.1	0	3.9	0	0.1	0	1.1
MFA	Maffra	40	38.2	6.5	3.8	5.6	31.4	6.5	3.8	1.1

# AusNet

MJG	Merrijig	20	0	9	0	2.1	0	9	0	1.1
MOE	Moe	40.5	36.5	0	10.8	2.4	33.3	0	10.8	6.1
MSD	Mansfield	26	19.2	0	0	8.6	18.1	0	0	2.3
MWL	Morwell	66	49.5	8	1.5	3.9	49.5	8	1.5	3.0
MYT	Myrtleford	20	12.9	0	0	4.8	13.4	0	0	6.1
NLA	Newmerella	10	7.5	3.2	0	0.9	7.5	3.2	0	1.1
NRN	Narre Warren	33	0	29.8	0	1.8	0	29.8	0	6.4
OFR	Officer	66	48	0	0	7.7	45.2	0	0	3.4
PHI	Phillip Island	26	16.3	6	5	5.1	14.6	6	5	0.8
PHM	Pakenham	66	49.1	1.7	0	17.5	45	1.7	0	6.1
RUBA	Rubicon 'A'	40	30.2	0.5	19.9	14.3	30	0.5	19.9	4.2
RVE	Rowville	33	0	5.6	0	7.4	0	5.6	0	2.6
RWN	Ringwood North	66	45.2	1	0	6.2	41	1	0	3.4
RWT	Ringwood Terminal	150	95	16.3	0	3.0	95	16.3	0	4.9
SLE	Sale	60	38.7	0	0	3.0	39.7	0	0	3.0
SMG	South Morang	66	49.1	13.14	1.5	8.9	45	13.14	1.5	4.9

# AusNet

SMR	Seymour	66	32.5	0	0	5.9	28	0	0	1.9
TGN	Traralgon	60	49.2	9.7	10	3.0	48.7	9.7	10	6.4
TT	Thomastown	84	68.4	20.7	6.9	13.7	58.6	20.7	6.9	1.1
WGI	Wonthaggi	40.5	36.1	0	12	1.5	35.3	0	12	0.4
WGL	Warragul	84	74.7	3.2	0	11.0	75.6	3.2	0	6.4
WN	Wangaratta	66	43.4	2.3	2.25	5.3	37.2	2.3	2.25	8.3
WO	Wodonga	99	81.5	3.5	2	7.7	74.9	3.5	2	1.9
WOTS	Wodonga Terminal	70.4	38.9	0	10.2	8.0	38.2	0	10.2	6.8
WT	Watsonia	109	103.8	20.6	0	7.1	101	20.6	0	5.3
WYK	Woori Yallock	66	48.2	0	0.9	1.5	46.2	0	0.9	3.0

## E.6. Additional import-related Information for zone substations

Table 37: Additional Import-Related Information – Winter and Summer

ZSS	Name	Name Plate Rating (MVA)	Winter				Summer			
			Firm Capacity Winter (MVA)	Load Transfer Capacity (MVA)	Embedded Generation Capacity (MVA)	Estimated Hours at 95% of Peak Load	Firm Capacity Summer (MVA)	Load Transfer Capacity (MVA)	Embedded Generation Capacity (MVA)	Estimated Hours at 95% of Peak Load
BDL	Bairnsdale	81	95.2	0	0	1.5	88	0	0	2.3
BGE	Belgrave	66	47.3	16.4	3.8	2.4	40.4	16.4	3.8	3.4
BN	Benalla	40.5	36.8	1.6	0.15	3.6	30.7	1.6	0.15	12.9
BRA	Boronia	99	86.1	26.5	2	17.5	77.8	26.5	2	80.9
BRT	Bright	40	30	2	0	1.5	27.9	2	0	6.1
BWA	Barnawatha	33	0	0	5	30.6	0	0	5	6.4
BWN	Berwick North	33	0	30.1	0	12.8	0	30.1	0	69.2
BWR	Bayswater	81	79.9	24	0	1.8	66.8	24	0	1.5
CF	Clover Flat	10	7.3	0	0	6.8	6.7	0	0	1.9
CLN	Clyde North	99	97.8	0	0	2.4	89.2	0	0	4.5

# AusNet

CNR	Cann River	10	0	3	2	0.0	0	3	2	0.0
CPK	Chirnside Park	66	48.6	23	1.3	5.3	48.8	23	1.3	3.4
CRE	Cranbourne	66	46.3	21.8	0	3.9	41.1	21.8	0	3.8
CYN	Croydon	99	94	34.8	0	15.5	83	34.8	0	3.8
DRN	Doreen	66	49.1	8	8.8	21.7	49.5	8	8.8	2.6
ELM	Eltham	99	89.1	3.3	0	7.1	80.7	3.3	0	6.8
EPG	Epping	99	98.1	14.1	0	15.5	87.8	14.1	0	4.2
FGY	Ferntree Gully	93	88.4	20.2	0	5.3	81.6	20.2	0	6.4
FTR	Foster	66	49	3	0	8.9	49.1	3	0	2.6
HPK	Hampton Park	99	90.7	14.1	8.8	0.0	81.6	14.1	8.8	1.9
KLK	Kinglake	10	7.4	1	0	13.1	7.4	1	0	7.9
KLO	Kalkallo	66	49.1	0	12	8.3	49.1	0	12	2.3
KMS	Kilmore South	30	30	0	0	5.9	30.3	0	0	1.9
LDL	Lilydale	99	96.9	17.7	2.3	3.6	90.1	17.7	2.3	4.9
LGA	Leongatha	73	44.3	3	1.76	6.5	44.2	3	1.76	2.6
LLG	Lang Lang	33	0	0	0	4.2	0	0	0	4.2

# AusNet

LYD	Lysterfield	33	0	24.6	0.2	4.8	0	24.6	0.2	3.8
MBY	Mt Beauty	30	21.4	3.5	0	5.9	19.9	3.5	0	6.1
MDI	Murrindindi	0.5	0	0.1	0	3.9	0	0.1	0	1.1
MFA	Maffra	40	38.2	6.5	3.8	5.6	31.4	6.5	3.8	1.1
MJG	Merrijig	20	0	9	0	2.1	0	9	0	1.1
MOE	Moe	40.5	36.5	0	10.8	2.4	33.3	0	10.8	6.1
MSD	Mansfield	26	19.2	0	0	8.6	18.1	0	0	2.3
MWL	Morwell	66	49.5	8	1.5	3.9	49.5	8	1.5	3.0
MYT	Myrtleford	20	12.9	0	0	4.8	13.4	0	0	6.1
NLA	Newmerella	10	7.5	3.2	0	0.9	7.5	3.2	0	1.1
NRN	Narre Warren	33	0	29.8	0	1.8	0	29.8	0	6.4
OFR	Officer	66	48	0	0	7.7	45.2	0	0	3.4
PHI	Phillip Island	26	16.3	6	5	5.1	14.6	6	5	0.8
PHM	Pakenham	66	49.1	1.7	0	17.5	45	1.7	0	6.1
RUBA	Rubicon 'A'	40	30.2	0.5	19.9	14.3	30	0.5	19.9	4.2
RVE	Rowville	33	0	5.6	0	7.4	0	5.6	0	2.6

# AusNet

RWN	Ringwood North	66	45.2	1	0	6.2	41	1	0	3.4
RWT	Ringwood Terminal	150	95	16.3	0	3.0	95	16.3	0	4.9
SLE	Sale	60	38.7	0	0	3.0	39.7	0	0	3.0
SMG	South Morang	66	49.1	13.14	1.5	8.9	45	13.14	1.5	4.9
SMR	Seymour	66	32.5	0	0	5.9	28	0	0	1.9
TGN	Traralgon	60	49.2	9.7	10	3.0	48.7	9.7	10	6.4
TT	Thomastown	84	68.4	20.7	6.9	13.7	58.6	20.7	6.9	1.1
WGI	Wonthaggi	40.5	35.3	0	12	1.5	35.3	0	12	0.4
WGL	Warragul	84	74.7	3.2	0	11.0	75.6	3.2	0	6.4
WN	Wangaratta	66	43.4	2.3	2.25	5.3	37.2	2.3	2.25	8.3
WO	Wodonga	99	81.5	3.5	2	7.7	74.9	3.5	2	1.9
WOTS	Wodonga Terminal	70.4	38.9	0	10.2	8.0	38.2	0	10.2	6.8
WT	Watsonia	109	103.8	20.6	0	7.1	101	20.6	0	5.3
WYK	Woori Yallock	66	48.2	0	0.9	1.5	46.2	0	0.9	3.0

## F. System Strength Locational Factors and Corresponding Nodes

Table 38 provides the system strength locational factor (SSLF) for each system strength connection point for which AusNet is the Network Service Provider and the corresponding system strength node as required by schedule 5.8 (q) of the NER. The SSLFs have been calculated as per the AEMO System Strength Impact Assessment Guidelines<sup>33</sup>. These values are subject to change and may differ to those provided to proponents during the connection process.

**Table 38: System Strength Locational Factors and Corresponding System Strength Nodes**

Zone Substation	Voltage (kV)	System Strength Locational Factor	System Strength Node <sup>34</sup>
<b>BDL</b>	66	1.4932	Hazelwood
<b>BDL</b>	22	1.6863	Hazelwood
<b>BDSS</b>	66	1.4433	Hazelwood
<b>BGE</b>	66	1.1357	Thomastown
<b>BGE</b>	22	1.3815	Thomastown
<b>BN</b>	66	1.1471	Dederang
<b>BN</b>	22	1.4751	Dederang
<b>BRA</b>	66	1.0886	Thomastown
<b>BRA</b>	22	1.2557	Thomastown
<b>BRT</b>	66	1.3338	Dederang
<b>BRT</b>	22	1.6686	Dederang
<b>BWA</b>	66	1.3265	Dederang
<b>BWA</b>	22	1.8379	Dederang
<b>BWN</b>	66	1.1415	Thomastown
<b>BWN</b>	22	1.6527	Thomastown
<b>BWR</b>	66	1.0767	Thomastown
<b>BWR</b>	22	1.2286	Thomastown
<b>CF</b>	66	1.3101	Dederang
<b>CF</b>	22	1.9786	Dederang
<b>CLN</b>	66	1.0716	Thomastown
<b>CLN</b>	22	1.3144	Thomastown
<b>CNR</b>	66	3.1304	Hazelwood

<sup>33</sup> [System Strength Impact Assessment Guidelines](#), AEMO, July 2024

<sup>34</sup> [2023 System Strength Report](#), AEMO, December 2023

Zone Substation	Voltage (kV)	System Strength Locational Factor	System Strength Node <sup>34</sup>
CNR	22	3.9928	Hazelwood
CPK	66	1.0973	Thomastown
CPK	22	1.3483	Thomastown
CRE	22	1.3009	Thomastown
CYN	66	1.0900	Thomastown
CYN	22	1.2539	Thomastown
DME	66	1.2361	Dederang
DRN	66	1.0750	Thomastown
DRN	22	1.3220	Thomastown
ELM	66	1.0711	Thomastown
ELM	22	1.2279	Thomastown
EPG	66	1.0712	Thomastown
EPG	22	1.2371	Thomastown
FGY	66	1.1255	Thomastown
FGY	22	1.2865	Thomastown
FTR	66	1.3044	Hazelwood
FTR	22	1.5470	Hazelwood
HPK	66	1.1037	Thomastown
HPK	22	1.2671	Thomastown
KLK	66	1.1671	Thomastown
KLK	22	1.7142	Thomastown
KLO	66	1.1443	Thomastown
KLO	22	1.3996	Thomastown
KMS	66	1.2452	Thomastown
KMS	22	1.9482	Thomastown
LDL	66	1.1101	Thomastown
LDL	22	1.2769	Thomastown
LGA	66	1.2108	Hazelwood
LGA	22	1.4458	Hazelwood

<b>LLG</b>	66	1.1502	Thomastown
<b>LLG</b>	22	1.8494	Thomastown
<b>LSSS</b>	66	1.3409	Hazelwood

<b>Zone Substation</b>	<b>Voltage (kV)</b>	<b>System Strength Locational Factor</b>	<b>System Strength Node<sup>34</sup></b>
<b>LYD</b>	66	1.1242	Thomastown
<b>LYD</b>	22	1.6239	Thomastown
<b>MBY</b>	66	1.2352	Dederang
<b>MBY</b>	22	1.9505	Dederang
<b>MDI</b>	66	1.2848	Thomastown
<b>MDI</b>	22	1.3351	Thomastown
<b>MFA</b>	66	1.2586	Hazelwood
<b>MFA</b>	22	1.6878	Hazelwood
<b>MJG</b>	66	1.9695	Dederang
<b>MJG</b>	22	2.6003	Dederang
<b>MOE</b>	66	1.1037	Hazelwood
<b>MOE</b>	22	1.4269	Hazelwood
<b>MSD</b>	66	1.7502	Dederang
<b>MSD</b>	22	2.1886	Dederang
<b>MWL</b>	22	1.3696	Hazelwood
<b>MYT</b>	66	1.3801	Dederang
<b>MYT</b>	22	1.8508	Dederang
<b>NLA</b>	66	2.4726	Hazelwood
<b>NLA</b>	22	3.3034	Hazelwood
<b>NRN</b>	66	1.1299	Thomastown
<b>NRN</b>	22	1.6361	Thomastown
<b>OFR</b>	66	1.1462	Thomastown
<b>OFR</b>	22	1.3871	Thomastown
<b>PHI</b>	66	1.7377	Hazelwood
<b>PHI</b>	22	2.2038	Hazelwood
<b>PHM</b>	66	1.1276	Thomastown
<b>PHM</b>	22	1.3736	Thomastown



<b>RUBA</b>	66	1.3674	Thomastown
<b>RUBA</b>	22	1.6944	Thomastown
<b>RVE</b>	22	1.6847	Thomastown
<b>RWN</b>	66	1.0982	Thomastown
<b>RWN</b>	22	1.3050	Thomastown

<b>Zone Substation</b>	<b>Voltage (kV)</b>	<b>System Strength Locational Factor</b>	<b>System Strength Node<sup>34</sup></b>
<b>SLE</b>	66	1.2997	Hazelwood
<b>SLE</b>	22	1.5384	Hazelwood
<b>SLF</b>	66	1.2215	Thomastown
<b>SMG</b>	66	1.0520	Thomastown
<b>SMG</b>	22	1.3566	Thomastown
<b>SMR</b>	66	1.4491	Thomastown
<b>SMR</b>	22	1.6805	Thomastown
<b>TGN</b>	66	1.1239	Hazelwood
<b>TGN</b>	22	1.3635	Hazelwood
<b>TT</b>	66	1.0546	Thomastown
<b>TT</b>	22	1.2820	Thomastown
<b>WGI</b>	66	1.3836	Hazelwood
<b>WGI</b>	22	1.7028	Hazelwood
<b>WGL</b>	66	1.1845	Hazelwood
<b>WGL</b>	22	1.3381	Hazelwood
<b>WN</b>	66	1.1561	Dederang
<b>WN</b>	22	1.4042	Dederang
<b>WO</b>	66	1.1735	Dederang
<b>WO</b>	22	1.3426	Dederang
<b>WOTS22</b>	22	1.2585	Dederang
<b>WT</b>	66	1.0931	Thomastown
<b>WT</b>	22	1.4024	Thomastown
<b>WYK</b>	66	1.2606	Thomastown
<b>WYK</b>	22	1.4348	Thomastown
<b>YEA</b>	66	1.4763	Thomastown

## AusNet Services

Level 31  
2 Southbank Boulevard  
Southbank VIC 3006  
T +613 9695 6000  
F +613 9695 6666  
Locked Bag 14051 Melbourne City Mail Centre Melbourne VIC 8001  
[www.AusNetservices.com.au](http://www.AusNetservices.com.au)

## Follow us on

-  @AusNetServices
-  @AusNetServices
-  @AusNet.Services.Energy

# AusNet